

Write your name here

Surname

Other names

Pearson Edexcel
Level 1 / Level 2
GCSE (9–1)

Centre Number

--	--	--	--	--

Candidate Number

--	--	--	--	--

Mathematics

Paper 3 (Calculator)

Higher Tier

Tuesday 13 June 2017 – Morning

Time: 1 hour 30 minutes

Paper Reference

1MA1/3H

You must have: Ruler graduated in centimetres and millimetres, protractor, pair of compasses, pen, HB pencil, eraser, calculator. Tracing paper may be used.

Total Marks

Instructions

- Use **black** ink or ball-point pen.
- **Fill in the boxes** at the top of this page with your name, centre number and candidate number.
- Answer **all** questions.
- Answer the questions in the spaces provided – *there may be more space than you need.*
- You must **show all your working.**
- Diagrams are **NOT** accurately drawn, unless otherwise indicated.
- **Calculators may be used.**
- If your calculator does not have a π button, take the value of π to be 3.142 unless the question instructs otherwise.



Information

- The total mark for this paper is 80
- The marks for **each** question are shown in brackets – *use this as a guide as to how much time to spend on each question.*

Advice

- Read each question carefully before you start to answer it.
- Keep an eye on the time.
- Try to answer every question.
- Check your answers if you have time at the end.

Turn over ►

P50549A

©2017 Pearson Education Ltd.

6/6/6/6/7/4/



Pearson

Answer ALL questions.

Write your answers in the spaces provided.

You must write down all the stages in your working.

- 1 $\mathcal{E} = \{\text{odd numbers less than 30}\} = \{1, 3, 5, 7, 9, 11, 13, 15, 17, 19, 21, 23, 25, 27, 29\}$
 $A = \{3, 9, 15, 21, 27\}$
 $B = \{5, 15, 25\}$

(a) Complete the Venn diagram to represent this information.

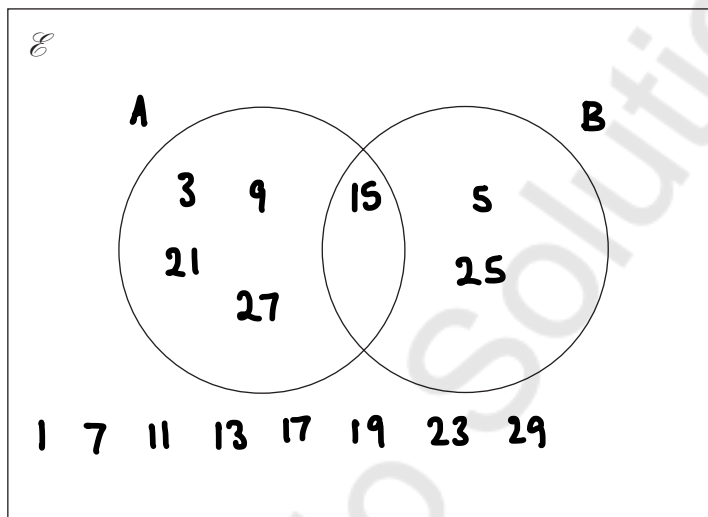

(4)

A number is chosen at random from the universal set, \mathcal{E} .

(b) What is the probability that the number is in the set $A \cup B$?

$\frac{A \cup B}{A \text{ or } B}$

$$P(A \cup B) = \frac{7}{15}$$

$$\frac{7}{15}$$

(2)

(Total for Question 1 is 6 marks)



2 Solve the simultaneous equations

$$\begin{array}{r} 3x + y = -4 \\ 3x - 4y = 6 \\ \hline 5y = -10 \\ \div 5 \qquad \qquad \div 5 \\ y = -2 \end{array}$$

$$\begin{array}{r} 3x + y = -4 \\ 3x + (-2) = -4 \\ 3x - 2 = -4 \\ \quad + 2 \quad + 2 \\ 3x = -2 \\ \div 3 \qquad \qquad \div 3 \\ x = \frac{-2}{3} \end{array}$$

$$x = \frac{-2}{3}$$
$$y = -2$$

(Total for Question 2 is 3 marks)



- 3 The table shows some information about the dress sizes of 25 women.

Dress size	Number of women
8	2
10	9
12	8
14	6



- (a) Find the median dress size.

25

↳ middle value

$$25 \div 2 = 12.5^{\text{th}}$$

12

(1)

3 of the 25 women have a shoe size of 7

Zoe says that if you choose at random one of the 25 women, the probability that she has either a shoe size of 7 or a dress size of 14 is $\frac{9}{25}$ because

$$\frac{3}{25} + \frac{6}{25} = \frac{9}{25}$$

- (b) Is Zoe correct?

You must give a reason for your answer.

No, as a person can be in both categories

(1)

(Total for Question 3 is 2 marks)



DO NOT WRITE IN THIS AREA

DO NOT WRITE IN THIS AREA

DO NOT WRITE IN THIS AREA

4 Daniel bakes 420 cakes.
 He bakes only vanilla cakes, banana cakes, lemon cakes and chocolate cakes.

$\frac{2}{7}$ of the cakes are vanilla cakes.

35% of the cakes are banana cakes.

The ratio of the number of lemon cakes to the number of chocolate cakes is 4:5

Work out the number of lemon cakes Daniel bakes.

Vanilla

$$\frac{2}{7} \times 420 = 120$$

Banana

35% of 420

$$0.35 \times 420 = 147$$

Lemon + Chocolate

$$420 - 120 - 147 = 153$$

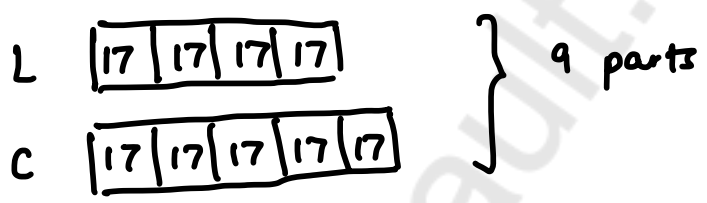

$$153 \div 9 = 17$$

$$\text{Lemon} = 17 \times 4 = 68$$

.....
 68

(Total for Question 4 is 5 marks)

Mathvaudio Solutions



- 5 In the diagram, AB , BC and CD are three sides of a regular polygon P .

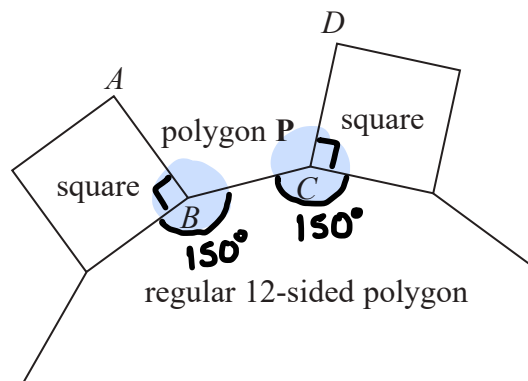

Show that polygon P is a hexagon.
You must show your working.

Square

$$\text{Interior angle} = 90^\circ$$

12-sided polygon

$$\text{Exterior} = \frac{360}{n} = \frac{360}{12} = 30^\circ$$

$$\text{Interior} = 180^\circ - 30^\circ = 150^\circ$$

Polygon P

$$90^\circ + 150^\circ = 240^\circ$$

$$360^\circ - 240^\circ = 120^\circ$$

Hexagon

$$\text{Exterior} = \frac{360}{6} = 60^\circ$$

$$\text{Interior} = 180^\circ - 60^\circ = 120^\circ$$

Interior angle of polygon P = interior angle of a hexagon

(Total for Question 5 is 4 marks)



DO NOT WRITE IN THIS AREA

DO NOT WRITE IN THIS AREA

DO NOT WRITE IN THIS AREA

6 The density of apple juice is 1.05 grams per cm^3 .

The density of fruit syrup is 1.4 grams per cm^3 .

The density of carbonated water is 0.99 grams per cm^3 .

25 cm^3 of apple juice are mixed with 15 cm^3 of fruit syrup and 280 cm^3 of carbonated water to make a drink with a volume of 320 cm^3 .

Work out the density of the drink.

Give your answer correct to 2 decimal places.

$$D = \frac{m}{V}$$

	Apple	Fruit Syrup	Carb. Water	Drink
$D \times V \rightarrow m$	1.05×25 26.25g	1.4×15 21g	0.99×280 277.2g	324.45g
D	1.05 g/ cm^3	1.4 g/ cm^3	0.99 g/ cm^3	$324.45 \div 320$ 1.01390625
V	25 cm^3	15 cm^3	280 cm^3	320 cm^3

$$D = \frac{m}{V}$$

$$1.01390625 \approx 1.01$$

.....1.01.....g/ cm^3

(Total for Question 6 is 4 marks)



7 ABC is a right-angled triangle.

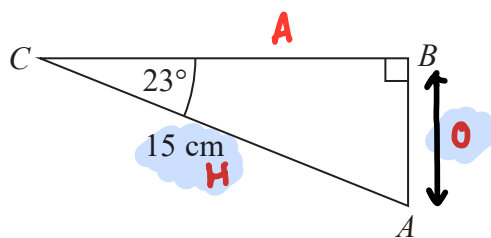

Calculate the length of AB .

Give your answer correct to 3 significant figures.

$$\sin \theta = \frac{O}{H}$$

~~$$\cos \theta = \frac{A}{H}$$~~

~~$$\tan \theta = \frac{O}{A}$$~~

↓

$$\sin(23^\circ) = \frac{AB}{15}$$

x15 x15

$$15 \times \sin(23) = AB$$

$$5.860966927 = AB$$

..... **5.86** cm

(Total for Question 7 is 2 marks)

DO NOT WRITE IN THIS AREA

DO NOT WRITE IN THIS AREA

DO NOT WRITE IN THIS AREA



- 8 A square, with sides of length x cm, is inside a circle.
Each vertex of the square is on the circumference of the circle.

The area of the circle is 49 cm^2 .

Work out the value of x .

Give your answer correct to 3 significant figures.

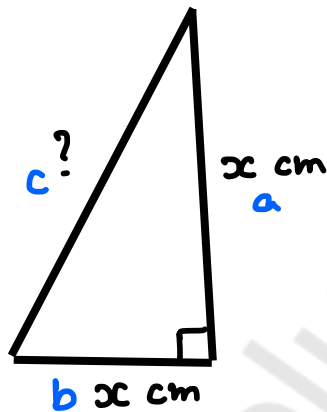
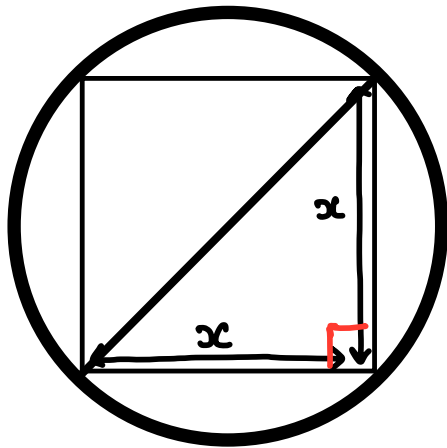

$$\begin{aligned} a^2 + b^2 &= c^2 \\ x^2 + x^2 &= c^2 \\ 2x^2 &= c^2 \\ \sqrt{\quad} \quad \sqrt{\quad} & \\ \sqrt{2x^2} &= c \\ &= \text{diameter} \end{aligned}$$

$$\frac{\sqrt{2x^2}}{2} = \text{radius}$$

$$A = \pi r^2 \quad r = \text{radius}$$

$$49 = \pi \left(\frac{\sqrt{2x^2}}{2} \right)^2$$

$$49 = \pi \left(\frac{2x^2}{4} \right)$$

$$\div \pi \qquad \div \pi$$

$$\frac{49}{\pi} = \frac{2x^2}{4}$$

$$\times 4 \qquad \times 4$$

$$\frac{196}{\pi} = 2x^2$$

$$\frac{196}{\pi} \div 2 = x^2$$

$$\sqrt{\frac{196}{\pi}} \div 2 = 5.585\dots \qquad 5.59$$

(Total for Question 8 is 4 marks)



- 9 The box plot shows information about the distribution of the amounts of money spent by some male students on their holidays.

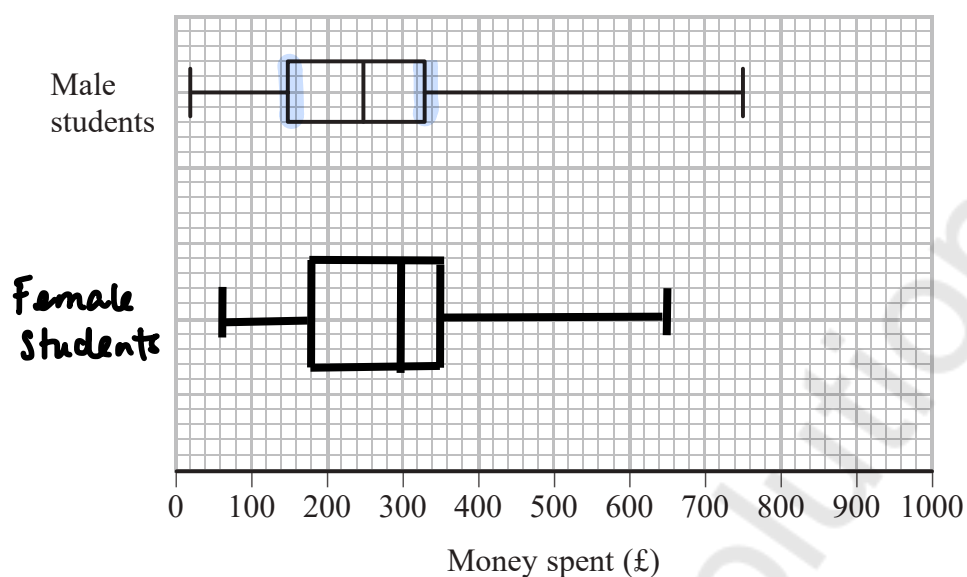

- (a) Work out the interquartile range for the amounts of money spent by these male students.

$$\begin{aligned} \text{IQR} &= \text{UQ} - \text{LQ} \\ &= 330 - 150 \\ &= 180 \end{aligned}$$

£ 180 (2)

The table below shows information about the distribution of the amounts of money spent by some female students on their holidays.

	Smallest	Lower quartile	Median	Upper quartile	Largest
Money spent (£)	60	180	300	350	650

- (b) On the grid above, draw a box plot for the information in the table. (2)



Chris says,

“The box plots show that the female students spent more money than the male students.”

(c) Is Chris correct?

Give a reason for your answer.

Yes. The median for female students is greater than the median for male students.

(1)

(Total for Question 9 is 5 marks)

10 Naoby invests £6000 for 5 years.

The investment gets compound interest of $x\%$ per annum.

At the end of 5 years the investment is worth £8029.35

Work out the value of x .

Final amount = investment \times multiplier $n \leftarrow$ no. of years

$$\text{Multiplier} = \frac{100\% + x\%}{100}$$

$$= \frac{100 + x}{100}$$

$$8029.35 = 6000 \times \left(\frac{100 + x}{100}\right)^5$$

$$\div 6000$$

$$\div 600$$

$$1.338225 = \left(\frac{100 + x}{100}\right)^5$$

$$\sqrt[5]{}$$

$$\sqrt[5]{}$$

$$1.05999908 = \frac{100 + x}{100}$$

$$\times 100 \quad \times 100$$

$$105.9999908 = 100 + x$$

$$- 100 \quad - 100$$

$$5.9999908 = x$$

$$6 = x$$

6

(Total for Question 10 is 3 marks)



- 11 Jeff is choosing a shrub and a rose tree for his garden.
At the garden centre there are 17 different types of shrubs and some rose trees.

Jeff says,

“There are 215 different ways to choose one shrub and one rose tree.”

Could Jeff be correct?

You must show how you get your answer.

$$\begin{array}{r} 17 \times x = 215 \\ \div 17 \qquad \div 17 \\ x = 12.64705\dots \end{array}$$

No. The number of rose trees has to be a whole number.

(Total for Question 11 is 2 marks)

- 12 The points A , B , C and D lie in order on a straight line.

$$\begin{array}{l} AB:BD = 1:5 = 6 \text{ parts} \xrightarrow{\times 3} AB:BD \\ AC:CD = 7:11 = 18 \text{ parts} \qquad \qquad \qquad 3:15 \end{array}$$

Work out $AB:BC:CD$

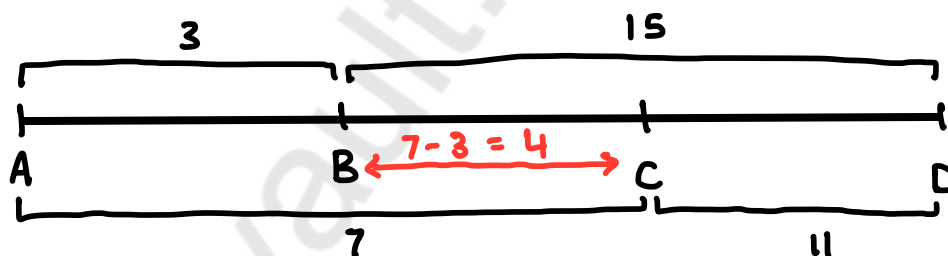

$$AB = 3 \qquad BC = 4 \qquad CD = 11$$

$$3:4:11$$

$$\dots\dots\dots 3 : 4 : 11 \dots\dots\dots$$

(Total for Question 12 is 3 marks)



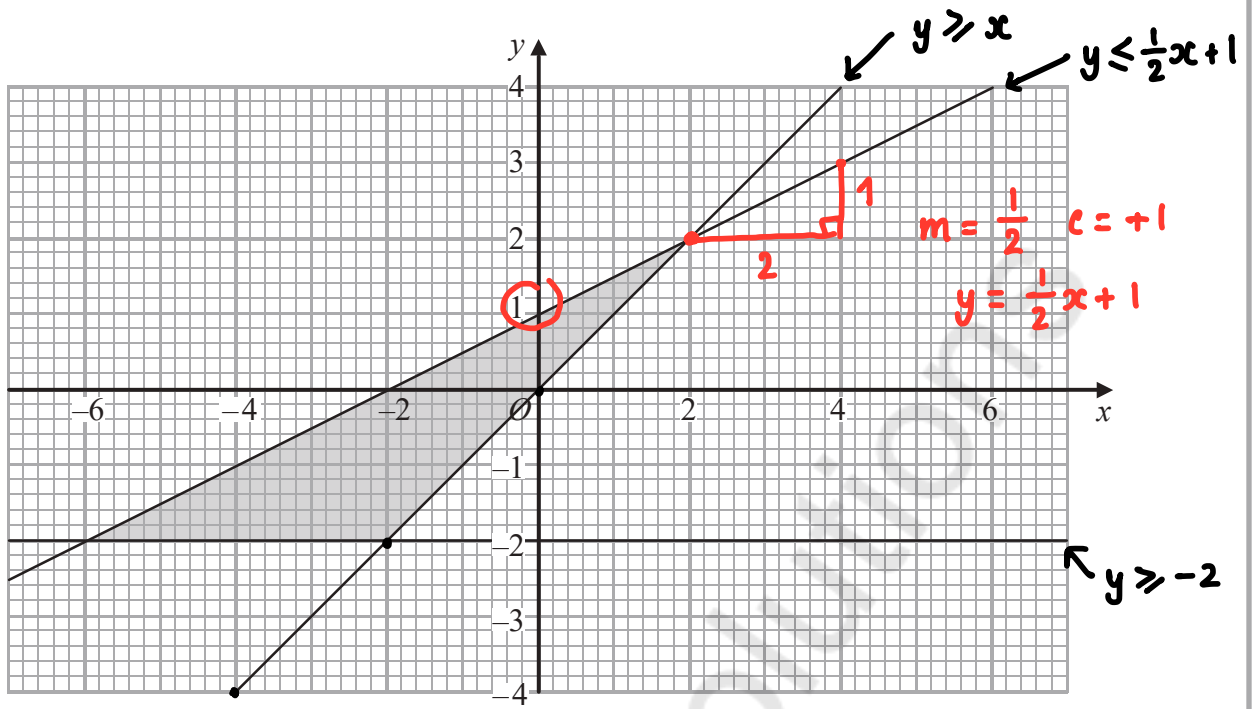

Write down the three inequalities that define the shaded region.

_____ \leq \geq
 - - - - - $<$ $>$

$y \geq x$
 $y \leq \frac{1}{2}x + 1$
 $y \geq -2$

(Total for Question 13 is 4 marks)

DO NOT WRITE IN THIS AREA

DO NOT WRITE IN THIS AREA

DO NOT WRITE IN THIS AREA



14 (a) Simplify $\frac{x^2 - 16}{2x^2 - 5x - 12}$

$$x^2 - 16 \rightarrow (x + 4)(x - 4)$$

(D.O.T.S)

$$\frac{(x+4)\cancel{(x-4)}}{(2x+3)\cancel{(x-4)}} = \frac{x+4}{2x+3}$$

$$2x^2 - 5x - 12$$

$$2 \times 12 = 24$$

$$- \quad x \quad - = 24$$

$$- \quad + \quad - = -5$$

$$2x^2 + 3x - 8x - 12$$

$$x(2x+3) - 4(2x+3)$$

$$(2x+3)(x-4)$$

$$\frac{x+4}{2x+3}$$

(3)

$$\begin{array}{r} 24 \\ \underline{1 \quad 24} \quad 4 \quad 6 \\ 2 \quad 12 \\ \underline{3 \quad -8} \end{array}$$

(b) Make v the subject of the formula $w = \frac{15(t - 2v)}{v}$

$$w = \frac{15(t - 2v)}{v}$$

$$wv = 15(t - 2v)$$

$$wv = 15t - 30v$$

$$+30v \quad +30v$$

$$wv + 30v = 15t$$

$$v(w + 30) = 15t$$

$$\div (w + 30) \quad \div (w + 30)$$

$$v = \frac{15t}{w + 30}$$

$$v = \frac{15t}{w + 30}$$

(3)

(Total for Question 14 is 6 marks)



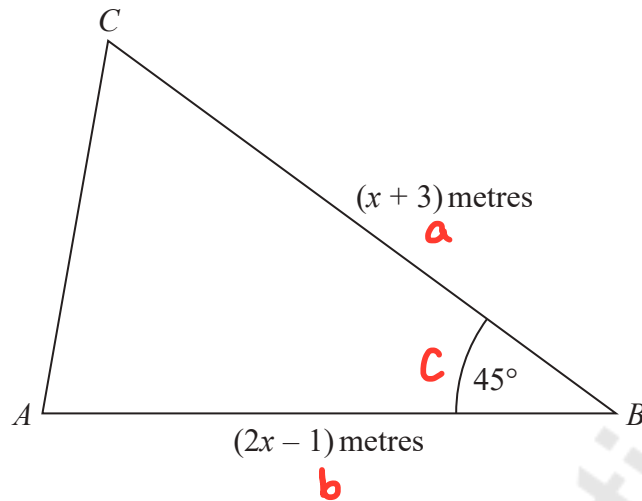

The area of triangle ABC is $6\sqrt{2} \text{ m}^2$.

Calculate the value of x .

Give your answer correct to 3 significant figures.

$$\text{Area} = \frac{1}{2} ab \sin C$$

$$6\sqrt{2} = \frac{1}{2} (x+3)(2x-1) \sin(45)$$

$$6\sqrt{2} = \frac{1}{2} (x+3)(2x-1) \left(\frac{\sqrt{2}}{2}\right)$$

$$\begin{array}{ccc} \times 2 & & \times 2 \\ 12\sqrt{2} & = & (x+3)(2x-1) \left(\frac{\sqrt{2}}{2}\right) \end{array}$$

$$\div \frac{\sqrt{2}}{2}$$

$$24 = (x+3)(2x-1)$$

$$24 = 2x^2 - x + 6x - 3$$

$$\begin{array}{r} 24 = 2x^2 + 5x - 3 \\ -24 \qquad \qquad -24 \\ \hline 0 = 2x^2 + 5x - 27 \end{array}$$

$$a = 2 \quad b = 5 \quad c = -27$$

$$x = \frac{-b \pm \sqrt{b^2 - 4ac}}{2a}$$

$$\div \frac{\sqrt{2}}{2} \rightarrow x = \frac{-(5) \pm \sqrt{(5)^2 - 4(2)(-27)}}{2(2)}$$

$$x = 2.63... \quad x = -5.13...$$

$$x > 0 \quad \therefore x = 2.63...$$

2.63

(Total for Question 15 is 5 marks)



16 Using $x_{n+1} = -2 - \frac{4}{x_n^2}$
with $x_0 = -2.5$

(a) find the values of x_1 , x_2 and x_3

$$x_1 = -2 - \frac{4}{(-2.5)^2} = -2.64$$

$$x_2 = -2 - \frac{4}{(\text{Ans})^2} = -2.573921028$$

$$x_3 = -2 - \frac{4}{(\text{Ans})^2} = -2.603767255$$

$$x_1 = -2.64$$

$$x_2 = -2.573921028$$

$$x_3 = -2.603767255$$

(3)

(b) Explain the relationship between the values of x_1 , x_2 and x_3 and the equation $x^3 + 2x^2 + 4 = 0$

They are estimates to a solution of $x^3 + 2x^2 + 4 = 0$

$x = -2 - \frac{4}{x^2}$ is a rearrangement of $x^3 + 2x^2 + 4 = 0$

(2)

(Total for Question 16 is 5 marks)



DO NOT WRITE IN THIS AREA

DO NOT WRITE IN THIS AREA

DO NOT WRITE IN THIS AREA

17 A train travelled along a track in 110 minutes, correct to the nearest 5 minutes.

Jake finds out that the track is 270 km long.

He assumes that the track has been measured correct to the nearest 10 km.

(a) Could the average speed of the train have been greater than 160 km/h?

You must show how you get your answer.

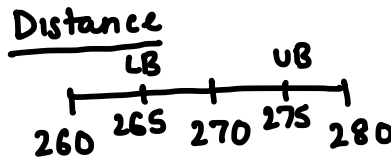
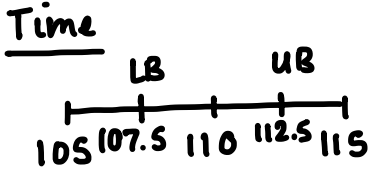

$$S = \frac{D}{T}$$

$$S = \frac{D}{T}$$

$$S_{UB} = \frac{D_{UB}}{T_{LB}}$$

$$D_{UB} = 275$$

$$T_{LB} = 107.5 \text{ mins} \rightarrow \div 60 \rightarrow 1.7916\text{h}$$

$$= \frac{275}{1.7916}$$

$$= 153.4883721$$

No. $153.48... < 160$

(4)

Jake's assumption was wrong.

The track was measured correct to the nearest 5 km.

(b) Explain how this could affect your decision in part (a).

The speed would still be lower than 160 km/h.

(1)

(Total for Question 17 is 5 marks)



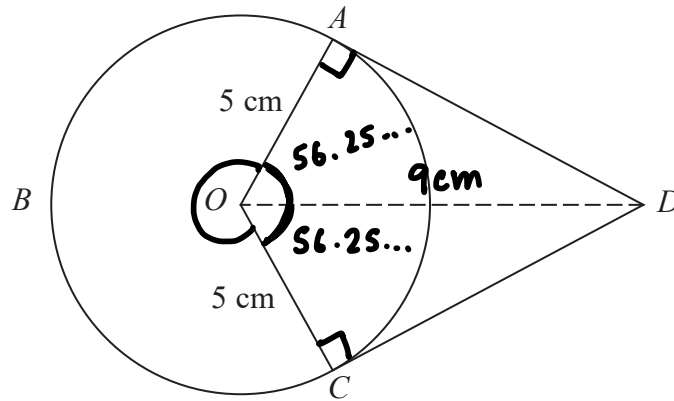

A , B and C are points on a circle of radius 5 cm, centre O .

DA and DC are tangents to the circle.

$DO = 9$ cm

$$\sin \theta = \frac{O}{H} \quad \cos \theta = \frac{A}{H} \quad \tan \theta = \frac{O}{A}$$

Work out the length of arc ABC .

Give your answer correct to 3 significant figures.

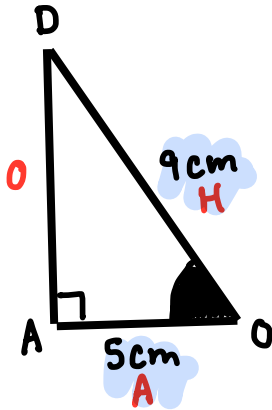

$$\cos \theta = \frac{A}{H}$$

$$\cos \theta = \frac{5}{9}$$

$$\theta = \cos^{-1}\left(\frac{5}{9}\right)$$

$$= 56.2510114$$

$$\text{Angle } AOC = 2 \times 56.2510114$$

$$= 112.5020228$$

$$360 - 112.5020228 = 247.4979772$$

$$\text{Arc length} = \frac{\theta}{360} \times 2\pi r$$

$$= \frac{247.49...}{360} \times 2\pi(5)$$

$$= 21.59827297$$

$$= 21.6 \text{ cm}$$

..... 21.6 cm

(Total for Question 18 is 5 marks)



19 Solve $2x^2 + 3x - 2 > 0$

$$2 \times 2 = 4 \quad _ \times _ = 4$$

$$\frac{4}{2 \quad 2} \quad _ + _ = 3$$

$$\boxed{-1 \quad +4}$$

$$2x^2 - 1x + 4x - 2$$

$$x(2x - 1) + 2(2x - 1)$$

$$(2x - 1)(x + 2) = 0$$

$$2x - 1 = 0 \quad x + 2 = 0$$

$$+1 \quad +1$$

$$-2 \quad -2$$

$$\div 2 \quad \div 2$$

$$x = \frac{1}{2}$$

$$x = -2$$

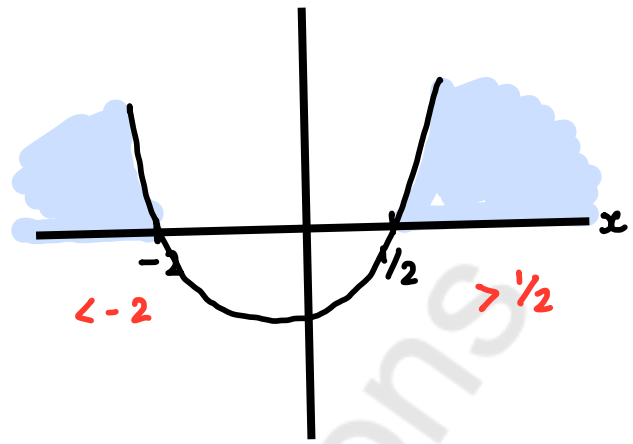

$$x < -2 \quad x > \frac{1}{2}$$

(Total for Question 19 is 3 marks)

DO NOT WRITE IN THIS AREA

DO NOT WRITE IN THIS AREA

DO NOT WRITE IN THIS AREA



20 The equation of a curve is $y = a^x$
A is the point where the curve intersects the y-axis.

(a) State the coordinates of A.

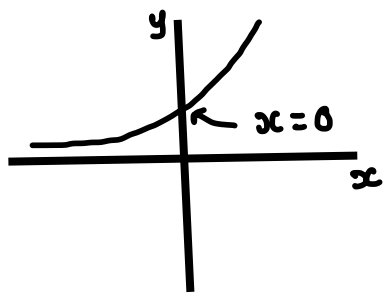

$$y = a^x$$
$$y = a^0$$
$$y = 1$$
$$(x, y)$$
$$(0, 1)$$

(..... 0 , 1)

(1)

The equation of circle C is $x^2 + y^2 = 16$ radius = $\sqrt{16} = 4$ Centre (0, 0)

The circle C is translated by the vector $\begin{pmatrix} 3 \\ 0 \end{pmatrix}$ to give circle B.

(b) Draw a sketch of circle B.

$$\begin{pmatrix} \leftarrow \\ \downarrow \end{pmatrix} \begin{pmatrix} + \\ + \end{pmatrix} \begin{pmatrix} 3 \\ 0 \end{pmatrix} = 3 \text{ right}$$

Label with coordinates
the centre of circle B
and any points of intersection with the x-axis.

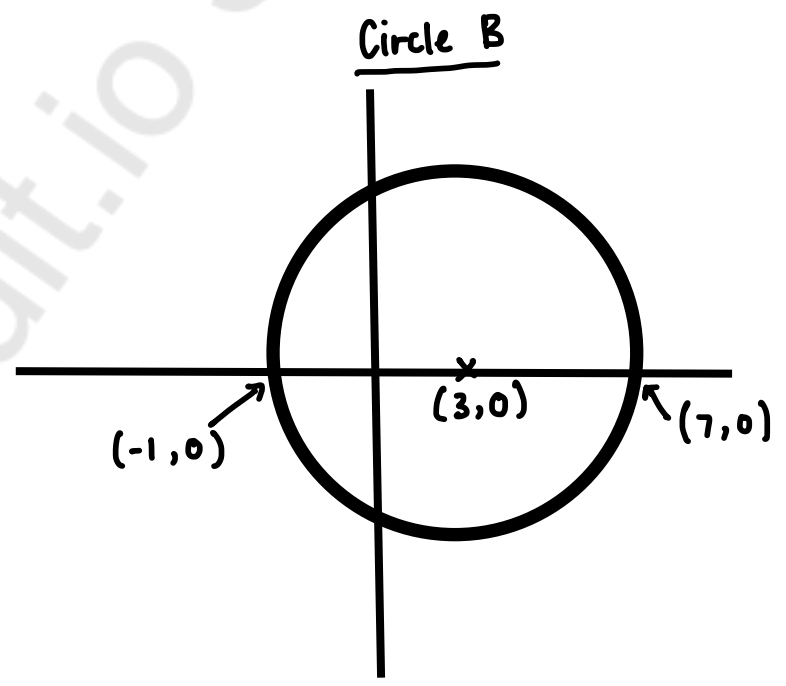
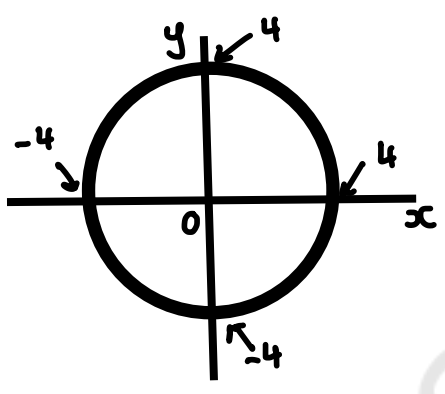

(3)

(Total for Question 20 is 4 marks)

TOTAL FOR PAPER IS 80 MARKS

