

Please check the examination details below before entering your candidate information

Candidate surname

Other names

Centre Number

Candidate Number

**Pearson Edexcel**  
**Level 1/Level 2 GCSE (9–1)**

--	--	--	--	--

--	--	--	--

**Thursday 4 June 2020**

Morning (Time: 1 hour 30 minutes)

Paper Reference **1MA1/2F**

**Mathematics**

**Paper 2 (Calculator)**

**Foundation Tier**

**You must have:** Ruler graduated in centimetres and millimetres, protractor, pair of compasses, pen, HB pencil, eraser, calculator. Tracing paper may be used.

Total Marks

### Instructions

- Use **black** ink or ball-point pen.
- **Fill in the boxes** at the top of this page with your name, centre number and candidate number.
- Answer **all** questions.
- Answer the questions in the spaces provided – *there may be more space than you need.*
- You must **show all your working**.
- Diagrams are **NOT** accurately drawn, unless otherwise indicated.
- **Calculators may be used.**
- If your calculator does not have a  $\pi$  button, take the value of  $\pi$  to be 3.142 unless the question instructs otherwise.



### Information

- The total mark for this paper is 80
- The marks for **each** question are shown in brackets – *use this as a guide as to how much time to spend on each question.*

### Advice

- Read each question carefully before you start to answer it.
- Keep an eye on the time.
- Try to answer every question.
- Check your answers if you have time at the end.

Turn over ►

P62275A

©2020 Pearson Education Ltd.

1/1/1/



  
Pearson

Answer ALL questions.

Write your answers in the spaces provided.

You must write down all the stages in your working.

- 1 Write 0.37 as a fraction.

10ths  
↓  
↑  
100ths

$$\frac{37}{100}$$

$$\frac{37}{100}$$

(Total for Question 1 is 1 mark)

- 2 Write 29381 correct to the nearest 1000

2 9 3 8 1  
ten<sup>th</sup>s. thous. hund. tens ones  
↑

$$\begin{array}{r} 29381 \\ \underline{29000} \quad \downarrow \quad 30000 \\ 29500 \end{array}$$

29000

(Total for Question 2 is 1 mark)

- 3 Simplify  $3e - e + 4e$

$$\underline{3e - 1e} + 4e$$

$$2e + 4e = 6e$$

6e

(Total for Question 3 is 1 mark)

- 4 Write  $\frac{1}{4}$  as a percentage.

$$F \xrightarrow{\times 100} P$$

$$\frac{1}{4} \times 100 = 25$$

25 %

(Total for Question 4 is 1 mark)



5 Here is a list of numbers.

3    4    9    18    27    30    36

From the numbers in the list, write down a cube number.

$$1^3 = 1 \times 1 \times 1 = 1$$

$$2^3 = 2 \times 2 \times 2 = 8$$

$$3^3 = 3 \times 3 \times 3 = 27$$

27

(Total for Question 5 is 1 mark)

6 Liz is watching a film at the cinema.

The film started at 1430

The film is 105 minutes long.

When the film ends, Liz takes 20 minutes to get to the bus stop.

A bus leaves the bus stop at 1645

Does Liz get to the bus stop in time to get this bus?

You must show all your working.

$$60 \text{ mins} = 1 \text{ hour}$$

$$60 \overline{)105}$$

$$105 \text{ mins} = 1 \text{ hour } 45 \text{ minutes}$$

$$\begin{array}{ccccccc}
 14:30 & & 15:30 & & 16:00 & & 16:15 & \leftarrow \text{Film ends} \\
 \underbrace{\hspace{2cm}} & & \underbrace{\hspace{2cm}} & & \underbrace{\hspace{2cm}} & & & \\
 +1\text{h} & & +30\text{mins} & & +15 & & & 
 \end{array}$$

$$\begin{array}{ccc}
 16:15 & & 16:35 \\
 \underbrace{\hspace{2cm}} & & \\
 +20\text{mins} & & 
 \end{array}$$

Yes. She arrives to the bus stop at 16:35.

(Total for Question 6 is 3 marks)



7 Farhad, George and Tom each did a test.

Here are their marks for the test.

Farhad	74
George	77
Tom	72

George drew this bar chart to show the marks they got.  
The bar chart is **not** fully correct.

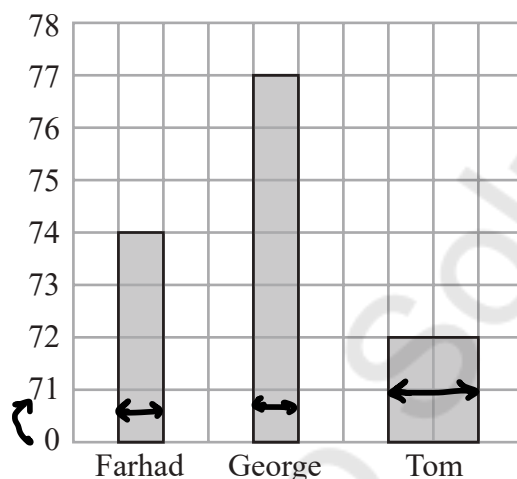

Write down **two** things that are wrong with George's bar chart.

1. *The bars are not the same width*

2. *The marks on the y-axis jump from 0 to 71.*

(Total for Question 7 is 2 marks)



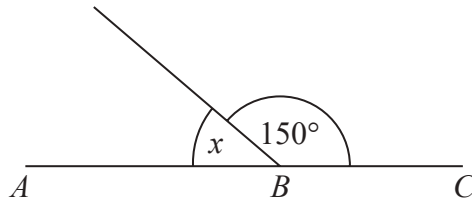

$ABC$  is a straight line.

- (a) (i) Work out the size of the angle marked  $x$ .

$$180 - 150 = 30^\circ$$

30 °

(1)

- (ii) Give a reason for your answer.

Adjacent angles on a straight line sum to  $180^\circ$

(1)

The diagram below is wrong.

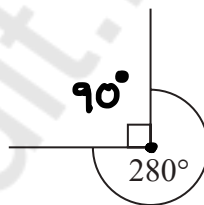

$$280 + 90 = 370^\circ$$

- (b) Explain why.

The angles should sum to  $360^\circ$

(1)

(Total for Question 8 is 3 marks)



- 9 This scale can be used to change between kilometres and miles.

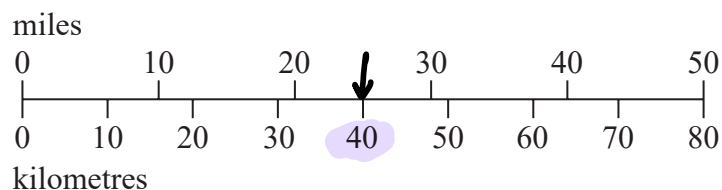

- (a) Use the scale to change 40 kilometres to miles.

..... **25** miles  
(1)

Here is an approximate rule to change from kilometres to miles.

Divide the distance in kilometres by 10 and then multiply by 6

- (b) Use this approximate rule to change 40 kilometres to miles.

$$(40 \div 10) \times 6$$

$$4 \times 6 = 24$$

..... **24** miles  
(2)

- (c) Compare your answer to part (b) with your answer to part (a).

The answer to (b) is less than the answer to (a).

(1)

(Total for Question 9 is 4 marks)



10 (a) Solve  $3m = 36$

$$\begin{array}{r} \div 3 \quad \div 3 \\ m = 12 \end{array}$$

$$m = \underline{12} \quad (1)$$

(b) Solve  $7 - x = 3$

$$7 - 4 = 3$$

$$x = \underline{4} \quad (1)$$

(Total for Question 10 is 2 marks)

11 Here is a cuboid.

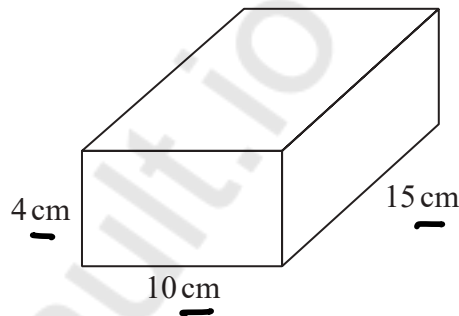

Work out the volume of the cuboid.

$$\begin{aligned} V &= l \times w \times h \\ &= 10 \times 15 \times 4 \\ &= 600 \text{ cm}^3 \end{aligned}$$

$$\underline{600 \text{ cm}^3}$$

(Total for Question 11 is 3 marks)



12 Lucy uses a code to open a lock.

The code is a letter followed by a 2-digit number.

The letter is L or U.

The number is a prime number between 20 and 30 → 23 and 29

Write down all the possibilities for Lucy's code.

$$2 \times 2 = 4 \text{ combinations}$$

L 23      L 29

U 23      U 29

(Total for Question 12 is 2 marks)

13 A machine fills bags with sweets.

There are 4275 sweets.

There are 28 sweets in each full bag.

The machine fills as many bags as possible.

How many sweets are left?

$$4275 \div 28 = 152.6785714$$

152 bags full

$$152 \times 28 = 4256$$

$$4275 - 4256 = 19$$

19

(Total for Question 13 is 3 marks)



DO NOT WRITE IN THIS AREA

DO NOT WRITE IN THIS AREA

DO NOT WRITE IN THIS AREA

14 The table gives information about the number of goals scored by each of three teams.

Team	Number of goals	Angle
City	50 <b>x3</b>	150°
Rovers	45 <b>x3</b>	135°
United	25 <b>x3</b>	75°
<b>Total</b>	<b>120</b>	<b>360°</b>

*Note: A handwritten arrow points from the 'Total' row to the 'Angle' column with the label 'x3'.*

Draw an accurate pie chart for this information.

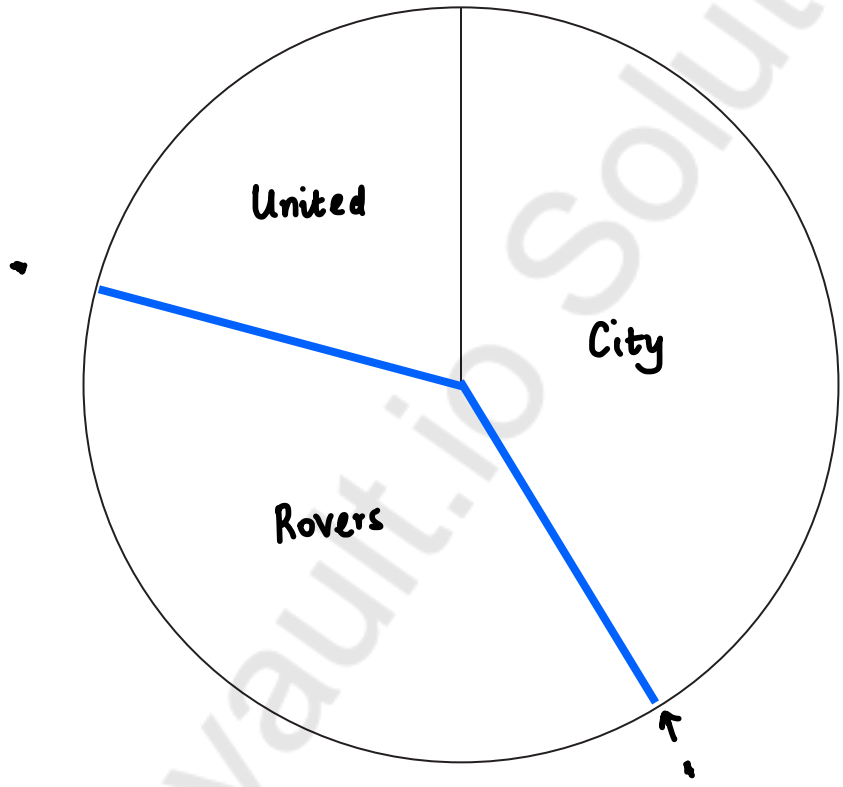

(Total for Question 14 is 3 marks)



15  $T = 3x + 4y$

(a) Work out the value of  $T$  when  $x = 5$  and  $y = -7$

$$\begin{aligned} T &= 3(5) + 4(-7) \\ &= 15 - 28 \\ &= -13 \end{aligned}$$

.....  
-13

(2)

(b) Work out the value of  $y$  when  $T = 38$  and  $x = 6$

$$\begin{aligned} T &= 3x + 4y \\ 38 &= 3(6) + 4y \\ 38 &= 18 + 4y \\ -18 \quad -18 \\ 20 &= 4y \\ \div 4 \quad \quad \quad \div 4 \\ 5 &= y \end{aligned}$$

.....  
5

(2)

(Total for Question 15 is 4 marks)

DO NOT WRITE IN THIS AREA

DO NOT WRITE IN THIS AREA

DO NOT WRITE IN THIS AREA



16 An exam has two papers, Paper 1 and Paper 2

Paper 1 has 60 marks.

Paper 2 has 90 marks.

The pass mark is  $\frac{2}{3}$  of the total number of marks.

Danielle gets 70% of the marks for Paper 1

How many of the marks for Paper 2 must Danielle get in order to get the pass mark?

$$60 + 90 = 150 \text{ marks total}$$

$$\frac{2}{3} \times 150 = 100 \text{ marks (pass marks)}$$

$$70\% \text{ of } 60 = 0.7 \times 60 = 42 \text{ marks paper 1}$$

$$100 - 42 = 58 \text{ marks paper 2}$$

58

(Total for Question 16 is 4 marks)



- 17 Scott wants to make orange juice.  
He is going to buy boxes of oranges.

There are 24 oranges in each box of oranges.

30 oranges make 2 litres of orange juice.

Scott needs to buy enough oranges to make 8 litres of orange juice.

- (a) Work out the number of boxes of oranges that Scott needs to buy.  
You must show all your working.

$$\begin{array}{l} \times 4 \quad \left\{ \begin{array}{l} 30 \text{ oranges} = 2\text{L} \\ 120 \text{ oranges} = 8\text{L} \end{array} \right. \times 4 \end{array}$$

$$120 \div 24 = 5 \text{ boxes}$$

5

(3)

Scott also buys  
1260 apples  
280 bananas

- (b) Write down the ratio of the number of apples that Scott buys to the number of bananas that he buys.  
Give your ratio in its simplest form.

A : B

1260 : 280

$\div 10$   $\div 10$

126 : 28

$\div 2$   $\div 2$

63 : 14

$\div 7$   $\div 7$

9 : 2

9 : 2

(2)

(Total for Question 17 is 5 marks)



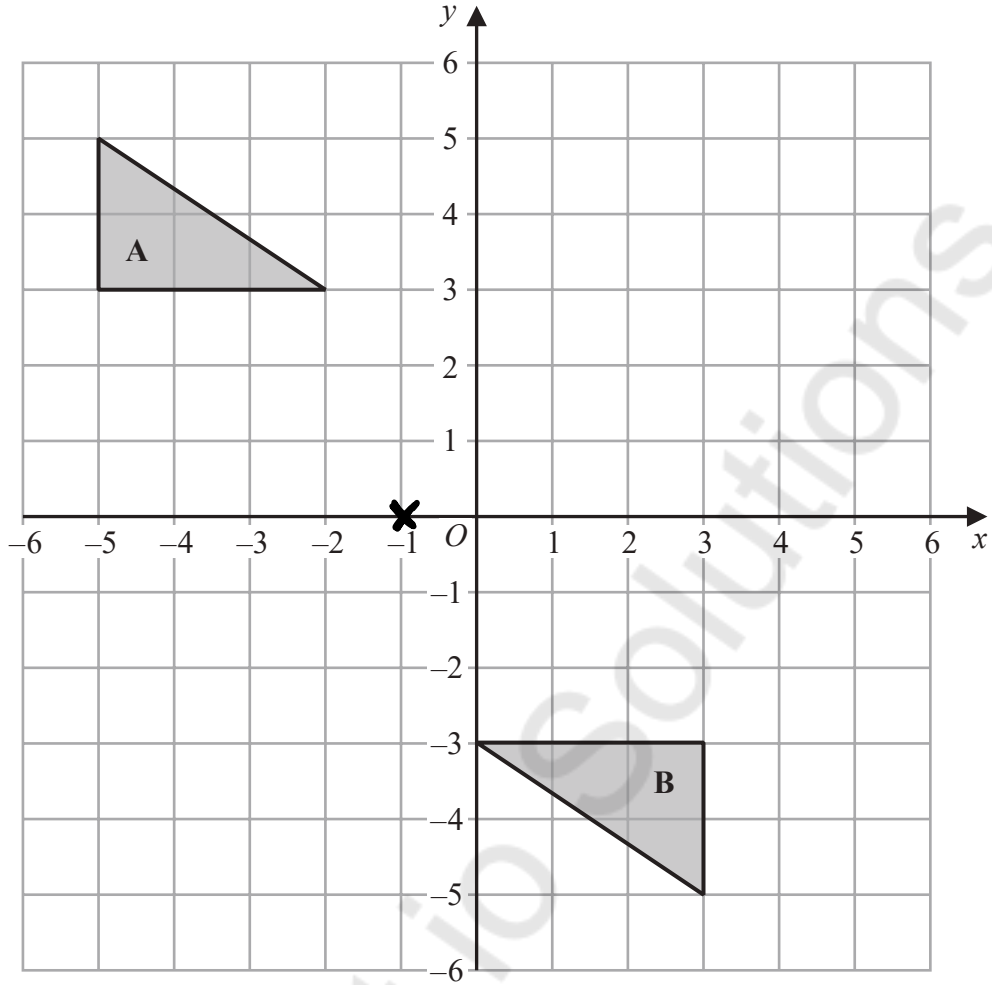

Describe fully the single transformation that maps triangle A onto triangle B.

Rotation  $180^\circ$   $(-1, 0)$

(Total for Question 18 is 2 marks)



19 Adam, Linda and Rytis share an amount of money.

Linda gets three times as much money as Rytis gets.

Linda gets half as much money as Adam gets.

What fraction of the amount of money does Linda get?

$$A = 6 \quad L = 3 \quad R = 1$$

$$\begin{array}{c} \curvearrowright \\ \times 2 \end{array}$$

$$A : L : R$$

$$6 : 3 : 1$$

$$\frac{3}{6+3+1} = \frac{3}{10}$$

$$\frac{3}{10}$$

(Total for Question 19 is 2 marks)

20 Pens and pencils are sold in a shop.

12 pencils cost £1.80

The ratio of the cost of a pen to the cost of a pencil is 7:3

Work out the cost of 5 pens.

$$\div 12 \left( \begin{array}{l} 12 \text{ pencils} = \text{£}1.80 \\ 1 \text{ pencil} = \text{£}0.15 \end{array} \right) \div 12$$

Pen : Pencil

7 : 3

$$\text{Pen } \boxed{0.05} \boxed{\phantom{0.05}} \boxed{\phantom{0.05}} \boxed{\phantom{0.05}} \boxed{\phantom{0.05}} \boxed{\phantom{0.05}} \boxed{\phantom{0.05}} = 0.05 \times 7 = 0.35$$

$$\text{Pencil } \boxed{\phantom{0.05}} \boxed{\phantom{0.05}} \boxed{\phantom{0.05}} = \text{£}0.15$$

$$0.15 \div 3 = 0.05$$

$$\times 5 \left( \begin{array}{l} 1 \text{ pen} = \text{£}0.35 \\ 5 \text{ pens} = \text{£}1.75 \end{array} \right) \times 5$$

$$\text{£ } 1.75$$

(Total for Question 20 is 4 marks)



DO NOT WRITE IN THIS AREA

DO NOT WRITE IN THIS AREA

DO NOT WRITE IN THIS AREA

21 (a) Write 84 as a product of its prime factors.

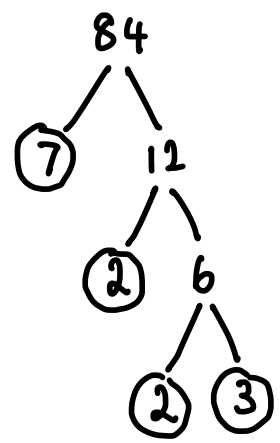

$2 \times 2 \times 3 \times 7$

$2 \times 2 \times 3 \times 7$

(2)

(b) Find the lowest common multiple (LCM) of 60 and 84

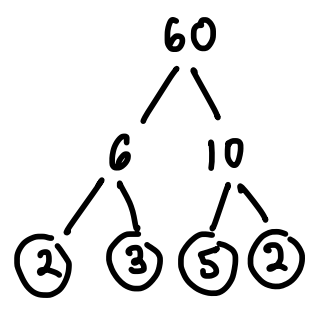

2 × 2 × 3 × 5 = 60

2 × 2 × 3 × 7 = 84

HCF =  $2 \times 2 \times 3$   
= 12

LCM = HCF × other prime factors  
=  $12 \times 5 \times 7$   
= 420

420

(2)

(Total for Question 21 is 4 marks)



$$22 \quad \mathcal{E} = \{1, 2, 3, 4, 5, 6, 7, 8, 9, 10\}$$

$$A = \{\text{even numbers}\} = \{2, 4, 6, 8, 10\}$$

$$B = \{\text{factors of 10}\} = \{1, 2, 5, 10\}$$

(a) Complete the Venn diagram for this information.

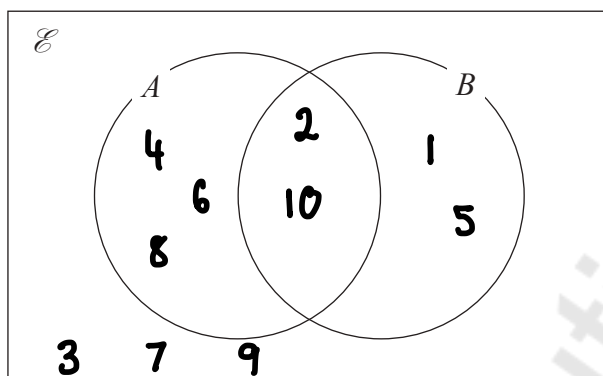

(3)

A number is chosen at random from the universal set,  $\mathcal{E}$

(b) Find the probability that this number is in the set  $A \cap B$

$$\hookrightarrow \frac{F}{D/P}$$

=

↑  
and  
(intersection)

$$\frac{\text{no. of elements intersection}}{\text{total elements}} = \frac{2}{10}$$

$$\frac{2}{10}$$

(2)

(Total for Question 22 is 5 marks)



DO NOT WRITE IN THIS AREA

DO NOT WRITE IN THIS AREA

DO NOT WRITE IN THIS AREA

23 Carlo puts tins into small boxes and into large boxes.

He puts 6 tins into each small box.  
He puts 20 tins into each large box.

Carlo puts a total of 3000 tins into the boxes so that

$$\text{number of tins in small boxes} : \text{number of tins in large boxes} = 2:3$$

Carlo says that less than 30% of the boxes filled with tins are large boxes.

Is Carlo correct?

You must show all your working.

$$3000 \text{ tins} \quad \begin{matrix} S & L \\ 2 & 3 \end{matrix}$$

S  $\boxed{600 \mid 600} = 1200$       5 parts       $3000 \div 5 = 600$

L  $\boxed{600 \mid 600 \mid 600} = 1800$

$$1200 \div 6 = 200 \text{ small boxes}$$

$$1800 \div 20 = 90 \text{ large boxes}$$

290 boxes total

$$\frac{90}{290} \times 100 = 31.034... \%$$

Carlo is incorrect.  $31\% > 30\%$ .

(Total for Question 23 is 5 marks)



24 (a) Complete the table of values for  $y = 5 - x^3$

x	-2	-1	0	1	2
y	13	6	5	4	-3

$\uparrow$   $5 - (-2)^3$        $\uparrow$   $5 - (0)^3$        $\uparrow$   $5 - (1)^3$        $\uparrow$   $5 - (2)^3$

(2)

(b) On the grid below, draw the graph of  $y = 5 - x^3$  for values of  $x$  from  $-2$  to  $2$

- $(-2, 13)$
- $(-1, 6)$
- $(0, 5)$
- $(1, 4)$
- $(2, -3)$

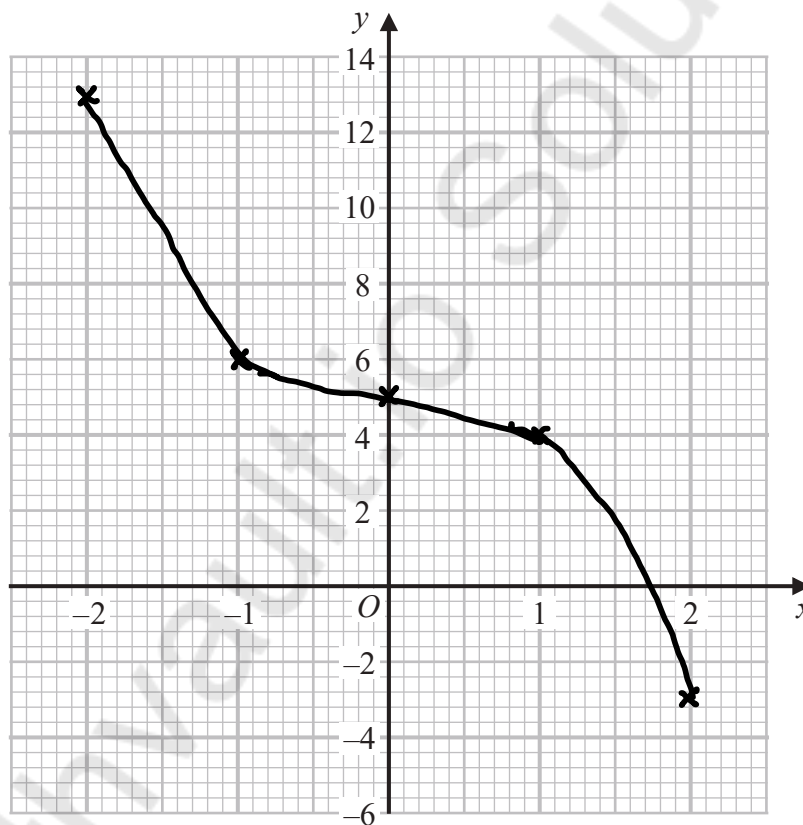

(2)

(Total for Question 24 is 4 marks)



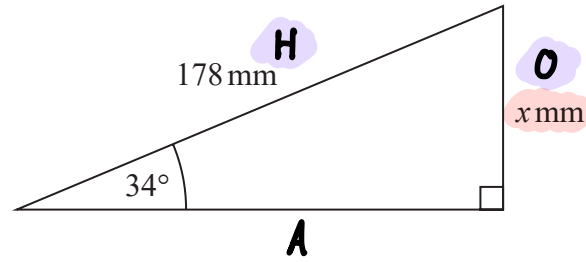

Work out the value of  $x$ .

Give your answer correct to 1 decimal place.

$$\sin(\theta) = \frac{O}{H}$$

~~$$\cos(\theta) = \frac{A}{H}$$~~

~~$$\tan(\theta) = \frac{O}{A}$$~~



$$\sin(34) = \frac{x}{178}$$

$\times 178$

$\times 178$

$$x = 178 \times \sin(34) = 99.536\dots$$

99.5

(Total for Question 25 is 2 marks)

$$26 \quad a = \begin{pmatrix} 3 \\ 4 \end{pmatrix}$$

$$b = \begin{pmatrix} 5 \\ -2 \end{pmatrix}$$

Find  $2a - 3b$  as a column vector.

$$2a = 2 \times a = 2 \times \begin{pmatrix} 3 \\ 4 \end{pmatrix} = \begin{pmatrix} 6 \\ 8 \end{pmatrix}$$

$$3b = 3 \times b = 3 \times \begin{pmatrix} 5 \\ -2 \end{pmatrix} = \begin{pmatrix} 15 \\ -6 \end{pmatrix}$$

$$2a - 3b$$

$$\begin{pmatrix} 6 \\ 8 \end{pmatrix} - \begin{pmatrix} 15 \\ -6 \end{pmatrix} = \begin{pmatrix} -9 \\ 14 \end{pmatrix}$$

$$\begin{pmatrix} -9 \\ 14 \end{pmatrix}$$

(Total for Question 26 is 2 marks)



27 The diagram shows a right-angled triangle and a quarter circle.

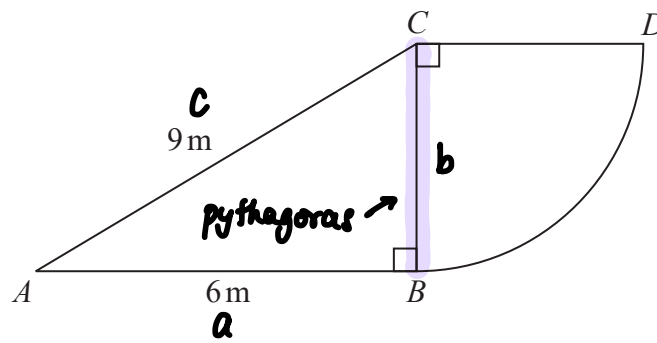

The right-angled triangle  $ABC$  has angle  $ABC = 90^\circ$

The quarter circle has centre  $C$  and radius  $CB$ .

Work out the area of the quarter circle.  $\leftarrow \pi r^2 \div 4 \quad r = ?$

Give your answer correct to 3 significant figures.

You must show all your working.

$$\begin{aligned} a^2 + b^2 &= c^2 \\ 6^2 + b^2 &= 9^2 \\ -6^2 & \quad -6^2 \\ b^2 &= 9^2 - 6^2 \\ \sqrt{\quad} & \quad \sqrt{\quad} \\ b &= \sqrt{9^2 - 6^2} \\ &= \sqrt{81 - 36} \\ &= \sqrt{45} \end{aligned}$$

$$r = \sqrt{45}$$

$$\pi r^2 \div 4 = \text{Area}$$

$$\begin{aligned} \pi (\sqrt{45})^2 \div 4 &= 35.3429\dots \\ &= 35.3 \text{ m}^2 \end{aligned}$$

..... **35.3** .....  $\text{m}^2$

(Total for Question 27 is 4 marks)



DO NOT WRITE IN THIS AREA

DO NOT WRITE IN THIS AREA

DO NOT WRITE IN THIS AREA

28 Each exterior angle of a regular polygon is  $15^\circ$

Work out the number of sides of the polygon.

All ext. angles sum to  $360^\circ$

$$\text{Sides} = \frac{360}{15}$$

$$= 24$$

24

(Total for Question 28 is 2 marks)

29 Write down the gradient of the line with equation  $y = 2x + 3$

$$y = mx + c$$

$\swarrow$  m  
 $\lrcorner$   
 $\uparrow$   
 gradient

2

(Total for Question 29 is 1 mark)

TOTAL FOR PAPER IS 80 MARKS

Mathvault.io Solutions



Mathvault.io Solutions

**BLANK PAGE**

DO NOT WRITE IN THIS AREA

DO NOT WRITE IN THIS AREA

DO NOT WRITE IN THIS AREA



DO NOT WRITE IN THIS AREA

DO NOT WRITE IN THIS AREA

DO NOT WRITE IN THIS AREA

Mathvault.io Solutions

**BLANK PAGE**



P 6 2 2 7 5 A 0 2 3 2 4

DO NOT WRITE IN THIS AREA

DO NOT WRITE IN THIS AREA

DO NOT WRITE IN THIS AREA

Mathvault.io Solutions

**BLANK PAGE**

