

Please check the examination details below before entering your candidate information

Candidate surname

Other names

Centre Number

Candidate Number

--	--	--	--	--

--	--	--	--	--

Pearson Edexcel Level 1/Level 2 GCSE (9–1)

Friday 7 November 2025

Morning (Time: 1 hour 30 minutes)

Paper
reference

1MA1/2H

Mathematics

PAPER 2 (Calculator)

Higher Tier



You must have: Ruler graduated in centimetres and millimetres, protractor, pair of compasses, pen, HB or B pencil, eraser, calculator, Formulae Sheet (enclosed). Tracing paper may be used.

Total Marks

Instructions

- Use **black** ink or ball-point pen.
- If pencil is used for diagrams/sketches/graphs it must be dark (HB or B).
- **Fill in the boxes** at the top of this page with your name, centre number and candidate number.
- Answer **all** questions.
- Answer the questions in the spaces provided
– *there may be more space than you need.*
- You must **show all your working**.
- Diagrams are **NOT** accurately drawn, unless otherwise indicated.
- **Calculators may be used.**
- If your calculator does not have a π button, take the value of π to be 3.142 unless the question instructs otherwise.

Information

- The total mark for this paper is 80
- The marks for **each** question are shown in brackets
– *use this as a guide as to how much time to spend on each question.*

Advice

- Read each question carefully before you start to answer it.
- Try to answer every question.
- Check your answers if you have time at the end.

Turn over ►

P78238RA

©2025 Pearson Education Ltd.
M:1/1/1/1/1



P 7 8 2 3 8 R A 0 1 2 4



Pearson

Answer ALL questions.

Write your answers in the spaces provided.

You must write down all the stages in your working.

1 (a) Write 5.63×10^7 as an ordinary number.

.....
(1)

(b) Write 0.0000354 in standard form.

.....
(1)

(Total for Question 1 is 2 marks)

2 $A = 2 \times 15$
 $B = 8 \times 5 \times 7$

Write AB as a product of its prime factors.

.....
(Total for Question 2 is 2 marks)

DO NOT WRITE IN THIS AREA

DO NOT WRITE IN THIS AREA

DO NOT WRITE IN THIS AREA



3 There are only black pens, green pens, red pens, pink pens and orange pens in a box.

Kate is going to take at random a pen from the box.

The table shows the probability that the pen will be red.

Colour	black	green	red	pink	orange
Probability			0.27		

number of black pens : number of green pens : number of red pens = 5 : 2 : 3

The number of pink pens is four times the number of orange pens.

Work out the probability that the pen will be black or pink.

.....
(Total for Question 3 is 5 marks)



- 4 Trains to London leave a train station every 26 minutes.
Trains to Cardiff leave the same train station every 30 minutes.

A train to London and a train to Cardiff both leave the train station at 7 45 am.

Show that the next time a train to London and a train to Cardiff both leave the train station at the same time is after 2 pm.

(Total for Question 4 is 3 marks)

DO NOT WRITE IN THIS AREA

DO NOT WRITE IN THIS AREA

DO NOT WRITE IN THIS AREA



DO NOT WRITE IN THIS AREA

DO NOT WRITE IN THIS AREA

DO NOT WRITE IN THIS AREA

5 Here is a rectangle.

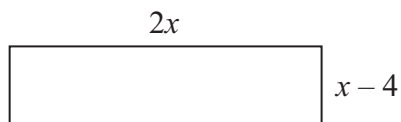

Four of these rectangles and a shaded square are used to make the square $ABCD$ below.

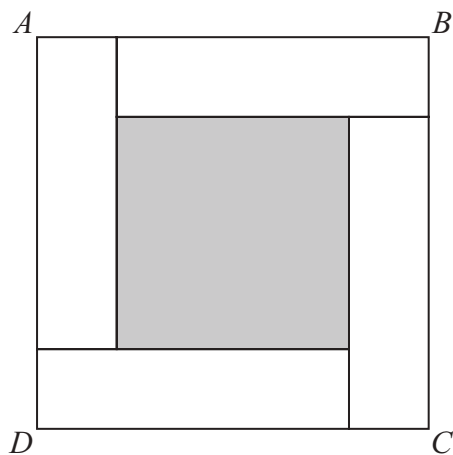

The perimeter of square $ABCD$ is 74 cm.

Work out the perimeter of the shaded square.

..... cm

(Total for Question 5 is 5 marks)



P 7 8 2 3 8 R A 0 5 2 4

- 6 The number of diesel cars sold in the UK decreased by 13% between 2021 and 2022
The number of diesel cars sold in the UK in 2022 was 160 950

Calculate the number of diesel cars sold in the UK in 2021

.....
(Total for Question 6 is 2 marks)

- 7 450 grams of flour is mixed with 180 grams of butter to make 630 grams of pastry mix.

The density of the flour is 0.6 g/cm^3

The density of the pastry mix is 0.672 g/cm^3

Work out the density of the butter.

..... g/cm^3

(Total for Question 7 is 4 marks)



DO NOT WRITE IN THIS AREA

DO NOT WRITE IN THIS AREA

DO NOT WRITE IN THIS AREA

8 The diagram shows a solid cone.

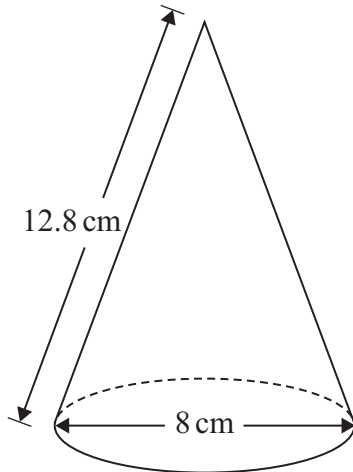

Curved surface area of cone = $\pi r l$

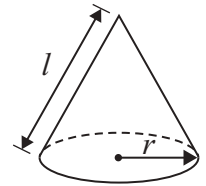

Calculate the total surface area of the cone.
Give your answer correct to 3 significant figures.

..... cm²

(Total for Question 8 is 3 marks)



9 The weight of an elephant is 4100 kilograms, correct to the nearest 50 kilograms.

Complete the error interval for the weight of the elephant.

$$\dots\dots\dots \text{ kg} \leq \text{weight} < \dots\dots\dots \text{ kg}$$

(Total for Question 9 is 2 marks)

10 Here are four equations.

A $y = 4x$

B $y = 5x + 3$

C $y = \frac{5}{x}$

D $y = 3x^2$

The table gives two statements about x and y .

Statement	Equation
y is directly proportional to x	
y is inversely proportional to x	

Match each statement to the letter of the equation that represents the statement.

(Total for Question 10 is 2 marks)



DO NOT WRITE IN THIS AREA

DO NOT WRITE IN THIS AREA

DO NOT WRITE IN THIS AREA

11 (a) Expand and simplify $(x + 4)(x - 3)(x + 6)$

..... (3)

Reggie has to solve the inequality $5 < 4x - 6 < 12$

Here is his working.

$$5 < 4x < 12 + 6$$

$$5 \div 4 < x < 18 \div 4$$

$$1.25 < x < 4.5$$

Reggie's working is wrong.

(b) Describe a mistake Reggie has made in his working.

.....
.....
..... (1)

(Total for Question 11 is 4 marks)



P 7 8 2 3 8 R A 0 9 2 4

12 The table shows information about the weights of 300 pumpkins.

Weight (w kilograms)	Frequency
$0 < w \leq 5$	25
$5 < w \leq 10$	40
$10 < w \leq 15$	130
$15 < w \leq 20$	55
$20 < w \leq 25$	30
$25 < w \leq 30$	20

(a) Complete the cumulative frequency table for this information.

Weight (w kilograms)	Cumulative frequency
$0 < w \leq 5$	
$0 < w \leq 10$	
$0 < w \leq 15$	
$0 < w \leq 20$	
$0 < w \leq 25$	
$0 < w \leq 30$	

(1)

(b) On the grid opposite, draw a cumulative frequency graph for your table.

(2)



DO NOT WRITE IN THIS AREA

DO NOT WRITE IN THIS AREA

DO NOT WRITE IN THIS AREA

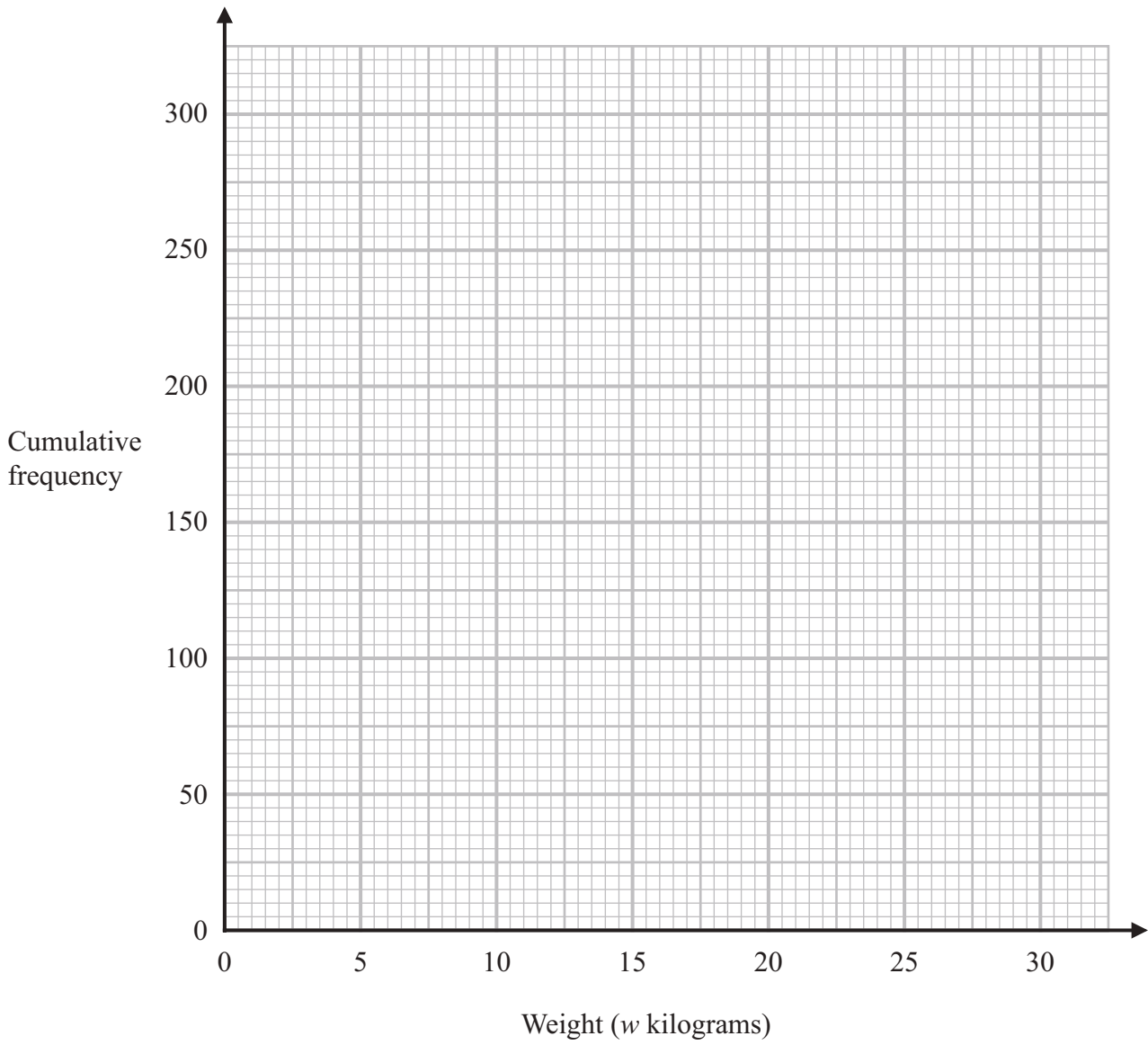

- (c) Use your graph to calculate an estimate for the percentage of the 300 pumpkins that have a weight greater than 18 kilograms.
You must show how you get your answer.

.....%

(3)

(Total for Question 12 is 6 marks)



13 Dave has these seven cards.



Dave is going to use 5 of these cards to make a number that is less than 45 000

How many different 5-digit numbers that are less than 45 000 can Dave make?

.....
(Total for Question 13 is 3 marks)

14 Here are the first six terms of a quadratic sequence.

-4 14 42 80 128 186

Find an expression, in terms of n , for the n th term of this sequence.

.....
(Total for Question 14 is 3 marks)



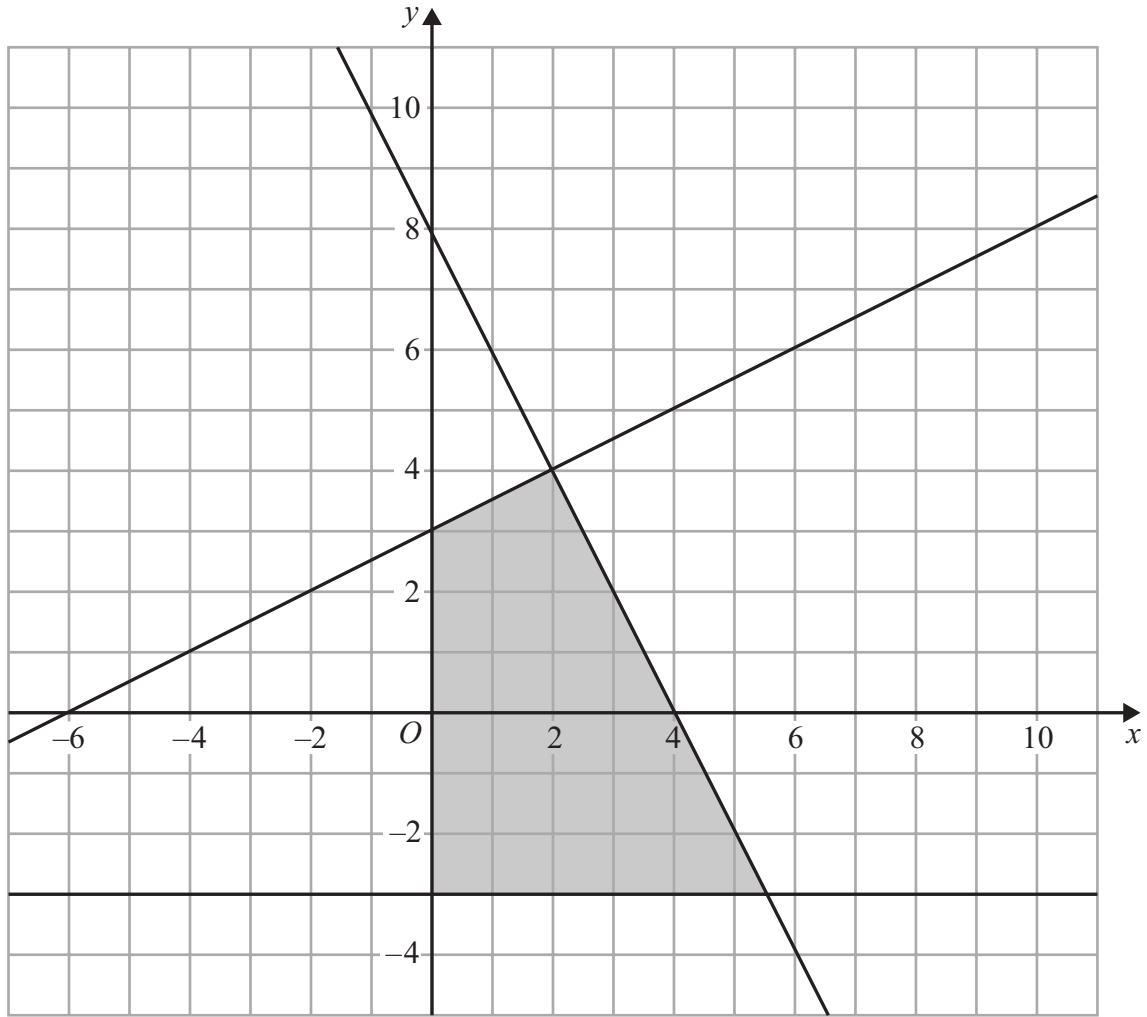

Write down the four inequalities that define the shaded region.

.....

.....

.....

.....

(Total for Question 15 is 4 marks)

DO NOT WRITE IN THIS AREA



16 Here is the velocity–time graph for an object.

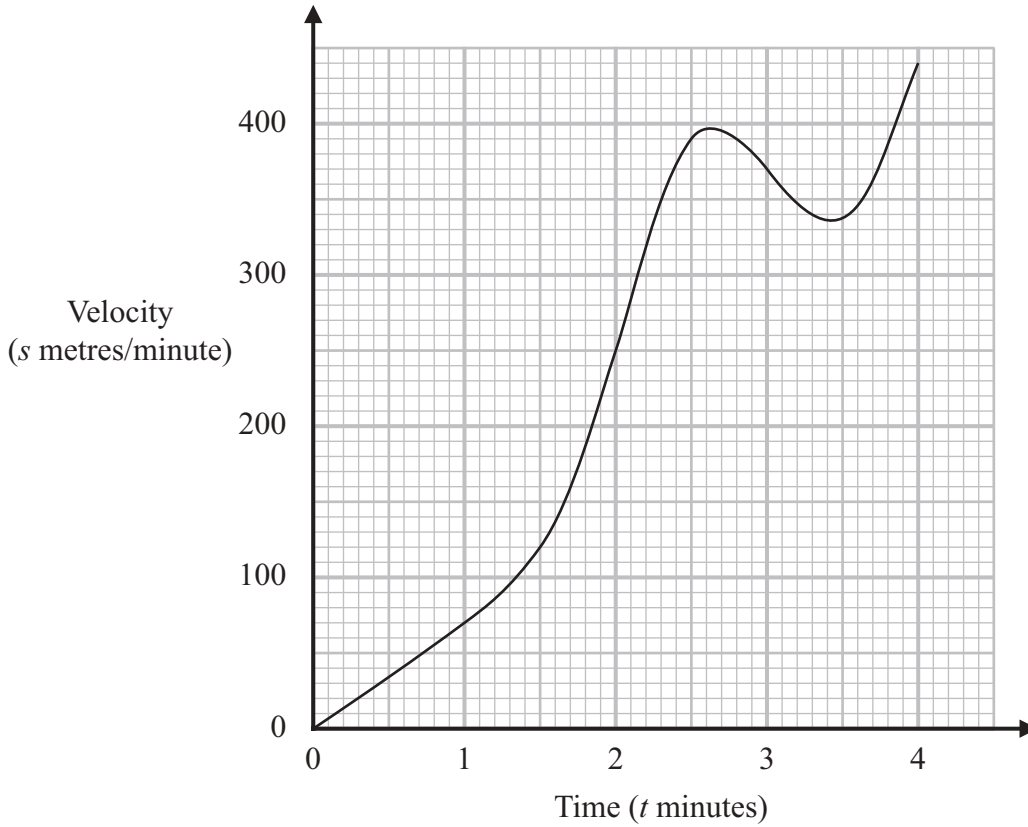

- (a) Work out an estimate for the acceleration, in metres/minute², of the object when $t = 1.5$
 You must show how you get your answer.

..... metres/minute²
 (3)

DO NOT WRITE IN THIS AREA

DO NOT WRITE IN THIS AREA

DO NOT WRITE IN THIS AREA



DO NOT WRITE IN THIS AREA

DO NOT WRITE IN THIS AREA

DO NOT WRITE IN THIS AREA

- (b) Work out an estimate for the distance travelled by the object between $t = 0$ and $t = 4$
Use 4 strips of equal width.

..... metres

(3)

(Total for Question 16 is 6 marks)



- 17 The table shows information about the average skiing speeds, in miles per hour, of 150 people.

Speed (s miles per hour)	Frequency
$10 < s \leq 20$	11
$20 < s \leq 40$	56
$40 < s \leq 65$	60
$65 < s \leq 75$	17
$75 < s \leq 80$	6

- (a) On the grid below, draw a histogram to represent this information.

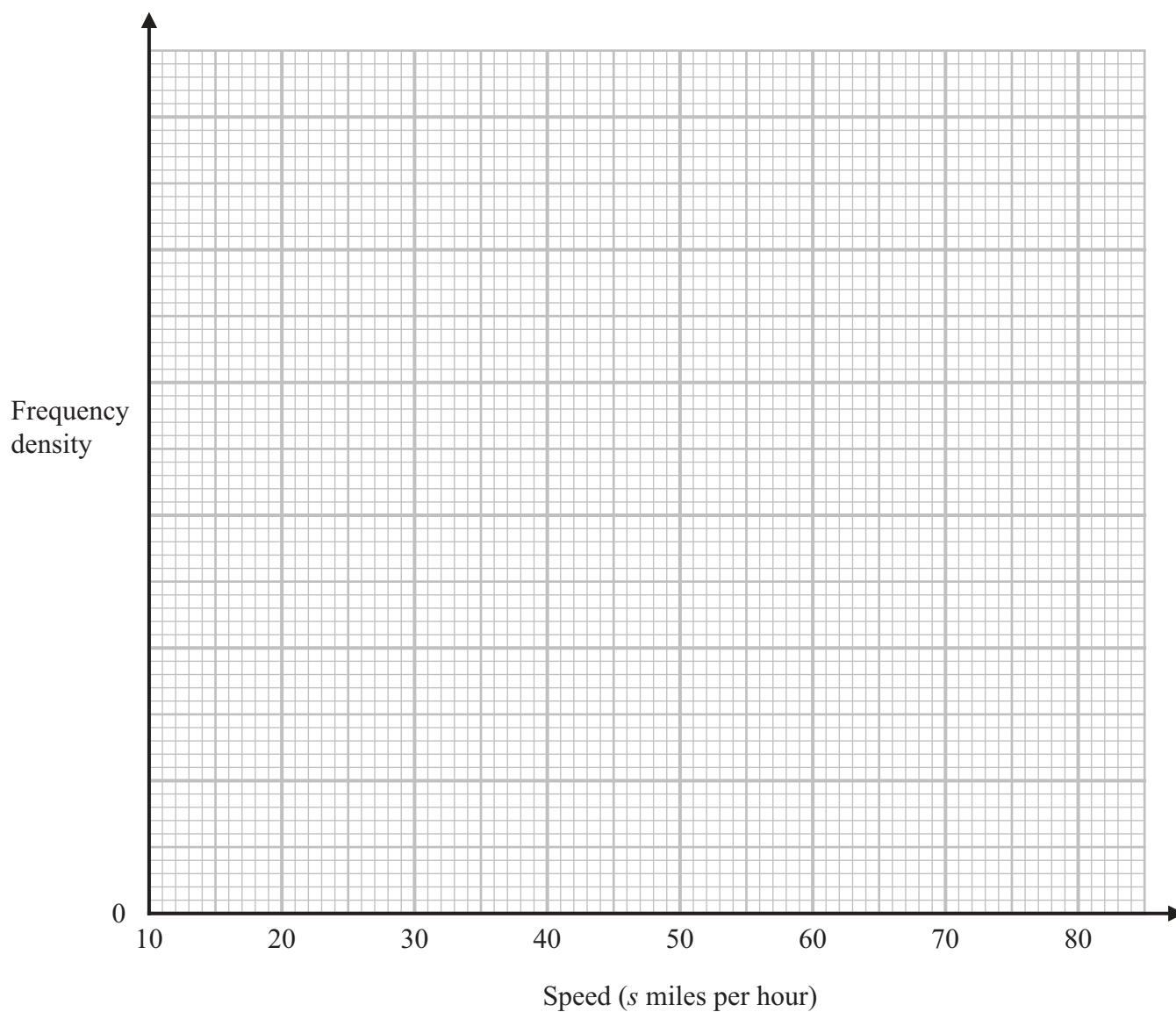

(3)



(b) Find an estimate for the number of people with an average skiing speed between 35 miles per hour and 50 miles per hour.

.....
(3)

(Total for Question 17 is 6 marks)

DO NOT WRITE IN THIS AREA

DO NOT WRITE IN THIS AREA

DO NOT WRITE IN THIS AREA



18 A , B and C are points on a circle with centre O and radius 12 cm.

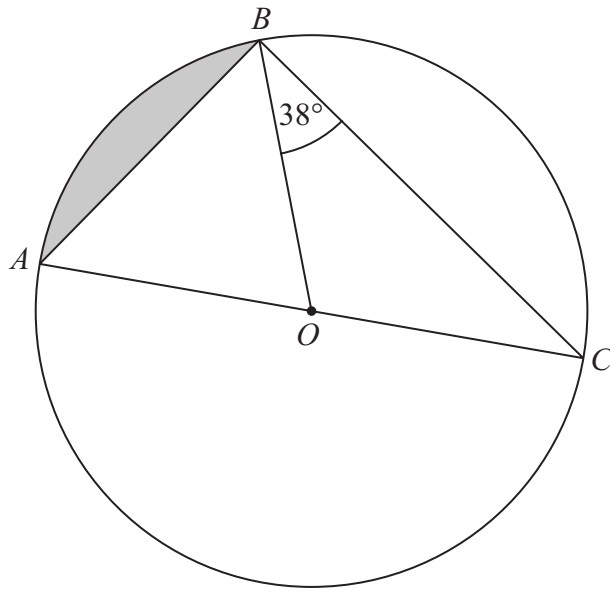

AOC is a diameter of the circle.

Angle $OBC = 38^\circ$

Calculate the area of the shaded segment.
Give your answer correct to 2 decimal places.

..... cm²

(Total for Question 18 is 5 marks)

DO NOT WRITE IN THIS AREA

DO NOT WRITE IN THIS AREA

DO NOT WRITE IN THIS AREA



19

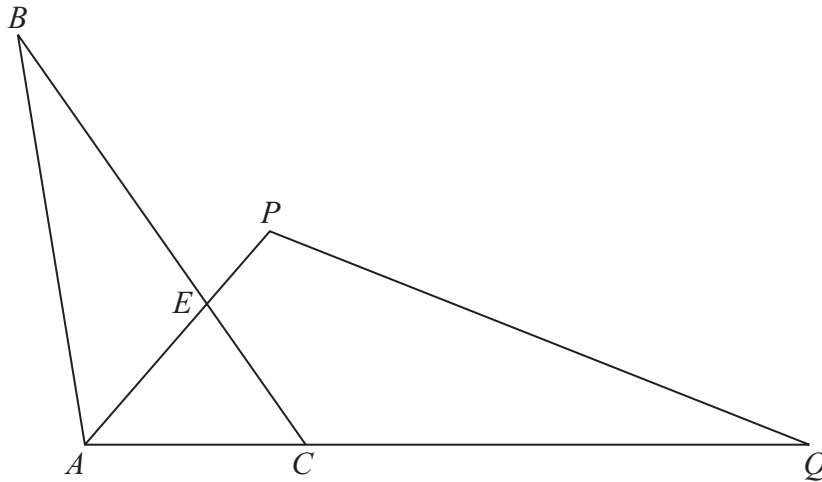

The diagram shows triangle ABC and triangle APQ
 $AQ = 3AC$

The point E lies on the line CB such that $CE:EB = 2:3$

$$\vec{AE} = \mathbf{a} \quad \vec{AC} = \mathbf{b}$$

Express \vec{QB} in terms of \mathbf{a} and \mathbf{b} .

Give your answer in its simplest form.

(Total for Question 19 is 4 marks)



20 The diagram shows a solid pyramid $ABCDE$ on horizontal ground.

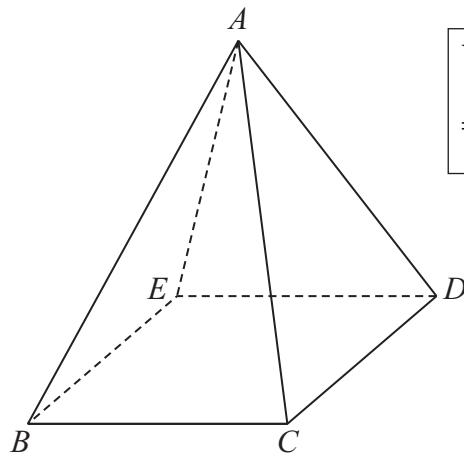

<p>Volume of pyramid $= \frac{1}{3} \text{ area of base} \times \text{perpendicular height}$</p>
--

The base $BCDE$ of the pyramid is a square with sides of length 14 cm.
 The vertex A of the pyramid is vertically above the midpoint of BD .

The angle between AB and the base of the pyramid is 68°

Calculate the volume of the pyramid.
 Give your answer correct to 2 significant figures.

..... cm^3

(Total for Question 20 is 4 marks)

DO NOT WRITE IN THIS AREA

DO NOT WRITE IN THIS AREA

DO NOT WRITE IN THIS AREA



DO NOT WRITE IN THIS AREA

DO NOT WRITE IN THIS AREA

DO NOT WRITE IN THIS AREA

21 The straight line **L** has equation $2x + y = 5$
C is a circle with centre the origin and radius 6

L and C intersect at point *A* and at point *B*.

Find the coordinates of point *A* and the coordinates of point *B*.
Give your coordinates correct to 2 decimal places.

Point *A* (..... ,

Point *B* (..... ,

(Total for Question 21 is 5 marks)

TOTAL FOR PAPER IS 80 MARKS



DO NOT WRITE IN THIS AREA

DO NOT WRITE IN THIS AREA

DO NOT WRITE IN THIS AREA

BLANK PAGE



DO NOT WRITE IN THIS AREA

DO NOT WRITE IN THIS AREA

DO NOT WRITE IN THIS AREA

BLANK PAGE



DO NOT WRITE IN THIS AREA

DO NOT WRITE IN THIS AREA

DO NOT WRITE IN THIS AREA

BLANK PAGE

