

## GCSE (9–1) Mathematics

J560/06 Paper 6 (Higher Tier)

**Tuesday 13 June 2017 – Morning**

**Time allowed: 1 hour 30 minutes**



**You may use:**

- A scientific or graphical calculator
- Geometrical instruments
- Tracing paper



First name										
Last name										
Centre number						Candidate number				

### INSTRUCTIONS

- Use black ink. You may use an HB pencil for graphs and diagrams.
- Complete the boxes above with your name, centre number and candidate number.
- Answer **all** the questions.
- Read each question carefully before you start to write your answer.
- Where appropriate, your answers should be supported with working. Marks may be given for a correct method even if the answer is incorrect.
- Write your answer to each question in the space provided.
- Additional paper may be used if required but you must clearly show your candidate number, centre number and question number(s).
- Do **not** write in the barcodes.

### INFORMATION

- The total mark for this paper is **100**.
- The marks for each question are shown in brackets [ ].
- Use the  $\pi$  button on your calculator or take  $\pi$  to be 3.142 unless the question says otherwise.
- This document consists of **20** pages.

Answer **all** the questions.

- 1 This table shows the populations of the four countries of the UK in 2012. All values are given correct to 3 significant figures.

Country	Population
England	$5.35 \times 10^7$
Wales	$3.07 \times 10^6$
Scotland	$5.31 \times 10^6$
Northern Ireland	$1.82 \times 10^6$

- (a) Write the population of England as an ordinary number.

5,350,000

(a) ..... 53,500,000 ..... [1]

- (b) Work out the total population of Wales, Scotland and Northern Ireland. Give your answer in standard form.

$$(3.07 \times 10^6) + (5.31 \times 10^6) + (1.82 \times 10^6) = \underline{10200000}$$

(b) .....  $1.02 \times 10^7$  ..... [2]

- (c) The total population of the UK is predicted to reach 73.3 million in 2037.

Calculate the predicted percentage increase in the UK population from 2012 to 2037. Give your answer correct to 2 significant figures.

$$\text{In 2037, } 73,300,000 = 7.33 \times 10^7$$

$$\begin{aligned} \text{In 2012, } 1.02 \times 10^7 + 5.35 \times 10^7 &= 63700000 \\ &= 6.37 \times 10^7 \end{aligned}$$

$$\frac{(7.33 \times 10^7) - (6.37 \times 10^7)}{(6.37 \times 10^7)} \times 100 = 15.0706... \approx 15$$

(c) ..... 15 ..... % [4]

$$\overset{\div 25}{\curvearrowright} 3$$

2 (a) The scale of a map is 1 cm represents 25m.

(i) The length of a path is 240m.

Work out the length, in centimetres, of the path on the map.

$$240m \div 25 = 9.6$$

(a)(i) ..... **9.6** .....cm [1]

(ii) The scale 1 cm represents 25m can be written in the form 1:k.

Find the value of k.

$$\begin{array}{l} \text{L} \rightarrow 2500 \text{ cm} \\ \times 100 \end{array}$$

$$1 : 2500$$

(ii) k = ..... **2500** ..... [1]

~~(b)~~ The scale drawing represents a ~~park~~.

Scale: 1 cm represents 25 m

$$\overset{\div 25}{\curvearrowright}$$

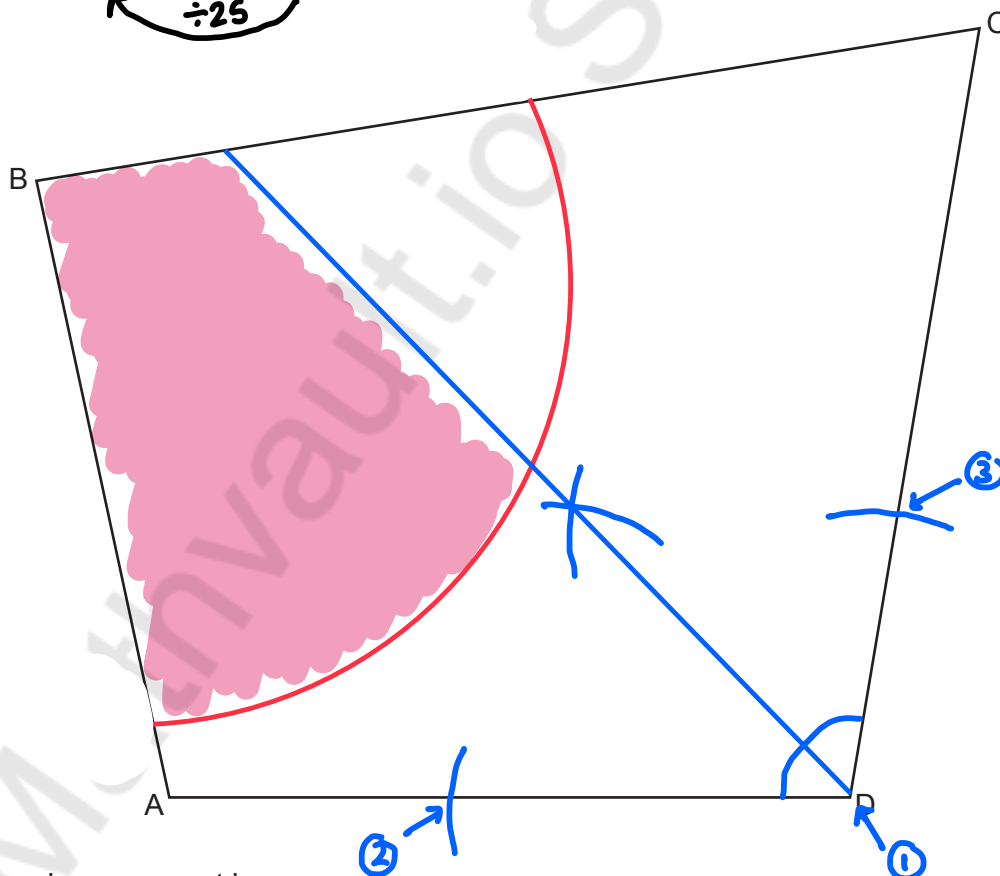

A new play area must be

- no more than 150m from B  **$150 \div 25 = 6\text{cm}$**
- closer to AD than to CD. **angle bisector**

Construct and shade the region where the play area can be positioned.  
Show all your construction lines.

[5]

- 3 (a) The owner of a tourist attraction records the amount of rainfall, in millimetres, and the number of visitors each day. The results for 10 days are shown in the scatter diagram.

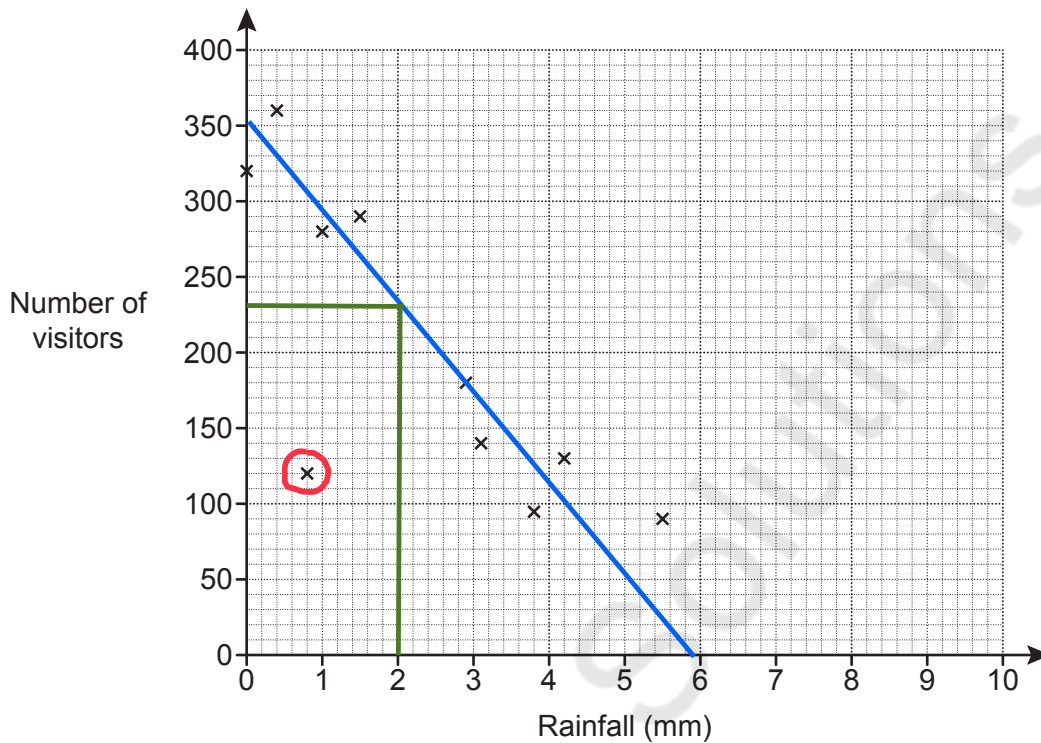

- (i) Circle the outlier on the scatter diagram. [1]
- (ii) The owner claims that he would expect around 320 visitors on a day with 2 mm of rainfall.

Does the scatter diagram support his statement?  
Explain how you made your decision.

No, 230 visitors expected. [2]

- (iii) Explain why the scatter diagram should not be used to estimate the number of visitors on a day with 9 mm of rainfall.

Outside of range of data. [1]

- (b) The pie chart summarises information about the visitors to the tourist attraction on a different day.

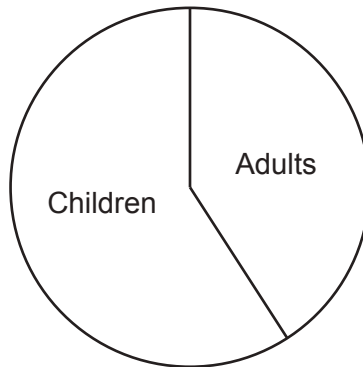

Explain why the pie chart cannot be used to work out how many adults visited on that day.

..... **Number of children not known.** .....  
 ..... [1]

- 4 In a school,  $\frac{2}{3}$  of the students study a language.

Of those students who study a language,  $\frac{2}{5}$  study Spanish.

Find the ratio of students who study Spanish to students who do not study Spanish.

$$\frac{2}{5} \times \frac{2}{3} = \frac{4}{15}$$

$$\frac{4}{15} \text{ spanish} \quad \frac{11}{15} \text{ do not}$$

..... **4** : **11** ..... [3]

- 5 Point A has coordinates  $(-4, 6)$  and point B has coordinates  $(8, 3)$ .

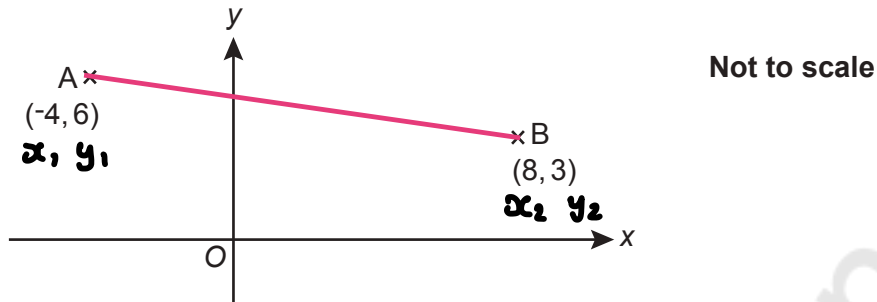

- (a) (i) Find the gradient of line AB.

$$m = \frac{y_2 - y_1}{x_2 - x_1} = \frac{3 - 6}{8 - (-4)} = \frac{-3}{12} = -\frac{1}{4}$$

(a)(i) .....  $-\frac{1}{4}$  [2]

- (ii) Find the equation of line AB.

$$y = mx + c \quad m = -\frac{1}{4} \quad (8, 3)$$

$$3 = -\frac{1}{4}(8) + c$$

$$3 = -2 + c$$

$$+2 \quad +2$$

$$c = 5$$

(ii) .....

$$y = -\frac{1}{4}x + 5$$

[2]

- (b) Point P has coordinates  $(0, -2)$ .

y-intercept = -2

Write down the equation of the line parallel to line AB that passes through P.

same gradient  
 $-\frac{1}{4}$

(b) .....

$$y = -\frac{1}{4}x - 2$$

[2]

- 6 (a) This is a fair 5-sided spinner.

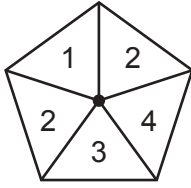

Ciara spins the spinner twice and records the product of the two scores.

- (i) Complete the table.

		First spin				
		1	2	2	3	4
Second spin	1	1	2	2	3	4
	2	2	4	4	6	8
	2	2	4	4	6	8
	3	3	6	6	9	12
	4	4	8	8	12	16

[2]

- (ii) Find the probability that the product is a multiple of 3.

9 out of 25 outcomes

$$\frac{9}{25}$$

(a)(ii) ..... [2]

- (b) Ciara makes a different fair 5-sided spinner. She spins the spinner twice and records the product of the two scores.

Ciara says

The probability that the product is negative is 0.48.

Write numbers on the spinner below so that Ciara's statement is correct.

$$p(\text{neg.}) = 0.48 = \frac{48}{100} = \frac{12}{25}$$

12 negative outcomes

13 positive outcomes

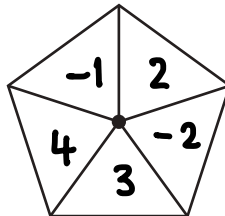

x	-1	2	-2	3	4
-1	1	-2	2	-3	-4
2	-2	4	-4	6	8
-2	2	-4	4	-6	-8
3	-3	6	-6	9	12
4	-4	8	-8	12	16

[3]

- 7 (a) Complete the table for  $y = x^2 - 2x$ .

x	-1	0	1	2	3	4
y	3	0	-1	0	3	<b>8</b>

↑ [1]  
 $y = (4)^2 - 2(4)$

- (b) Draw the graph of  $y = x^2 - 2x$  for  $-1 \leq x \leq 4$ .

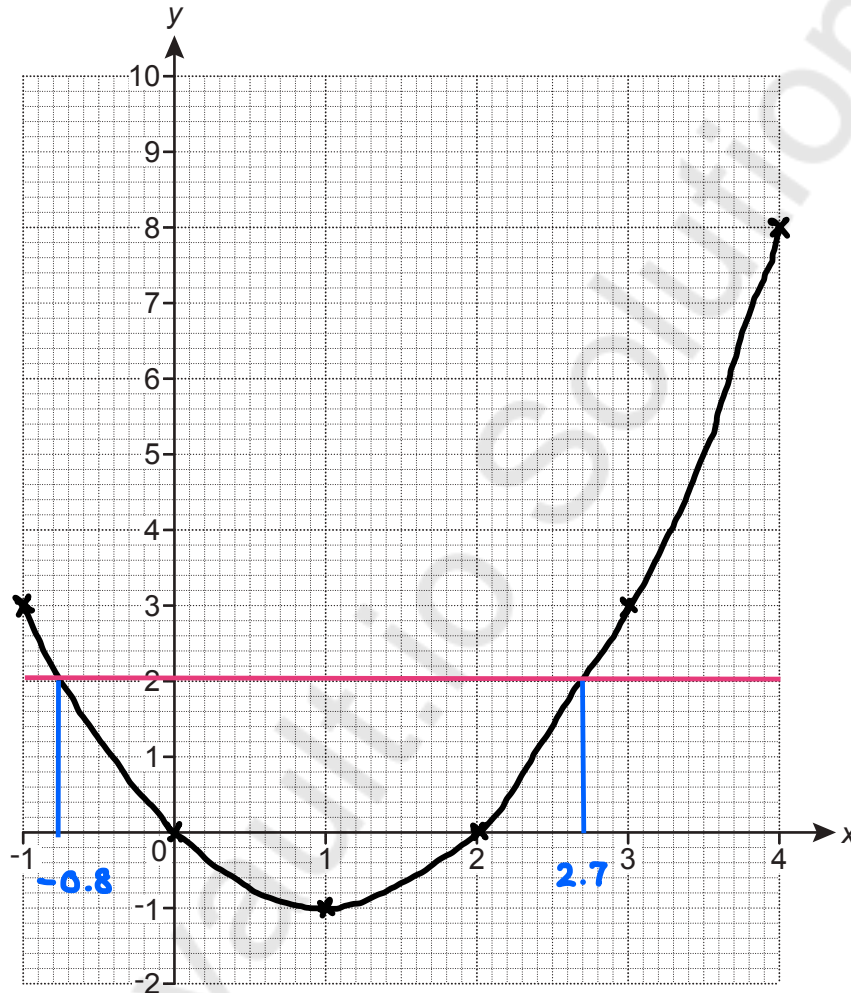

- (c) Use your graph to solve  $x^2 - 2x = 2$ .  
 $x^2 - 2x = y$   
 Draw  $y = 2$

(c)           -0.8 and 2.7           [2]

- 8 The object below is made from a square-based pyramid joined to a cuboid.

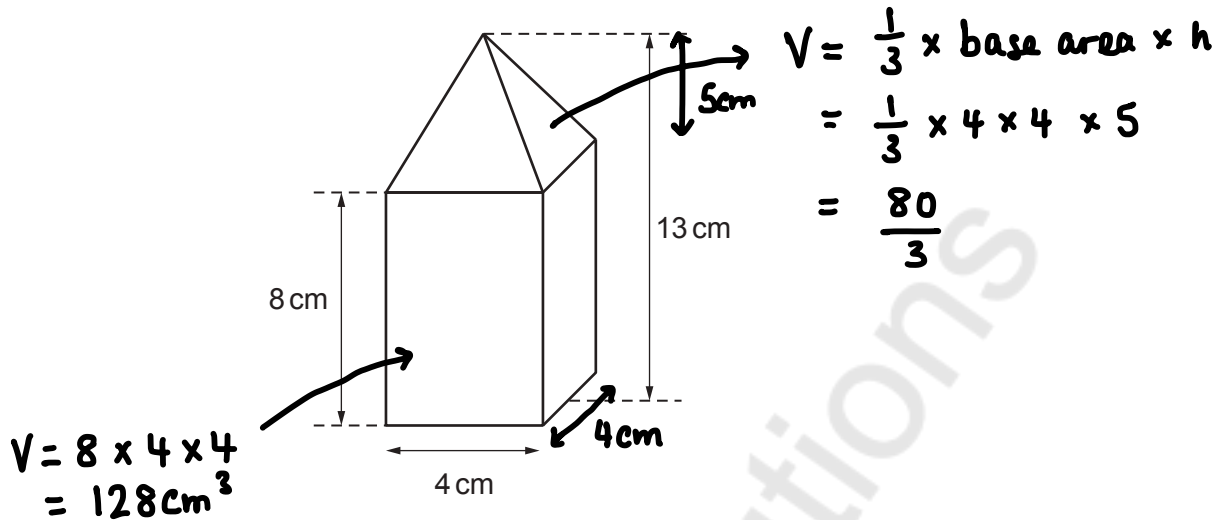

The base of the cuboid and the base of the pyramid are both squares of side 4 cm. The height of the cuboid is 8 cm and the total height of the object is 13 cm. The total mass of the object is 158 g.

The cuboid is made from wood with density  $0.67 \text{ g/cm}^3$ . The pyramid is made from granite.

Calculate the density of the granite.

[The volume of a pyramid is  $\frac{1}{3} \times \text{area of base} \times \text{perpendicular height}$ .]

	Cuboid	Pyramid	Object
m	$0.67 \times 128$ $85.76 \text{ g}$	$158 - 85.76$ $72.24 \text{ g}$	158 g
D	$0.67 \text{ g/cm}^3$	$\frac{72.24}{80/3} = 2.709$	
v	$128 \text{ cm}^3$	$\frac{80}{3} \text{ cm}^3$	

..... **2.7** .....  $\text{g/cm}^3$  [5]

- 9 (a) Triangle **A** is drawn on the grid.

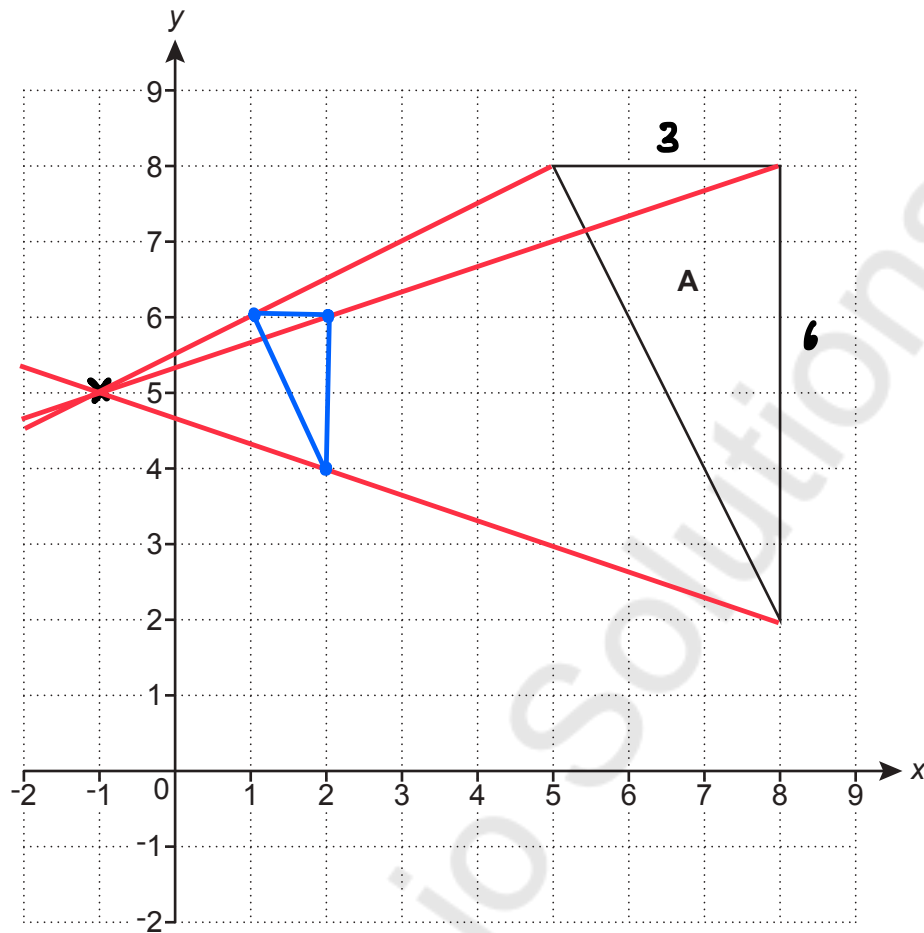

Enlarge triangle **A** with scale factor  $\frac{1}{3}$  and centre of enlargement  $(-1, 5)$ .

[3]

- (b) Prism P and prism Q are similar.  
The ratio of the surface area of prism P to the surface area of prism Q is 1:3.

(i) Jay says

The height of prism P is one third of the height of prism Q.

Explain why he is wrong.

..... Height ratio is the square root of surface .....  
..... area ratio ..... [1]

(ii) The volume of prism Q is  $86 \text{ cm}^3$ .

Calculate the volume of prism P.

Area  
P : Q  
1 : 3  
√    √

Length  
1 :  $\sqrt{3}$

Volume  
1 :  $3\sqrt{3}$   
     $\div 3\sqrt{3}$

(b)(ii) ..... 16.6 .....  $\text{cm}^3$  [3]

cube

$86 \text{ cm}^3 \div 3\sqrt{3} = 16.55070772$   
 $\approx 16.6$

10 Ana records the amount of money spent by 140 customers in her shop on one day.

Amount spent (£a)	Frequency
$0 < a \leq 5$	35
$5 < a \leq 10$	42
$10 < a \leq 15$	20
$15 < a \leq 20$	18
$20 < a \leq 30$	14
$30 < a \leq 50$	11

F. D. (=  $F \div CW$ )

$35 \div 5 = 7$

$42 \div 5 = 8.4$

$20 \div 5 = 4$

$18 \div 5 = 3.6$

$14 \div 10 = 1.4$

$11 \div 20 = 0.55$

CW F FD

(a) Draw a histogram to represent this information.

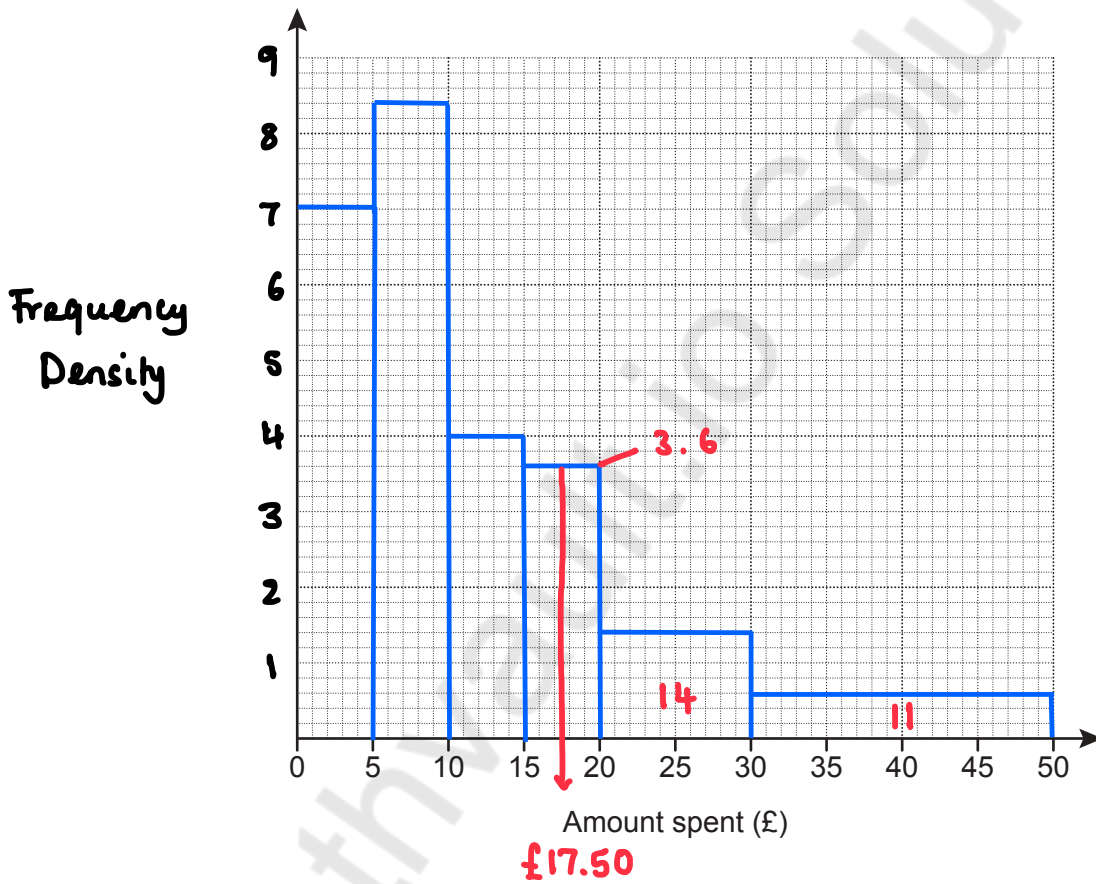

$35 - 25 = 10$   
 $CW = \frac{F}{FD} = \frac{10}{3.6} = 2.7$

[4]

- (b) Ana wants to offer a discount to the customers who spend the most money in her shop.

Voucher  
Save 10% when you  
spend more than £...

She wants to give the discount to approximately 25% of her customers.

Suggest a suitable amount of money for Ana to use on her voucher.  
Justify your decision.

$$0.25 \times 140 = 35 \text{ customers}$$

£17.50 since top 35 customers spend £17.50 or more. [4]

- 11 Sunil makes 7.5 litres of soup, correct to the nearest 0.5 litre. He serves the soup in 300 ml portions, correct to the nearest 10 ml. 24 people order this soup.

Does Sunil definitely have enough soup to serve the 24 people? Show how you decide.

$$L \xrightarrow{\times 1000} ml$$

$$7.5L = 7500ml$$

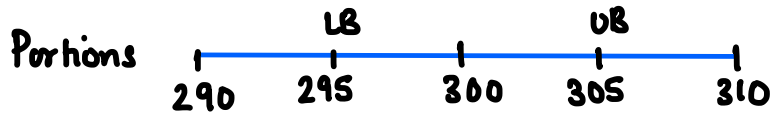
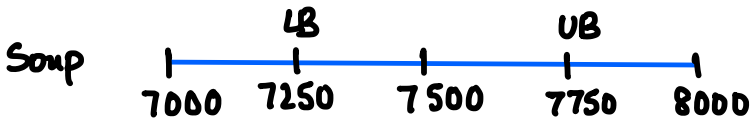

$$\begin{aligned} \text{Smallest number of people} &= \frac{\text{Soup}_{LB}}{\text{Portions}_{UB}} \\ &= \frac{7250}{305} \\ &= 23.77\dots \end{aligned}$$

..... No. 23.77... < 24. .... [4]

- 12  $y$  is inversely proportional to the square of  $x$ .

Complete the table.

$x$	10	6	15
$y$	9	25	4

$$\begin{aligned} y &\propto \frac{1}{x^2} & y &= \frac{900}{x^2} \\ y &= \frac{k}{x^2} & y &= \frac{900}{6^2} \\ 9 &= \frac{k}{10^2} & &= 25 \\ \times 10^2 & \times 10^2 & & \\ k &= 900 & 4 &= \frac{900}{x^2} \\ & & 4x^2 &= 900 \\ & & x^2 &= \frac{900}{4} \\ & & \sqrt{\quad} & \sqrt{\quad} \\ x &= \sqrt{\frac{900}{4}} & & \\ & & & = \pm 15 \end{aligned}$$

[4]

- 13 A and B are points on the circumference of a circle, centre O. CA and CB are tangents to the circle.

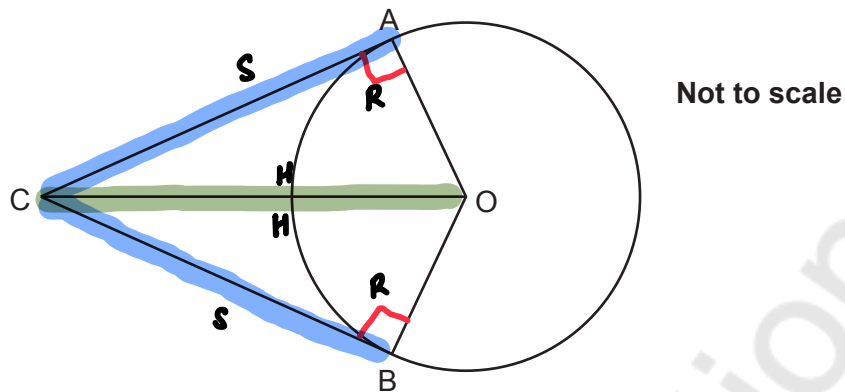

Prove that triangle OAC is congruent to triangle OBC.

- $OC$  is common / shared [side]  $H$
- $\angle OAC = \angle OBC$  - tangent meets radius at  $90^\circ$  [angle]  $R$
- $CA = CB$  tangents from a point to the circle [side]  $S$

Congruent - RHS.

[4]

14 Here is a function.

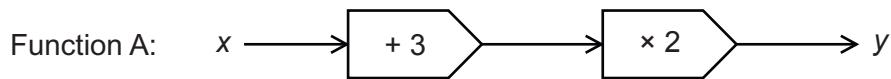

(a) Complete the table of values for function A.

$x$	$y$
-5	-4
2.5	11

$$11 \div 2 - 3$$

[2]

Here is another function.

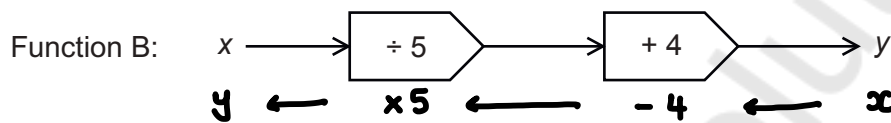

(b) Find the inverse function of function B.

$$y = 5(x - 4)$$

[2]

(c) Here is a composite function.

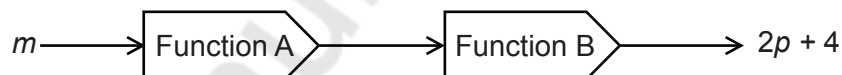

Find an expression for  $m$  in terms of  $p$ .  
Give your answer in its simplest form.

Function A

$$2(m + 3)$$

$$2m + 6$$

Function B

$$\frac{2m + 6}{5} + 4 = 2p + 4$$

$$\frac{2m + 6}{5} = 2p$$

$$2m + 6 = 10p$$

$$(c) \quad m = \dots 5p - 3 \dots [4]$$

$$2m = 10p - 6$$

$$\div 2 \quad \div 2$$

$$m = 5p - 3$$

- 15 (a) Sketch the graph of  $y = \sin x$  for  $0^\circ \leq x \leq 360^\circ$ .

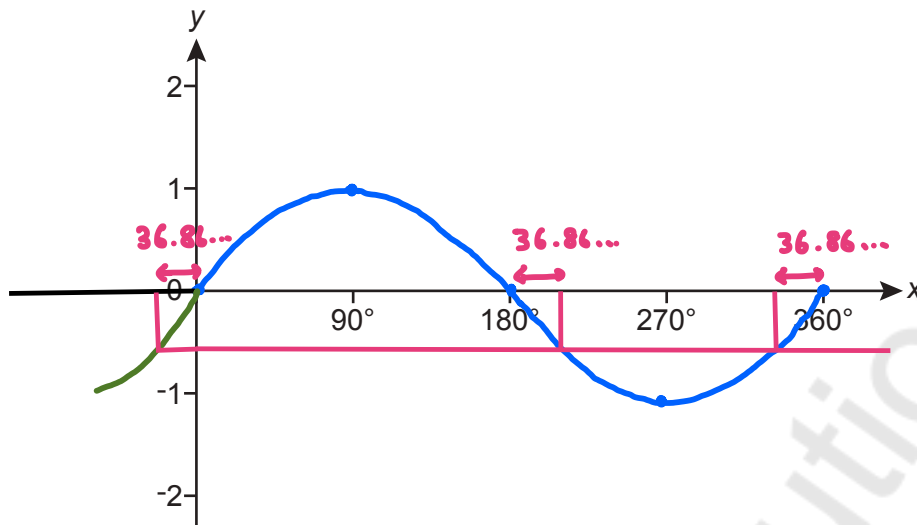

[2]

- (b) Solve the equation  $5 \sin x = -3$ .  
Give all of the solutions in the range  $0^\circ \leq x \leq 360^\circ$ .

$$5 \sin x = -3$$

$$\div 5 \qquad \div 5$$

$$\sin x = \frac{-3}{5}$$

$$x = \sin^{-1}\left(-\frac{3}{5}\right)$$

$$= -36.86\dots$$

$$180^\circ + 36.86\dots = 216.869\dots$$

$$\approx 217^\circ$$

$$360 - 36.86\dots = 323.130\dots$$

$$\approx 323^\circ$$

(b)  $x = \mathbf{217} \dots^\circ$  or  $x = \mathbf{323} \dots^\circ$  [4]

16 (a) Simplify.

$$\frac{3y^3}{y^{-4}} = 3 \frac{y^3}{y^{-4}} = y^{3-(-4)} = y^7$$

(a) .....  $3y^7$  ..... [1]

(b) Write as a single fraction in its simplest form.

$$\frac{3}{x-1} + \frac{4}{x+2}$$

$$\frac{3(x+2) + 4(x-1)}{(x-1)(x+2)}$$

$$\frac{3x+6+4x-4}{(x-1)(x+2)}$$

$$\frac{7x+2}{(x-1)(x+2)}$$

(b) .....  $\frac{7x+2}{(x-1)(x+2)}$  ..... [3]17 Show that  $\frac{\sqrt[3]{81}}{3}$  can be written as  $3^{\frac{1}{3}}$ . [3]

$$\sqrt[3]{81} = 81^{\frac{1}{3}}$$

$$= (3^4)^{\frac{1}{3}}$$

$$= 3^{4 \times \frac{1}{3}}$$

$$= 3^{\frac{4}{3}}$$

$$\frac{3^{\frac{4}{3}}}{3^1}$$

$$= 3^{\frac{4}{3}-1}$$

$$= 3^{\frac{1}{3}}$$

- 18 Alvin has a crate in the shape of a cuboid. The crate is open at the top. The internal dimensions of the crate are 46 cm long by 46 cm wide by 55 cm high.

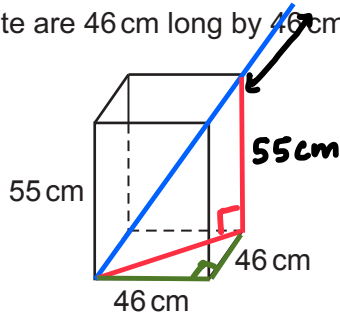

Alvin has a stick of length 95 cm. Alvin places the stick in the crate so that the shortest possible length extends out above the top of the crate.

- (a) Calculate the length of the stick that extends out of the crate.

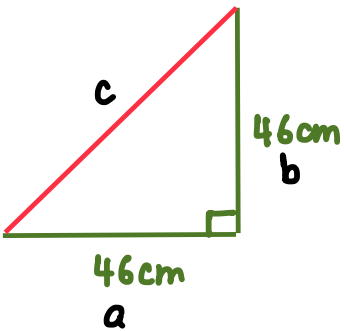

$$a^2 + b^2 = c^2$$

$$46^2 + 46^2 = c^2$$

$$\sqrt{46^2 + 46^2} = c$$

$$46\sqrt{2} = c$$

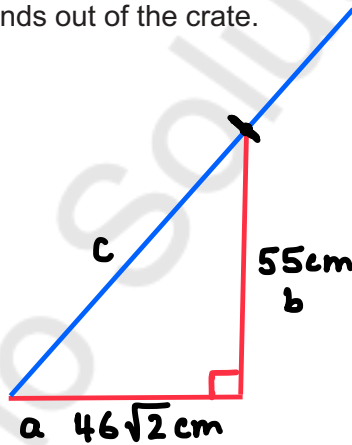

$$(46\sqrt{2})^2 + 55^2 = c^2$$

$$\sqrt{(46\sqrt{2})^2 + 55^2} = c$$

$$c = 85.18802733$$

$$95 \text{ cm} - 85.18... \text{ cm} = 9.811... \text{ cm}$$

- (a) ..... 9.8 ..... cm [4]

- (b) Calculate the angle the stick makes with the base of the crate.

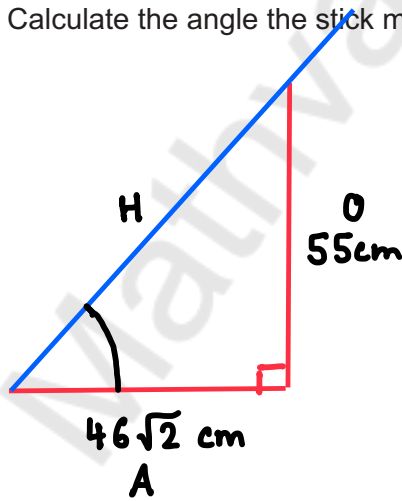

$$\frac{S^O}{H} = \frac{C^A}{H} = \frac{T^O}{A}$$

$$\downarrow$$

$$\tan \theta = \frac{O}{A}$$

$$\tan \theta = \frac{55}{46\sqrt{2}}$$

$$\theta = \tan^{-1} \left( \frac{55}{46\sqrt{2}} \right) = 40.21297464^\circ$$

- (b) ..... 40.2 ..... ° [3]

PLEASE DO NOT WRITE ON THIS PAGE

---

# OCR

Oxford Cambridge and RSA

## Copyright Information

OCR is committed to seeking permission to reproduce all third-party content that it uses in its assessment materials. OCR has attempted to identify and contact all copyright holders whose work is used in this paper. To avoid the issue of disclosure of answer-related information to candidates, all copyright acknowledgements are reproduced in the OCR Copyright Acknowledgements Booklet. This is produced for each series of examinations and is freely available to download from our public website ([www.ocr.org.uk](http://www.ocr.org.uk)) after the live examination series.

If OCR has unwittingly failed to correctly acknowledge or clear any third-party content in this assessment material, OCR will be happy to correct its mistake at the earliest possible opportunity.

For queries or further information please contact the Copyright Team, First Floor, 9 Hills Road, Cambridge CB2 1GE.

OCR is part of the Cambridge Assessment Group; Cambridge Assessment is the brand name of University of Cambridge Local Examinations Syndicate (UCLES), which is itself a department of the University of Cambridge.