

## GCSE (9–1) Mathematics

J560/02 Paper 2 (Foundation Tier)

**Monday 6 November 2017 – Morning**

**Time allowed: 1 hour 30 minutes**



**You may use:**

- Geometrical instruments
- Tracing paper

**Do not use:**

- A calculator



First name				
Last name				
Centre number				
Candidate number				

### INSTRUCTIONS

- Use black ink. You may use an HB pencil for graphs and diagrams.
- Complete the boxes above with your name, centre number and candidate number.
- Answer **all** the questions.
- Read each question carefully before you start to write your answer.
- Where appropriate, your answers should be supported with working. Marks may be given for a correct method even if the answer is incorrect.
- Write your answer to each question in the space provided.
- If additional space is required, you should use the lined page(s) at the end of this booklet. The question number(s) must be clearly shown.
- Do **not** write in the barcodes.

### INFORMATION

- The total mark for this paper is **100**.
- The marks for each question are shown in brackets [ ].
- This document consists of **20** pages.

Answer **all** the questions.

- 1 A fair spinner has six sides.  
They are labelled 1, 1, 2, 4, 4, 5.

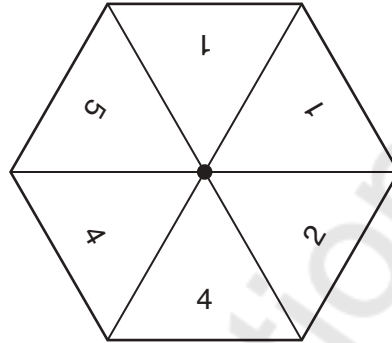

The diagram shows a probability scale.

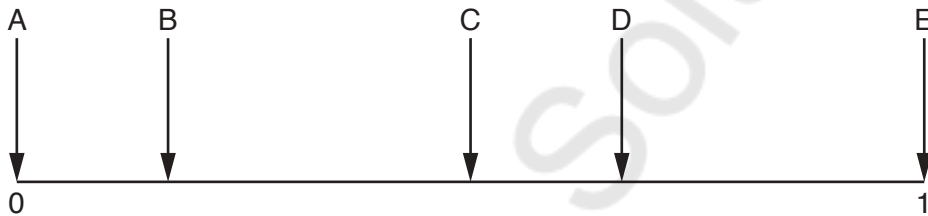

Which arrow shows the probability of

- (a) scoring a 2,

$$\frac{1}{6}$$

(a) ..... **B** ..... [1]

- (b) scoring a number less than 6,

$$\frac{6}{6} = 1$$

(b) ..... **E** ..... [1]

- (c) scoring a 1 or a 4?

$$\frac{4}{6}$$

(c) ..... **D** ..... [1]

2 (a) Write down the number of lines of symmetry of this hexagon.

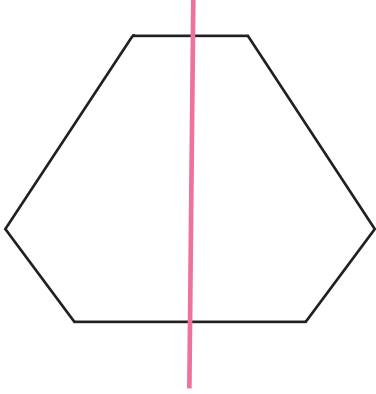

(a) ..... 1 ..... [1]

(b) Write down the order of rotation symmetry of this shape.

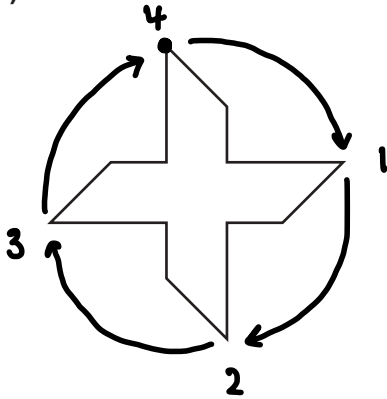

(b) ..... 4 ..... [1]

(c) A triangle has just one line of symmetry.

Write down the mathematical name of this type of triangle.



(c) ..... Isosceles ..... [1]

(d) Sara says

All parallelograms have 2 lines of symmetry and rotation symmetry of order 2.

Explain why Sara is not correct.



..... There are no lines of symmetry. ..... [1]



- 5 Write 0.26 as a fraction.  
Give your answer in its simplest form.

$$\frac{26}{100} \quad \begin{array}{l} \div 2 \\ \div 2 \end{array} \quad \frac{13}{50}$$

$$\frac{13}{50}$$

..... [2]

- 6 (a) Simplify fully.

(i)  $4(c+2d) + 3(3c-5d)$

$$\begin{array}{c} \overbrace{4c + 8d} + \overbrace{9c - 15d} \\ \swarrow \quad \searrow \quad \swarrow \quad \searrow \\ 13c - 7d \end{array}$$

(a)(i) .....  $13c - 7d$  ..... [3]

(ii)  $4a \times 5b$

$$\begin{array}{c} 4 \times 5 \times a \times b \\ 20ab \end{array}$$

(ii) .....  $20ab$  ..... [1]

- (b) Factorise fully.

(i)  $6g + 8h$

$$\text{HCF of } 6 \text{ \& } 8 = 2$$

$$2(3g + 4h)$$

(b)(i) .....  $2(3g + 4h)$  ..... [1]

(ii)  $5x^2 - 15x$

$$\text{HCF of } 5 \text{ \& } 15 = 5$$

$$\text{HCF of } x^2 \text{ \& } x = x$$

$$5x(x - 3)$$

(ii) .....  $5x(x - 3)$  ..... [2]

7 (a) Work out.

(i)  $1 + 4 \div 2$

$$1 + 2$$

(a)(i) ..... **3** ..... [1]

(ii)  $2 + 5 \times (8 - 4)$

$$2 + 5 \times 4$$

$$2 + 20$$

(ii) ..... **22** ..... [1]

(b) Evaluate.

(i)  $2^5$

$$\underbrace{2 \times 2 \times 2}_8 \times \underbrace{2 \times 2}_4$$

(b)(i) ..... **32** ..... [1]

(ii)  $\sqrt{400}$

$$\sqrt{4} = 2$$

$$\sqrt{400} = 20$$

(ii) ..... **20** ..... [1]

(c) Estimate the value of

$$\frac{23.1 \times 3.9}{8.12}$$

$$\downarrow \quad \downarrow \quad \approx \quad 20$$

$$\uparrow \quad \uparrow \quad \approx \quad 4 \quad \approx \quad \frac{20 \times 4}{8}$$

$$\downarrow \quad \downarrow \quad \approx \quad 8 \quad = \quad \frac{80}{8}$$

$$= 10$$

(c) ..... **10** ..... [3]

- 8 This is a rule to find the time, in minutes, needed to roast lamb.

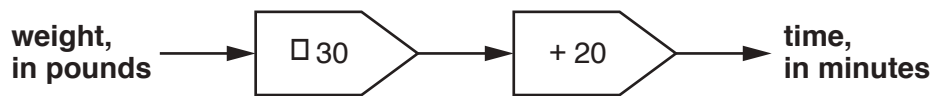

- (a) Use the rule to work out the time needed to roast a piece of lamb which weighs 4 pounds.

$$4 \times 30 = 120$$

$$120 + 20 = 140$$

(a) ..... **140** ..... minutes [2]

- (b) A different piece of lamb takes 95 minutes to roast.

Use the rule to work out the weight of this piece of lamb.

$$95 - 20 = 75$$

$$75 \div 30 = 2.5$$

$$30 \overline{) 75.150} \begin{array}{r} 2.5 \\ \underline{60} \\ 15 \\ \underline{15} \\ 0 \end{array}$$

(b) ..... **2.5** ..... pounds [2]

- 9 The diagram represents a rectangular garden of length 10 m and width 8 m. The flower bed is a triangle and the patio is a trapezium. The rest of the garden is lawn.

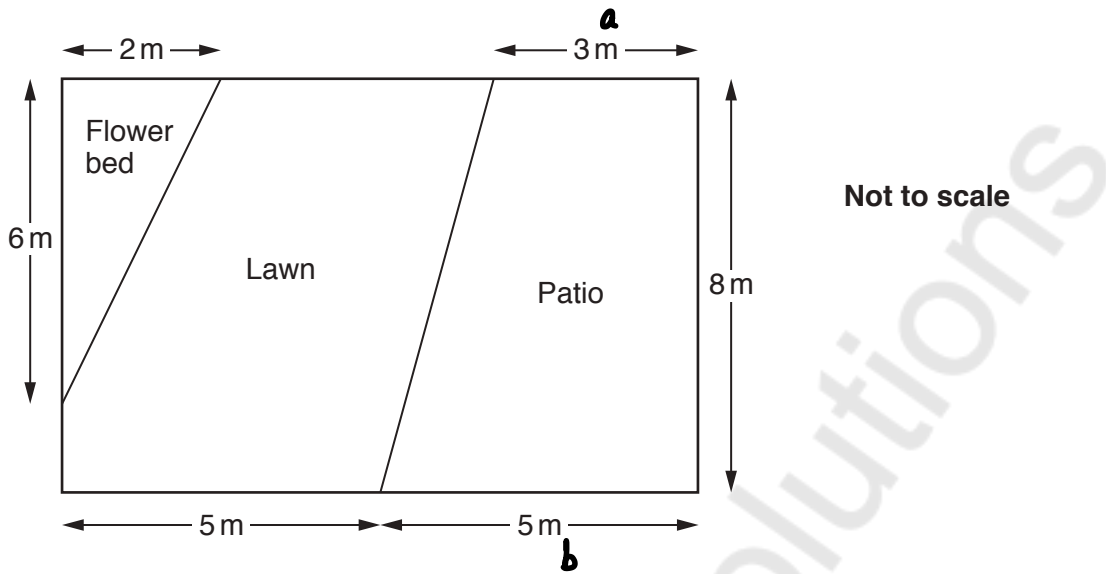

Work out the area of the lawn.

$$\begin{aligned} \text{Area of garden} &= l \times w \\ &= 10 \text{ m} \times 8 \text{ m} \\ &= 80 \text{ m}^2 \end{aligned}$$

$$\begin{aligned} \text{Area of flowerbed} &= \frac{1}{2}bh \\ &= \frac{1}{2} \times 2 \times 6 \\ &= 6 \text{ m}^2 \end{aligned}$$

$$\begin{aligned} \text{Area of patio} &= \frac{1}{2}(a+b) \times h \\ &= \frac{1}{2}(3+5) \times 8 \\ &= 4 \times 8 \\ &= 32 \text{ m}^2 \end{aligned}$$

$$\begin{aligned} \text{Area of Lawn} &= 80 - (6 + 32) \\ &= 80 - 38 \\ &= 42 \text{ m}^2 \end{aligned}$$

..... **42** m<sup>2</sup> [6]

10 This pie chart shows how the employees of a business travel to work.

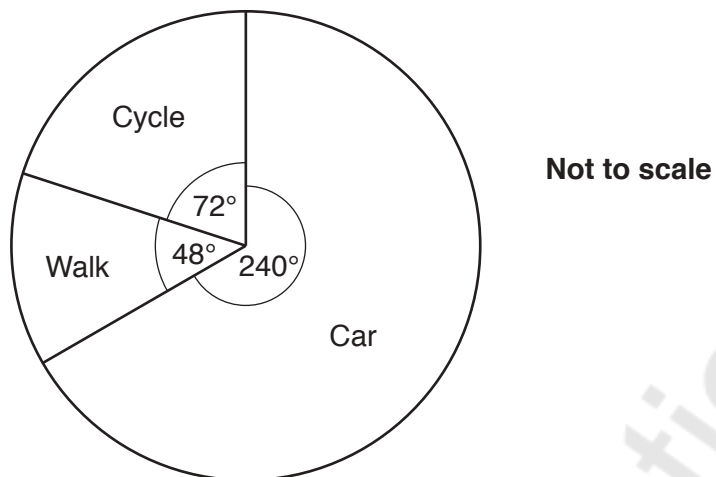

- (a) Find the ratio of the number of employees who cycle to work to the number of employees who walk to work.  
Give your answer in its simplest form.

$$\begin{array}{r}
 \text{Cycle : Walk} \\
 72 : 48 \\
 \div 12 \qquad \qquad \div 12 \\
 6 : 4 \\
 \div 2 \qquad \qquad \div 2 \\
 3 : 2
 \end{array}$$

(a) ..... **3** ..... : ..... **2** ..... [2]

- (b) 80 employees travel to work by car.

Work out the number of employees who cycle to work and the number of employees who walk to work.

$$\begin{array}{r}
 240^\circ = 80 \\
 \quad \quad \quad \curvearrowright \\
 \quad \quad \quad \div 3
 \end{array}$$

$$\text{Cycle } 72^\circ \div 3 = 24$$

$$\text{Walk } 48^\circ \div 3 = 16$$

(b) cycle ..... **24** .....

walk ..... **16** ..... [3]

- 11 (a) Georgia is 4 feet 2 inches tall.  
There are 12 inches in a foot.

Use the conversion, 1 inch = 2.5 centimetres, to convert Georgia's height into metres.

$$\begin{array}{l} 1 \text{ foot} = 12 \text{ inches} \\ \times 4 \qquad \qquad \qquad \times 4 \end{array}$$

$$4 \text{ feet} = 48 \text{ inches}$$

$$48 + 2 = 50 \text{ inches tall}$$

$$\begin{array}{l} 1 \text{ inch} = 2.5 \text{ cm} \\ \qquad \qquad \qquad \curvearrowright \\ \qquad \qquad \qquad \times 2.5 \end{array}$$

$$50 \times 2.5 = 125 \text{ cm}$$

$$125 \div 100 = 1.25 \text{ m}$$

(a) ..... **1.25** ..... m [3]

- (b) Owen weighs 6 stones 4 pounds.  
There are 14 pounds in a stone.

Use the conversion, 2.2 pounds = 1 kilogram, to convert Owen's weight into kilograms.

$$\begin{array}{l} 1 \text{ stone} = 14 \text{ pounds} \\ \times 6 \qquad \qquad \qquad \times 6 \end{array}$$

$$6 \text{ stones} = 84 \text{ pounds}$$

$$84 + 4 = 88 \text{ pounds weight}$$

$$\begin{array}{l} 2.2 \text{ pounds} = 1 \text{ kg} \\ \qquad \qquad \qquad \curvearrowright \\ \qquad \qquad \qquad \div 2.2 \end{array}$$

$$88 \div 2.2$$

$$\equiv \begin{array}{l} \times 10 \qquad \times 10 \\ 880 \div 22 \end{array}$$

$$= 40 \text{ kg}$$

(b) ..... **40** ..... kg [3]

- 12 Jack carries out a survey in his school.  
He selects 50 students, at random, and asks them

Do you think that it is a good idea to have women-only railway carriages?

These are his results.

	Number of students
Yes	32
No	13
Don't know	5

- (a) What percentage of the students in Jack's survey answered 'Yes'?

$$\frac{32}{50} \times 2 = \frac{64}{100} = 64\%$$

(a) ..... **64** % [3]

- (b) Jack says

My survey shows that people in England think that it is a good idea to have women-only railway carriages.

Explain why Jack may be wrong.

..... **Sample size is too small.** .....

..... [1]

- 13 ABCD and PQRS are rectangles.  
O is the centre of both rectangles.

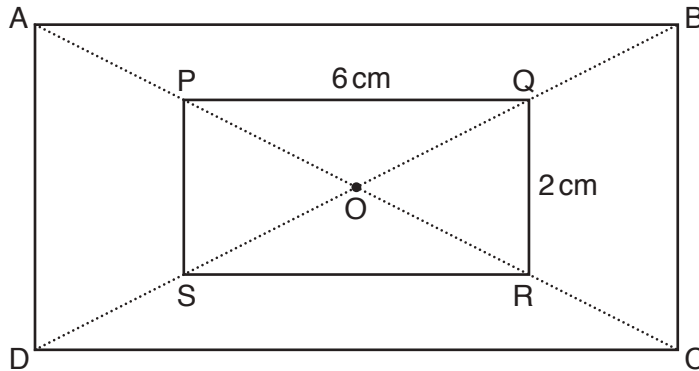

Not to scale

AC is a straight line passing through P, O and R.  
BD is a straight line passing through Q, O and S.

PQ = 6 cm and QR = 2 cm.

The perimeter of rectangle ABCD is 40 cm.

Work out the length and width of rectangle ABCD.

$$\begin{aligned} PQ &: QR \\ 6\text{ cm} &: 2\text{ cm} \\ 3 &: 1 \end{aligned}$$

$$\begin{aligned} AB &: BC \\ 3 &: 1 \end{aligned}$$

$$40\text{ cm} \div 2 = 20\text{ cm}$$

4 parts total

$$20\text{ cm} \div 4 = 5\text{ cm}$$

$$\begin{aligned} AB &= 3 \times 5\text{ cm} \\ &= 15\text{ cm} \end{aligned}$$

$$\begin{aligned} BC &= 1 \times 5 \\ &= 5\text{ cm} \end{aligned}$$

length = 15..... cm

width = 5..... cm [3]

- 14 Halina cycled from A to B at an average speed of 26 km per hour. She then cycled from B to C at an average speed of 20 km per hour.

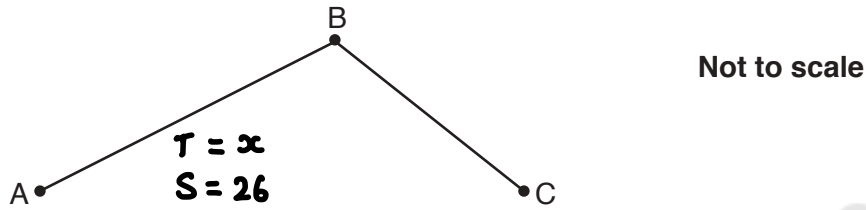

She left A at 10.00 am, did not stop at B and arrived at C at 3.00 pm.

- (a) It took Halina  $x$  hours to cycle from A to B.

- (i) Explain why the distance from A to B, in kilometres, is  $26x$ .

$$D = S \times T \\ = 26 \times x$$

Distance = Speed  $\times$  time  
..... [1]

- (ii) Write down an expression, in terms of  $x$ , for the **time** taken to cycle from B to C.

$$10 \text{ Am} \rightarrow 3 \text{ Pm} = 5 \text{ hours} \quad AB = x \\ 5 - x$$

(a)(ii) .....  $5 - x$  ..... hours [2]

- (iii) Hence show that the **distance** from B to C, in kilometres, is  $100 - 20x$ .

$$S = 20 \text{ km/h} \quad T = 5 - x \quad D = S \times T$$

$20(5 - x) = 100 - 20x$  ..... [1]

- (b) The **total distance** cycled by Halina from A to C is 118 km.

Find the distance from A to B.

$$\text{Distance A to B} = 26x$$

$$\text{Distance B to C} = 100 - 20x$$

$$\text{Total distance} = 26x + 100 - 20x \\ = 100 + 6x$$

$$100 + 6x = 118 \\ -100 \quad -100$$

$$6x = 18 \\ \div 6 \quad \div 6 \\ x = 3$$

(b) ..... **78** ..... km [4]

$$\text{A to B} = 26(3) \\ = 78$$

15 The diagram shows a circle, centre O.

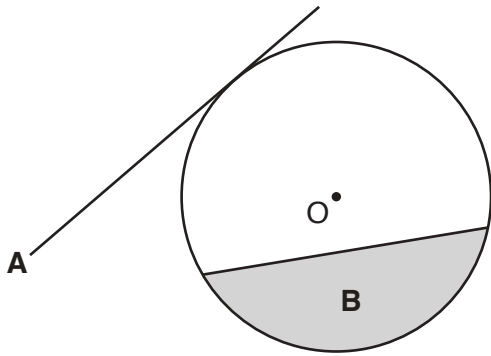

Write down the mathematical name of

(a) line A,

(a) ..... **Tangent** ..... [1]

(b) shaded region B.

(b) ..... **Segment** ..... [1]

16 (a) Write the next term in each of these sequences.

(i) 1      1      2      3      5      8

**5 + 8**

(a)(i) ..... **13** ..... [1]

(ii) 2      4      8      16      32      64

**x 2    x 2    x 2    x 2    x 2    x 2**

(ii) ..... **128** ..... [1]

(b) Write an expression for the  $n$ th term of the sequence below.

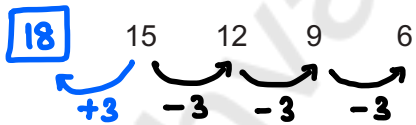

**$-3n + 18$**

(b) .....  **$-3n + 18$**  ..... [2]

17 Andrew is thinking of a number.

- It is between 1 and 150.
- It is one more than a square number.
- It is three less than a cube number.
- It is not a prime number.

What is Andrew's number?

You must show all your reasoning.

Cubes :      1      8      27      64      125      216  
               -3     -2     5      24      61      **122**      215

Squares :    1    4    9    16    25    36    49    64    81    100    121    144  
               +1    2    5    10    17    26    37    50    65    82    101    **122**    145

..... 122 ..... [4]

18 (a) Factorise.

$$\frac{x^2 - 43^2}{\sqrt{\quad} \sqrt{\quad}}$$

$$(x + 43)(x - 43)$$

(a) .....  $(x + 43)(x - 43)$  ..... [1]

(b) Calculate.

$$\frac{57^2 - 43^2}{\sqrt{\quad} \sqrt{\quad}}$$

$$(57 + 43)(57 - 43)$$

$$(100)(14) = 1400$$

(b) ..... 1400 ..... [2]

→ 180°

19 The angles in a triangle are in the ratio 1 : 2 : 3.

(a) Show that the triangle is a right-angled triangle. [2]

$$\begin{array}{l}
 1 : 2 : 3 \quad \text{Total 6 parts} \\
 \downarrow \times 30^\circ \quad 180^\circ \div 6 = 30^\circ \\
 30^\circ : 60^\circ : 90^\circ
 \end{array}$$

(b) The hypotenuse of the triangle is 15 cm long.

Calculate the length of the shortest side in the triangle.

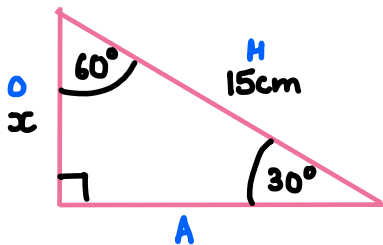

S O H C A H T O A

$$\sin \theta = \frac{O}{H}$$

$$\begin{array}{l}
 \sin 30 = \frac{x}{15} \\
 \times 15 \quad \times 15
 \end{array}$$

$$\begin{array}{l}
 x = 15 \times \sin 30 \\
 = 15 \times \frac{\sqrt{1}}{2} \text{ (b)} \\
 = 15 \times \frac{1}{2}
 \end{array}$$

	0°	30°	45°	60°	90°
Sin	0	1	2	3	4
cos	4	3	2	1	0
					2

..... 7.5 ..... cm [4]

20 There is a total of 250 men, women and children on a train. The ratio of men to women is 4 : 5. The ratio of women to children is 10 : 7.

How many men are on the train?

$$\begin{array}{l}
 m : w \quad w : c \\
 4 : 5 \quad 10 : 7 \\
 \times 2 \quad \times 2 \\
 8 : 10 \quad 10 : 7
 \end{array}$$

$$\begin{array}{l}
 m : w : c \\
 8 : 10 : 7 \\
 \downarrow \times 10 \\
 80
 \end{array}$$

Total 25 parts

250 ÷ 25 = 10 ..... 80 ..... [4]

- 21 (a) Noah starts to draw a tree diagram showing the outcomes of throwing a six when a fair dice is thrown twice.

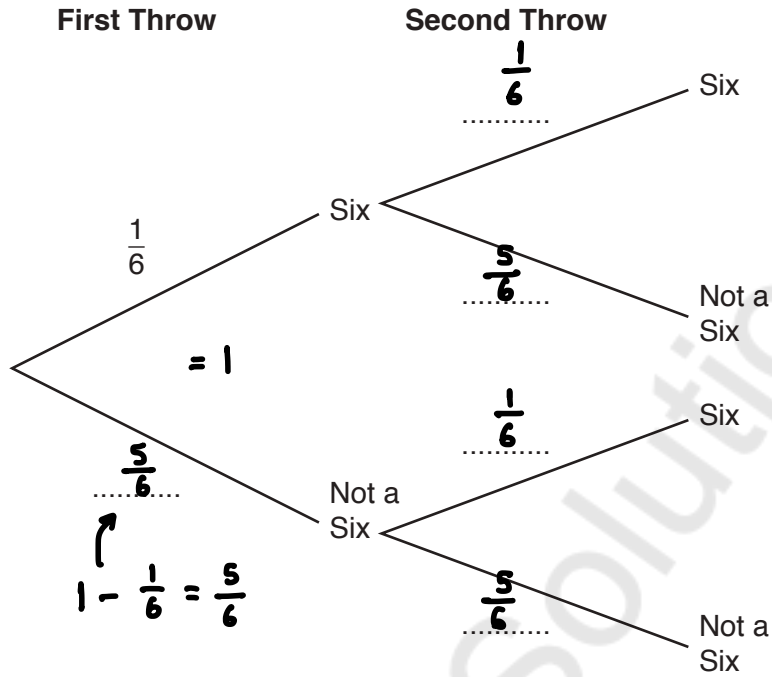

- (i) Complete the tree diagram. [1]

- (ii) What is the probability of throwing two sixes?

$$\frac{1}{6} \times \frac{1}{6} = \frac{1}{36}$$

(a)(ii) .....  $\frac{1}{36}$  ..... [2]

- (b) Cara throws the same dice three times.

Show that the probability that Cara does not throw a six until her third throw is  $\frac{25}{216}$ . [2]

$$\frac{5}{6} \times \frac{5}{6} \times \frac{1}{6} = \frac{25}{216}$$

- 22 (a) Beth is given the following question.

Work out

$$4.1 \times 10^5 \times 3 \times 10^2.$$

Give your answer in standard form.

This is Beth's answer to the question.

$$12.3 \times 10^7$$

Explain why Beth's answer is incorrect.

..... *It is not in standard form.* ..... [1]

- (b) Show that

$$4.5 \times 10^2 + 7.3 \times 10^3 = 7.75 \times 10^3.$$

$$4.5 \times 10^2 = 450$$

$$7.3 \times 10^3 = 7300$$

$$\begin{array}{r} 7300 \\ + 450 \\ \hline 7750 \end{array}$$

$$7750 = 7.75 \times 10^3$$

[2]

$$2n = \text{even}$$

$$\text{Even} + 1 = \text{odd}$$

23 (a)  $n$  is an integer.

(i) Explain why  $2n + 1$  is an odd number.

$2n$  is always even so  $2n + 1$  will be odd.

[1]

(ii) Write down an algebraic expression for the next odd number after  $2n + 1$ .

$$\begin{array}{ccccccc}
 1 & 3 & 5 & 7 & & 2n + 1 + 2 & \\
 +2 & +2 & +2 & & & & 
 \end{array}$$

(a)(ii)  $2n + 3$  [1]

(b) Use algebra to show that the sum of two consecutive odd numbers will always be a multiple of 4. [2]

$$2n + 1, 2n + 3$$

$$\begin{aligned}
 2n + 1 + 2n + 3 &= 4n + 4 \\
 &= 4(n + 1)
 \end{aligned}$$

END OF QUESTION PAPER

