

GCSE (9–1) Mathematics

J560/02 Paper 2 (Foundation Tier)

Thursday 8 November 2018 – Morning

Time allowed: 1 hour 30 minutes



You may use:

- geometrical instruments
- tracing paper

Do not use:

- a calculator



First name										
Last name										
Centre number						Candidate number				

INSTRUCTIONS

- Use black ink. You may use an HB pencil for graphs and diagrams.
- Complete the boxes above with your name, centre number and candidate number.
- Answer **all** the questions.
- Read each question carefully before you start to write your answer.
- Where appropriate, your answers should be supported with working. Marks may be given for a correct method even if the answer is incorrect.
- Write your answer to each question in the space provided. If additional space is required, use the lined page(s) at the end of this booklet. The question number(s) must be clearly shown.
- Do **not** write in the barcodes.

INFORMATION

- The total mark for this paper is **100**.
- The marks for each question are shown in brackets [].
- This document consists of **20** pages.

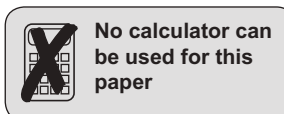

No calculator can be used for this paper

Answer **all** the questions.

1 Here is a hexagon.

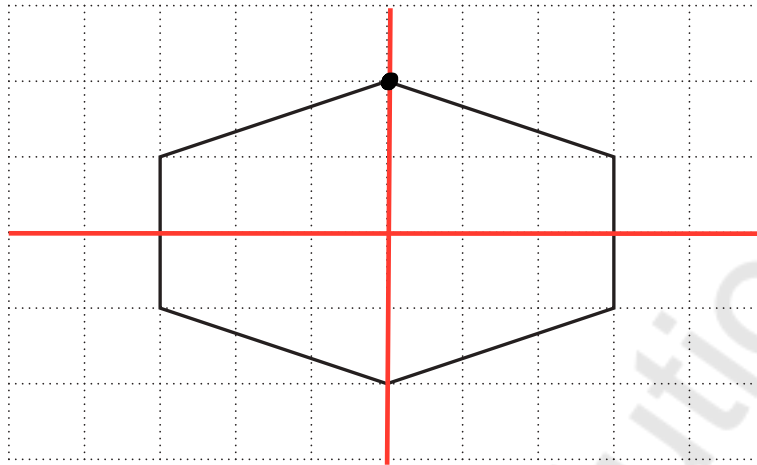

(a) On the diagram, draw the hexagon's two lines of symmetry. [1]

(b) Write down the order of rotation symmetry of the hexagon.

(b) **2** [1]

2 Work out.

(a) $\frac{1}{2}$ of 12

$$12 \div 2 = 6$$

(a) 6 [2]

(b) $8 \times \frac{1}{5}$

Give your answer as a mixed number.

$$\frac{8}{5} = 1 \frac{3}{5}$$

(b) $1 \frac{3}{5}$ [2]

(c) Isaac and Maya eat part of a pizza.

Isaac eats $\frac{1}{6}$ of the pizza.

Maya then eats $\frac{3}{5}$ of the **remaining** pizza.

What fraction of the original pizza is left?

Isaac: $1 - \frac{1}{6}$

$$\frac{6}{6} - \frac{1}{6} = \frac{5}{6}$$

Maya: $\frac{3}{5}$ of $\frac{5}{6}$

$$\frac{3}{5} \times \frac{5}{6} = \frac{15}{30} \stackrel{\div 15}{=} \frac{1}{2}$$

Left

$$\frac{5}{6} - \frac{1}{2}$$

$$\frac{10}{12} - \frac{6}{12} = \frac{4}{12} \stackrel{\div 4}{=} \frac{1}{3}$$

(c) $\frac{1}{3}$ [4]

- 3 (a) Complete the statement using a term from the list.

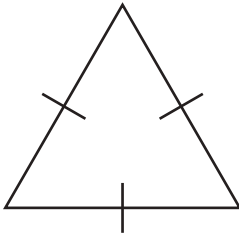

isosceles equilateral right-angled scalene

The triangle is **equilateral**

[1]

- (b) These are the names of some special quadrilaterals.

rectangle parallelogram
trapezium kite rhombus

Choose a quadrilateral from the list that satisfies each set of conditions.

- (i) • All four sides are the same length.
• Opposite angles are equal.

(b)(i) **Rhombus** [1]

- (ii) • All four angles are right angles.
• Opposite sides are equal.

(ii) **Rectangle** [1]

- (c) This is a square based pyramid.

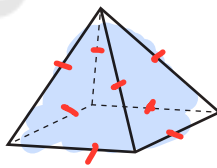

Complete the following.

A square based pyramid has **5** faces and **8** edges.

[2]

4 These are the heights, in metres, of the players in a netball team.

1.30 1.13 ✓ 1.20 ✓ 1.23 ✓ 1.22 ✓ 1.24 ✓ 1.15 ✓

(a) (i) Find the median height of the 7 players.

~~1.13~~ ~~1.15~~ ~~1.20~~ 1.22 ~~1.23~~ ~~1.24~~ ~~1.30~~

(a)(i) **1.22** m [2]

(ii) Work out the range of the heights of the 7 players.

$$\begin{array}{r} 1.20 \\ - 1.13 \\ \hline 0.17 \end{array}$$

(ii) **0.17** m [2]

(iii) The sum of the heights of the 7 players is 8.47 m.

Calculate the mean height of the 7 players.

$$\begin{array}{r} 8.47 \div 7 \\ \hline 1.21 \\ 7 \overline{) 8.47} \end{array}$$

(iii) **1.21** m [2]

(b) The tallest player is replaced by a substitute.

The median height of the players is unchanged. = **1.22**

The mean height of the players becomes smaller.

Write down a possible height for the substitute.

Between 1.22 and 1.30

(b) **1.28** m [2]

5 This graph shows the cost of buying potatoes from a farm.

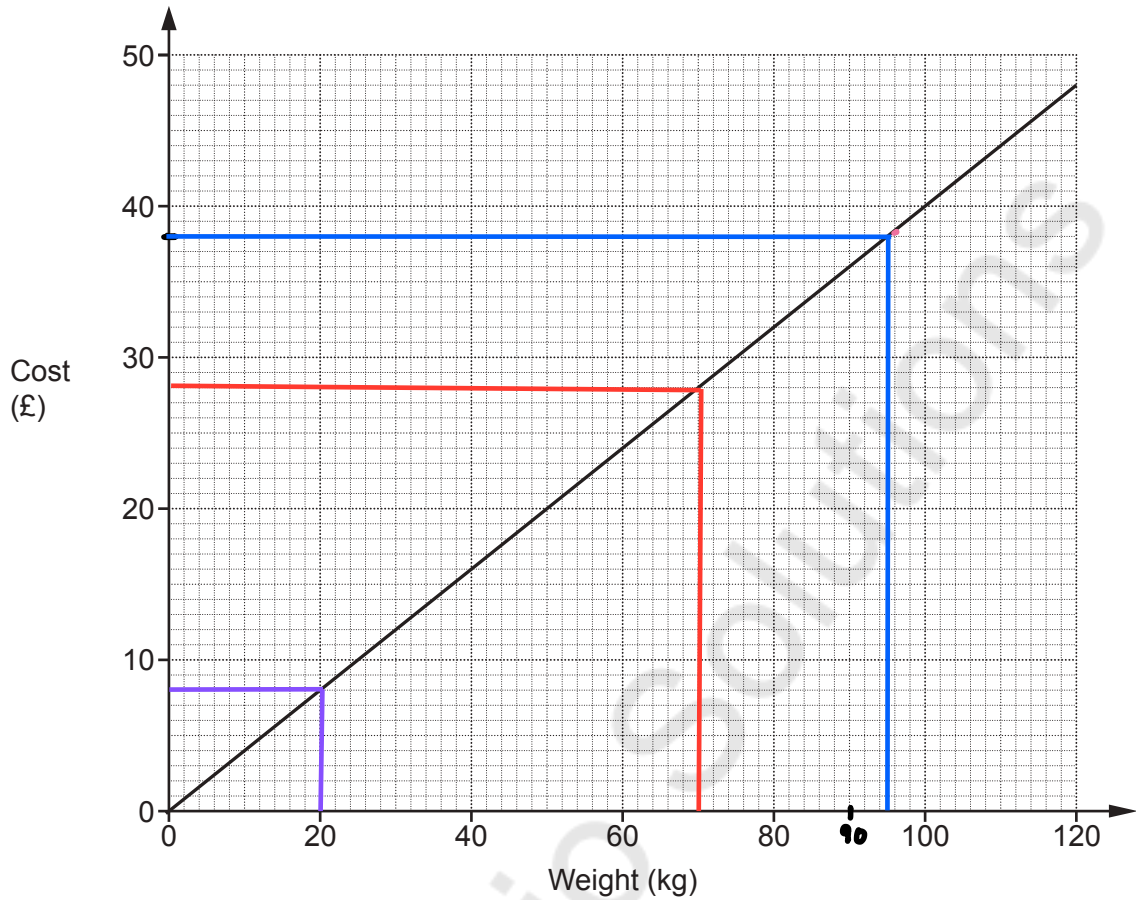

(a) (i) How much does it cost to buy 70 kg of potatoes?

(a)(i) £ 28 [1]

(ii) What weight of potatoes can be bought for £38?

(ii) 95 kg [1]

(iii) The cost per kilogram of potatoes is the same for any weight of potatoes.

How much will it cost to buy 180 kg of potatoes from the farm?

$$\begin{array}{r} 20 \text{ kg} = \text{£}8 \\ \times 9 \qquad \qquad \qquad \times 9 \\ \hline 180 \text{ kg} = \text{£}72 \end{array}$$

(iii) £ 72 [3]

- (b) This graph shows the annual profits, in thousands of pounds, of the farm between 2013 and 2017.

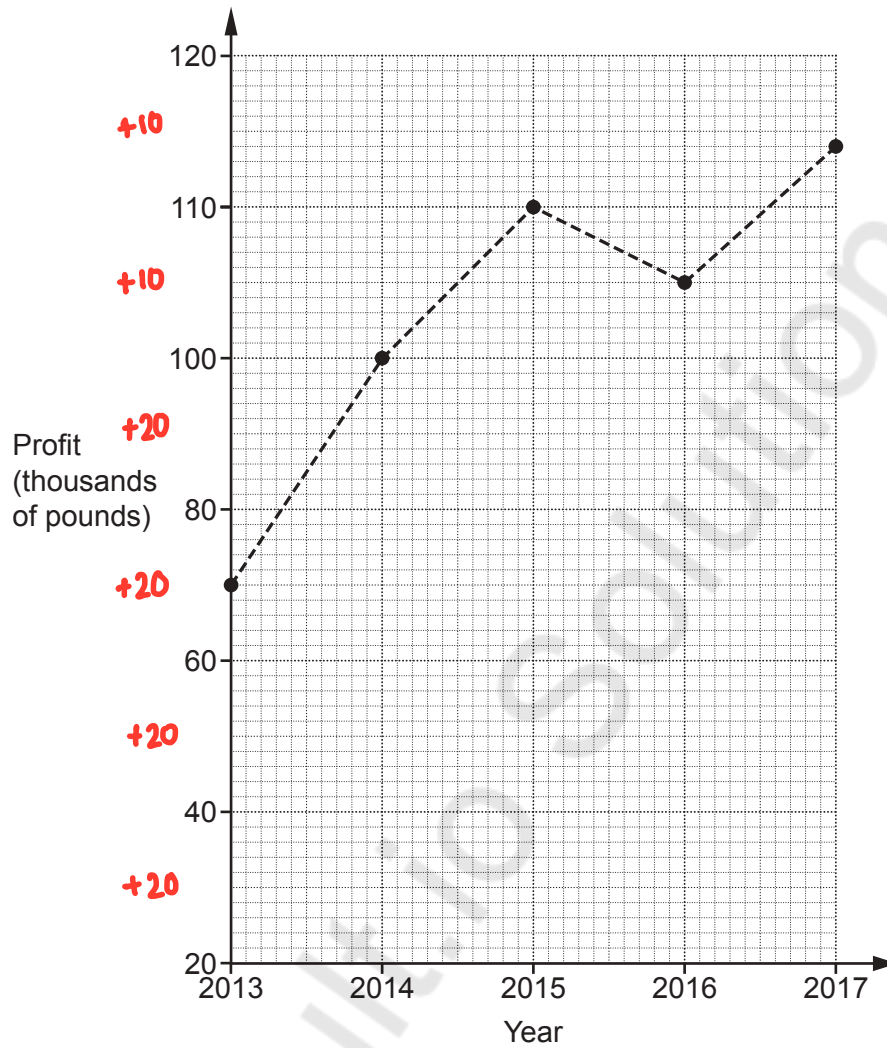

Describe one misleading feature of the graph.

..... Vertical scale is not linear.....
 [1]

- 6 Which is bigger, 36% or $\frac{7}{20}$?

Show your working and give a reason for your answer.

$$\frac{7}{20} \begin{matrix} \times 5 \\ \\ \times 5 \end{matrix} = \frac{35}{100} = 35\%$$

..... **36%**..... is bigger because **36%**..... > **35%**.....

..... [4]

- 7 (a) Write down the value of $\sqrt[3]{27}$.

$$3 \times 3 \times 3 = 27$$

(a) **3** [1]

- (b) Work out 7^2 .

$$7 \times 7 = 49$$

(b) **49** [2]

- (c) Write 6^{-1} as a fraction.

$$x^{-a} = \frac{1}{x^a}$$

$$6^{-1} = \frac{1}{6^1} = \frac{1}{6}$$

(c) **$\frac{1}{6}$** [1]

- 8 A water company charged the following in 2017.

£2.00 for each m^3 of water used
plus
a fixed charge of £45

In 2017 Jenny used 110m^3 of water.

For the 12 months of 2017 she paid £20 per month to the water company.

How much more money does Jenny need to pay to the water company?

$$\text{£}2 \times 110\text{m}^3 = \text{£}220$$

$$\text{£}220 + \text{£}45 = \text{£}265 \quad [\text{owes}]$$

$$12 \times \text{£}20 = \text{£}240 \quad [\text{paid}]$$

$$\text{£}265 - \text{£}240 = \text{£}25 \quad [\text{left to pay}]$$

£ 25 [6]

- 9 (a) Rearrange this formula to make x the subject.

$$\begin{array}{r} y = x - 2 \\ +2 \quad +2 \\ \hline y + 2 = x \end{array}$$

(a) $x = y + 2$ [1]

- (b) Rearrange this formula to make d the subject.

$$\begin{array}{r} C = \pi d \\ \div \pi \quad \div \pi \\ \hline \frac{C}{\pi} = d \end{array}$$

(b) $d = \frac{C}{\pi}$ [1]

10 (a) Write down the equation of each of these lines.

(i)

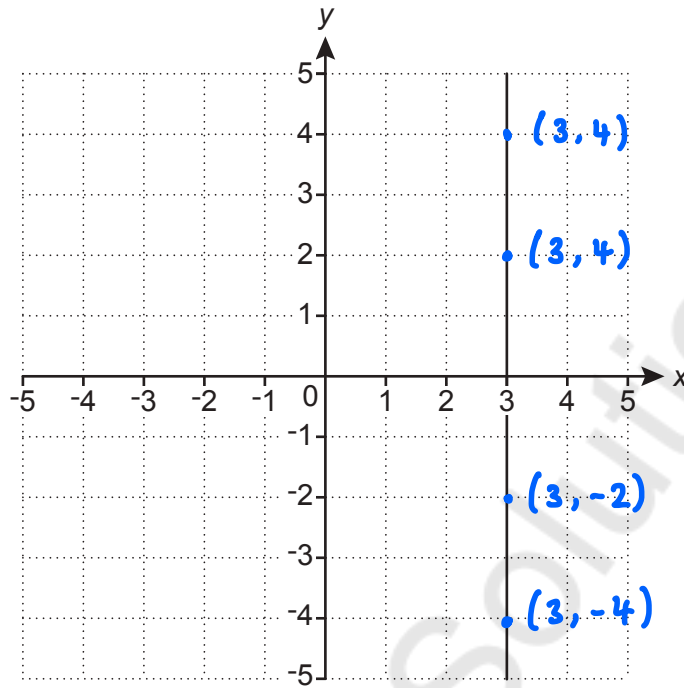

(a)(i) $x = 3$ [1]

(ii)

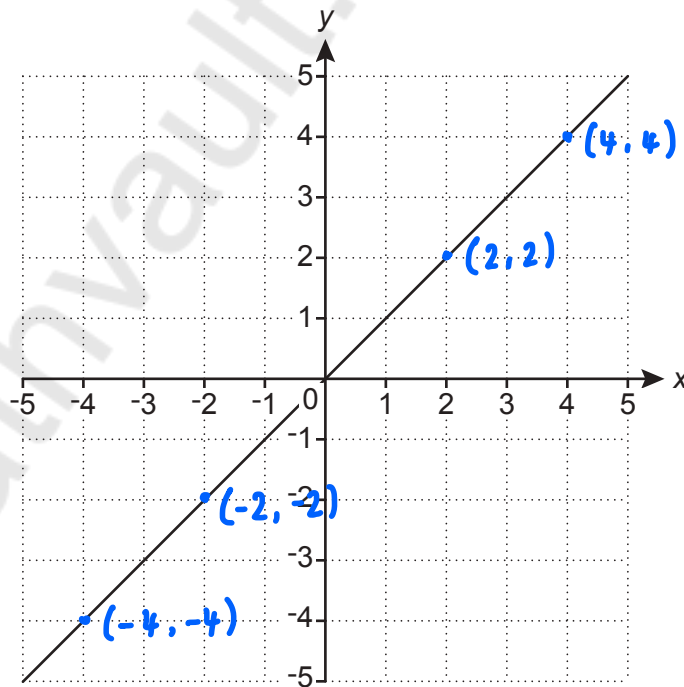

(ii) $y = x$ [1]

(b) Sketch the graph of $y = x^2$.

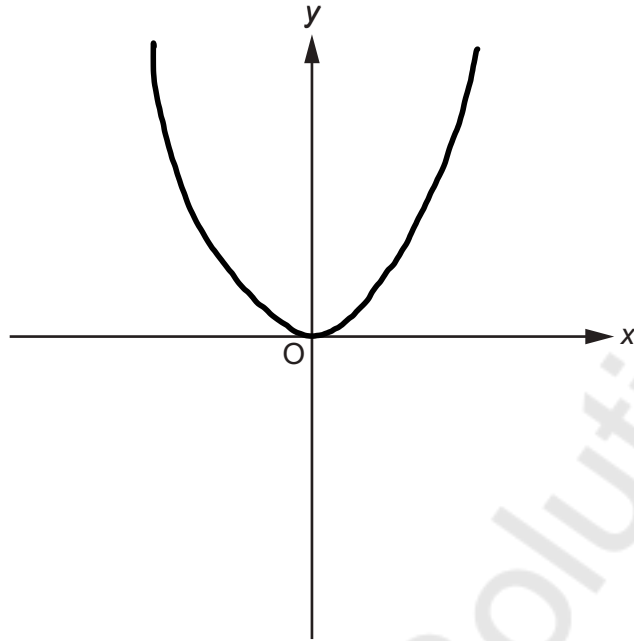

[1]

11 Some biscuits contain only three ingredients: flour, butter and sugar.

- The ratio of flour to butter is 5 : 4.
- The ratio of butter to sugar is 2 : 1.
- The total weight of the flour, butter and sugar is 770g.

Work out the weight of each of the ingredients.

$$\begin{array}{l} \mathbf{F : B} \\ \mathbf{5 : 4} \end{array} \quad \begin{array}{l} \mathbf{B : S} \\ \mathbf{2 : 1} \\ \mathbf{\times 2 \quad \times 2} \\ \mathbf{4 : 2} \end{array}$$

$$\begin{array}{l} \mathbf{F : B : S} \\ \mathbf{5 : 4 : 2} \end{array} \quad \begin{array}{l} \mathbf{Total\ parts = 11} \\ \mathbf{770 \div 11 = 70} \end{array}$$

$$\mathbf{F = 5 \times 70 = 350g}$$

$$\mathbf{B = 4 \times 70 = 280g}$$

$$\mathbf{S = 2 \times 70 = 140g}$$

$$\text{Flour} \dots \mathbf{350} \dots \text{g}$$

$$\text{Butter} \dots \mathbf{280} \dots \text{g}$$

$$\text{Sugar} \dots \mathbf{140} \dots \text{g [4]}$$

12 (a) Work out.

$$\begin{array}{l} 8 \div 0.4 \\ \mathbf{\times 10 \quad \times 10} \\ \mathbf{80 \div 4 = 20} \end{array}$$

$$\text{(a) } \dots \mathbf{20} \dots \text{ [2]}$$

(b) By writing each number correct to 1 significant figure, find an estimate for this calculation.

$$\begin{array}{l} \mathbf{22.1 \approx 20} \\ \mathbf{3.7 \approx 4} \\ \mathbf{1.9 \approx 2} \end{array} \quad \begin{array}{l} \mathbf{20 \times 40} \\ \mathbf{\hline 2} \\ \mathbf{= \frac{800}{2}} \\ \mathbf{= 400} \end{array}$$

$$\text{(b) } \dots \mathbf{400} \dots \text{ [3]}$$

15 (a) Multiply out.

$$(3x - 2y)(x + y)$$

Give your answer in its simplest form.

$$3x^2 + 3xy - 2xy - 2y^2$$

$$3x^2 + xy - 2y^2$$

(a) $3x^2 + xy - 2y^2$ [3]

(b) $3(2x + d) + c(x + 5) = 10x + 17$

Work out the value of c and the value of d .

$$6x + 3d + cx + 5c = 10x + 17$$

$$6x + cx = 10x$$

$$-6x \quad -6x$$

$$cx = 4x$$

$$c = 4$$

$$3d + 5c = 17$$

$$3d + 5(4) = 17$$

$$3d + 20 = 17$$

$$-20 \quad -20$$

$$3d = -3$$

$$\div 3 \quad \div 3$$

$$d = -1$$

(b) $c = 4$

$d = -1$ [5]

(c) Solve by factorising.

$$x^2 - 7x + 10 = 0$$

$$\underline{-2} \times \underline{-5} = 10$$

$$\underline{-2} + \underline{-5} = -7$$

$$\begin{array}{r} 10 \\ 1 \quad 10 \\ \hline -2 \quad -5 \end{array}$$

$$(x - 2)(x - 5) = 0$$

$$x - 2 = 0 \quad \text{or} \quad x - 5 = 0$$

$$+2 \quad +2 \quad \quad \quad +5 \quad +5$$

$$x = 2$$

$$x = 5$$

(c) $x = 2$ or $x = 5$ [3]

16 Geoff has two fair spinners.

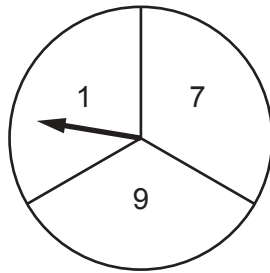

Spinner A

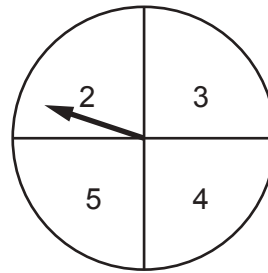

Spinner B

He spins both spinners and **multiplies** the numbers on each spinner.

(a) Complete the table.

		Spinner A		
		1	7	9
Spinner B	2	2	14	18
	3	3	21	27
	4	4	28	36
	5	5	35	45

[1]

(b) Geoff wants to work out the probability that the outcome of the multiplication is an even number or a prime number.

Here is his working.

The probability the outcome is an even number is $\frac{6}{12}$. ✓

The probability the outcome is a prime number is $\frac{3}{12}$. ✓

The probability the outcome is an even number or a prime number is $\frac{6}{12} + \frac{3}{12} = \frac{9}{12}$.

Geoff is wrong.

Explain his error and give the correct answer.

Even and prime are not mutually exclusive so probability should be $\frac{8}{12}$. [2]

- 17 The depth of water in a garden pond is 57.8 cm.
The depth decreases by 0.3 cm per day.

(a) Assume the depth continues to decrease at the same rate.

After how many days will the depth reach 54.2 cm?

$$\begin{array}{r} 57.8 \\ - 54.2 \\ \hline 03.6 \end{array}$$

$$\begin{array}{r} 3.6 \div 0.3 \\ \times 10 \quad \times 10 \end{array}$$

$$36 \div 3 = 12 \text{ days}$$

(a) **12** days [3]

- (b) If the depth of water decreases at a slower rate, what effect will this have on your answer to part (a)?

..... **Answer would be bigger.** [1]

- 18 Emily spent £2400 on holiday in 2017.
This was 20% more than she spent on holiday in 2016.

Calculate the amount she spent on holiday in 2016.

$$2016 = 100\%$$

$$2017 = 120\% = 2400$$

$$\begin{array}{r} 120\% = 2400 \\ \div 12 \quad \div 12 \\ 10\% = 200 \\ \times 10 \quad \times 10 \\ 100\% = 2000 \end{array}$$

£ **2000** [3]

19 Triangle A and triangle B are drawn on the coordinate grid.

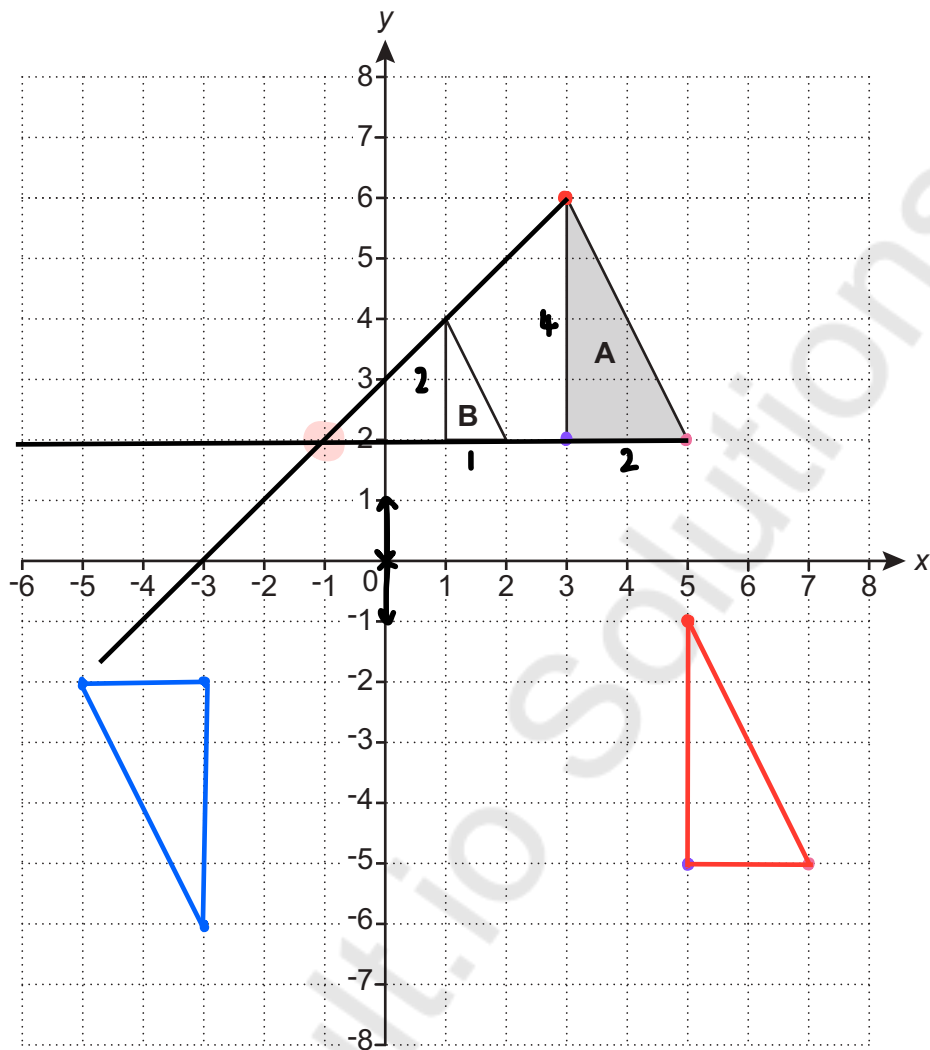

(a) (i) Draw the image of triangle A after a rotation of 180° about $(0, 0)$. [2]

(ii) Draw the image of triangle A after a translation by the vector $\begin{pmatrix} 2 \\ -7 \end{pmatrix}$. $\begin{matrix} 2 \text{ right} \\ 7 \text{ down} \end{matrix}$ [2]

(b) Describe fully the **single** transformation that maps triangle A onto triangle B.

..... Enlargement by scale factor $\frac{1}{2}$, centre $(-1, 2)$

[3]

20 The table shows the number of computers sold in Tom's shop each quarter from 2015 to 2017.

	2015				2016				2017			
Quarter	1	2	3	4	1	2	3	4	1	2	3	4
Number of computers sold	13	31	29	45	20	32	25	47	27	40	30	58

(a) Complete this graph using the information for 2017.

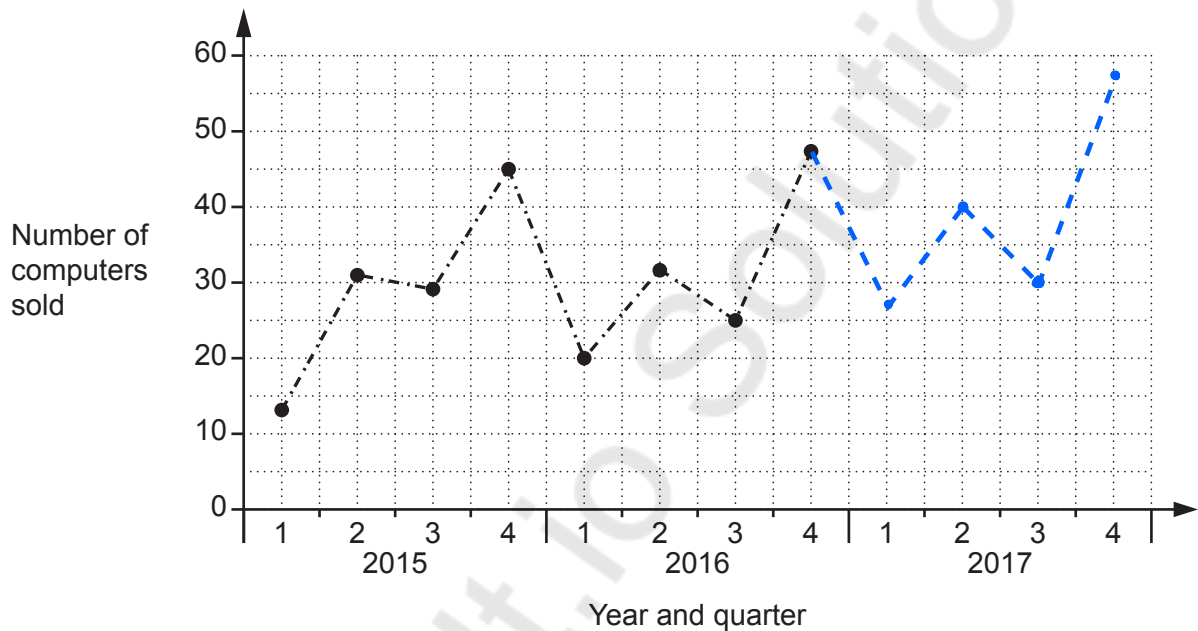

[2]

(b) Tom adds the three results for quarter 1 and he adds the three results for quarter 4.
Tom says

The ratio of the **total** number of computers sold in quarter 1 compared to quarter 4 is 2 : 5.

Is he correct?
Show your reasoning.

Q1

$$13 + 20 + 27$$

$$33 + 27$$

$$= 60$$

Q4

$$45 + 47 + 58$$

$$92 + 58$$

$$= 150$$

Q1 : Q4

$$60 : 150$$

$$\div 30 \quad \div 30$$

$$2 : 5$$

Yes

[2]

- (c) Make two comments about Tom's sales over the period 2015 to 2017.

Comment 1 Number of computers sold increased

.....

Comment 2 More computers sold in Q4 than Q1

..... [2]

- (d) Tom predicts that he will sell more than 60 computers in the 4th quarter of 2018.

What assumption has he made?

..... Increasing trend continues

..... [1]

- 21 A circle, with centre O and radius 6 cm, contains another circle, with centre O and radius x cm.

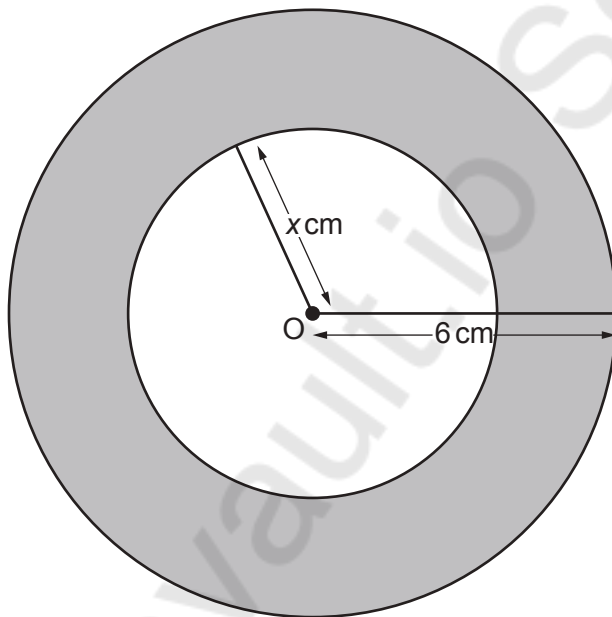

Not to scale

$$\text{Area of circle} = \pi r^2$$

Write down an expression, in terms of π and x , for the shaded area in cm^2 .

Larger circle area

$$= \pi \times 6^2$$

$$= \pi \times 36$$

$$= 36\pi$$

Smaller circle area

$$= \pi \times x^2$$

$$= \pi x^2$$

$$\text{Shaded area} = 36\pi - \pi x^2$$

$$\text{..... } 36\pi - \pi x^2 \text{ [2]}$$

END OF QUESTION PAPER

