

Thursday 4 November 2021 – Morning

GCSE (9–1) Mathematics

J560/02 Paper 2 (Foundation Tier)

Time allowed: 1 hour 30 minutes



You can use:

- geometrical instruments
- tracing paper

Do not use:

- a calculator



Please write clearly in black ink. **Do not write in the barcodes.**

Centre number

--	--	--	--	--

Candidate number

--	--	--	--

First name(s)

Last name

INSTRUCTIONS

- Use black ink. You can use an HB pencil, but only for graphs and diagrams.
- Write your answer to each question in the space provided. If you need extra space, use the lined pages at the end of this booklet. The question numbers must be clearly shown.
- Answer **all** the questions.
- Where appropriate, your answer should be supported with working. Marks might be given for using a correct method, even if your answer is wrong.

INFORMATION

- The total mark for this paper is **100**.
- The marks for each question are shown in brackets [].
- This document has **20** pages.

ADVICE

- Read each question carefully before you start your answer.

Answer **all** the questions.

- 1 (a) How many sides does a pentagon have?



(a) **5** [1]

- (b) Write down the mathematical name of this solid.

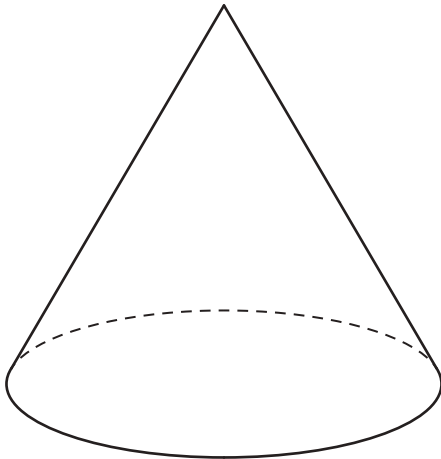

(b) **Cone** [1]

- (c) The angles in a triangle are 40° , 50° and 90° .

Write down the mathematical name for this type of triangle.

(c) **Right-angled triangle** [1]

- 2 Work out.

- (a) $-7 + 10$

$$10 - 7 = 3$$

(a) **3** [1]

- (b) 4×-2

$$4 \times 2 = 8$$

$$4 \times -2 = -8$$

(b) **-8** [1]

3 Work out.

(a) $9.06 \div 3$

$$\begin{array}{r} 3.02 \\ 3 \overline{) 9.06} \end{array}$$

(a) **3.02** [1]

(b) 15×0.6

$$\begin{array}{r} \downarrow \times 10 \\ 15 \times 6 \\ \hline 90 \end{array} \xrightarrow{\div 10} 9$$

(b) **9** [2]

4 Use one of these symbols $<$, $>$ or $=$ to make each statement true.

(a) $\frac{1}{4}$ **0.25** $>$ 0.025 [1]

(b) 0.304 $<$ 0.34 [1]

5 (a) Work out.

$$4 + 16 \div 2$$

BIDMAS

$$16 \div 2 = 8$$

$$4 + 8 = 12$$

(a) **12** [1]

(b) Insert one pair of brackets to make the calculation correct.

$$36 \div 9 = 4$$

$(5 \times 7 + 1) \div 9 = 4$ [1]

6 In a quiz, Darcy answered 16 of the 20 questions correctly.

- (a) What fraction of the questions did Darcy answer correctly?
Give your fraction in its lowest terms.

$$\frac{16}{20} \begin{array}{l} \div 4 \\ = \\ \div 4 \end{array} = \frac{4}{5}$$

(a) $\frac{4}{5}$ [2]

- (b) Write the fraction as a decimal.

$$\frac{4}{5} \begin{array}{l} \times 2 \\ = \\ \times 2 \end{array} = \frac{8}{10} \quad 8 \div 10 = 0.8$$

(b) 0.8 [1]

- 7 (a) Write $\frac{13}{3}$ as a mixed number.

$$4 \frac{1}{3}$$

(a) $4 \frac{1}{3}$ [1]

- (b) Work out.

(i) $\frac{1}{3} + \frac{4}{9}$

$$\frac{1}{3} \begin{array}{l} \times 3 \\ \times 3 \end{array} = \frac{3}{9}$$

$$\frac{3}{9} + \frac{4}{9} = \frac{7}{9}$$

(b)(i) $\frac{7}{9}$ [2]

(ii) $3 \div \frac{1}{3}$

$$3 \times \frac{3}{1}$$

$$3 \times 3 = 9$$

(ii) 9 [1]

8 Here is a function.

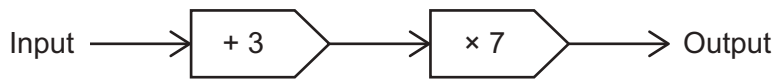

(a) Find the output when the input is 2.

$$2 + 3 = 5$$

$$5 \times 7 = 35$$

(a) **35** [1]

(b) Find the input when the output is 63.

$$63 \div 7 = 9$$

$$9 - 3 = 6$$

(b) **6** [2]

9 A shopper buys 4 apples costing 60p each and 3 peaches. They pay with a £5 note and receive 44p in change. Each peach costs the same amount.

Work out the cost of one peach. You must show your working.

Apples $60 \times 4 = 240\text{p}$ or $\pounds 2.40$

Spent $\pounds 5 = 500\text{p}$

$$\begin{array}{r} 490 \\ - 44 \\ \hline 456 \end{array}$$

$$500 - 44 = 456\text{p} \text{ or } \pounds 4.56$$

3 peaches $\begin{array}{r} 456 \\ - 240 \\ \hline 216\text{p} \end{array}$

1 peach $\begin{array}{r} 072 \\ 3 \overline{) 216} \\ \hline = 72\text{p} \end{array}$

..... **72** p [5]

- 10 Ben and Sundip are making pancakes using the ingredients below.

<p>Ingredients to make 12 pancakes</p> <p>75ml water 200ml milk 100g flour 50g butter 2 eggs</p>
--

- (a) The ratio of the amount of water to the amount of milk needed is 75 : 200.

Write this ratio in its simplest form.

$$\begin{array}{r} 15 \\ 5 \overline{) 75} \\ \underline{50} \\ 25 \end{array} \qquad \begin{array}{r} 040 \\ 5 \overline{) 200} \\ \underline{200} \\ 0 \end{array}$$

$$15 : 40$$

$$3 : 8$$

(a) 3 : 8 [2]

- (b) Ben makes 18 pancakes.

Work out how much flour he needs.

$$12 \div 2 = 6 \quad \times 3 = 18$$

$$100\text{g} \div 2 = 50\text{g} \quad \times 3 = 150\text{g}$$

(b) 150 g [2]

- (c) Sundip has 225g of butter and 10 eggs.
She has plenty of the other ingredients.

Work out the maximum number of pancakes that she can make.

Butter $225 \div 50 = 4.5$

$$\begin{array}{r} 4.5 \\ 50 \overline{) 225.250} \\ \underline{200} \\ 250 \\ \underline{250} \\ 0 \end{array}$$

Eggs $10 \div 2 = 5$

$$\begin{array}{r} 12 \times 4.5 \\ \begin{array}{r} 112 \\ \times 45 \\ \hline 60 \\ 480 \\ \hline 540 \end{array} \times 10 \\ \hline 5400 \div 10 = 540 \end{array}$$

(c) 54 [4]

- 11 Ali (A), Blake (B), Rowan (R) and Sam (S) are in a relay team.
Sam always runs fourth in the team.
The order for the other three is chosen at random.

- (a) Complete this table to show all the possible orders for the team.
The first row has been completed for you.
You may not need to use all the rows.

First	Second	Third	Fourth
A	B	R	S
A	R	B	S
B	A	R	S
B	R	A	S
R	B	A	S
R	A	B	S

[2]

- (b) Find the probability that Ali will run first.

(b) $\frac{2}{6}$

[2]

- 12 The shape below is formed by a rectangle of width 4 cm and a regular pentagon. For the rectangle, the ratio of the width to the length is 2 : 5.

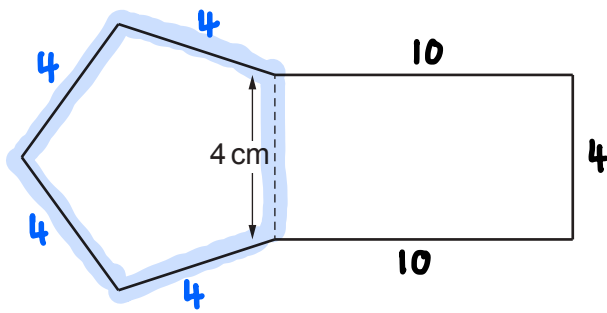

Not to scale

Work out the perimeter of the shape.

$$\begin{array}{l} W : L \\ 2 : 5 \\ \times 2 \quad \times 2 \\ 4 : 10 \end{array}$$

$$\begin{aligned} \text{Perimeter} &= 4 + 4 + 4 + 4 + 10 + 10 + 4 \\ &= 40 \text{ cm} \end{aligned}$$

..... **40** cm [4]

- 13 (a) Reece is given this question.

Write 20 as a product of prime factors.
Give your answer in index form.

Reece's answer is $2 \times 2 \times 5$.

Is Reece correct?
Explain your answer.

..... **No., it should be $2^2 \times 5$** [1]

- (b) Complete the power of 2.

$$\frac{1}{8} = 2^{\boxed{-3}} \quad [1]$$

- (c) Work out.

$$\sqrt{81} \times 2^3$$

$$\pm 9 \times 8$$

$$9 \times 8 = 72$$

$$-9 \times 8 = -72$$

(c) **± 72** [3]

- 14 A car mechanic has a tin containing 5 litres of engine oil.
Each week they use 450 millilitres of this oil for their vehicles.

The car mechanic says

After 9 weeks I will have used over 80% of the oil in this tin.

Are they correct?

Show how you decide.

$$1\text{ L} = 1000\text{ ml}$$

↘
x1000

$$5\text{ L} = 5000\text{ ml}$$

$$\begin{array}{r} 450 \\ \times 9 \\ \hline 4050 \text{ ml} \end{array}$$

$$\begin{array}{l} 10\% \text{ of } 5000\text{ ml} = 500\text{ ml} \\ 80\% \text{ of } 5000\text{ ml} = 4000\text{ ml} \end{array} \quad \times 8$$

$$4050\text{ ml} > 4000\text{ ml}$$

Yes.

[5]

15 Solve the inequality.

$$2(x+5) < 16$$

$$\div 2 \quad \div 2$$

$$x + 5 < 8$$

$$- 5 \quad - 5$$

$$x < 3$$

$$x < 3$$

[3]

16 Here are sketches of five graphs.

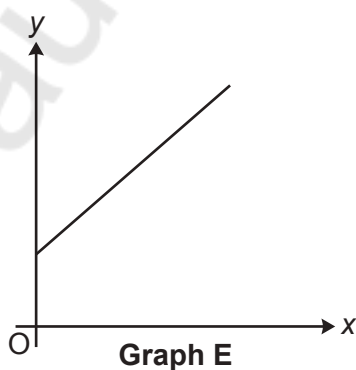
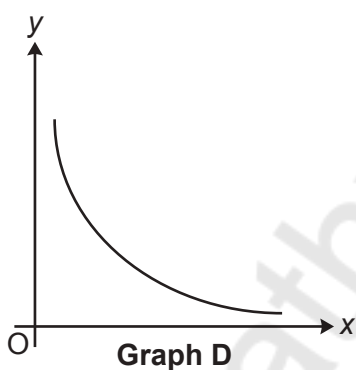
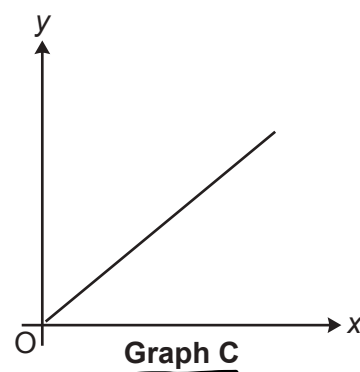
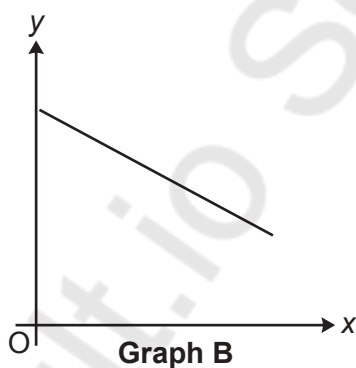
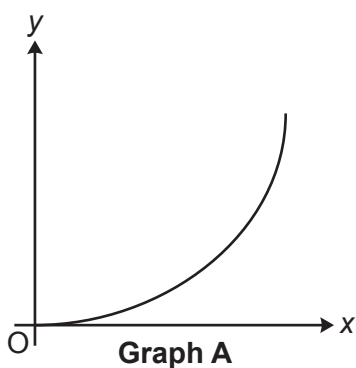

Write the letter of the graph that represents the following relationships.

(a) y is directly proportional to x .

Straight line, (0,0)

(a) **C** [1]

(b) y is inversely proportional to x .

Non-linear, reciprocal

(b) **D** [1]

17 The diagram shows a prism.

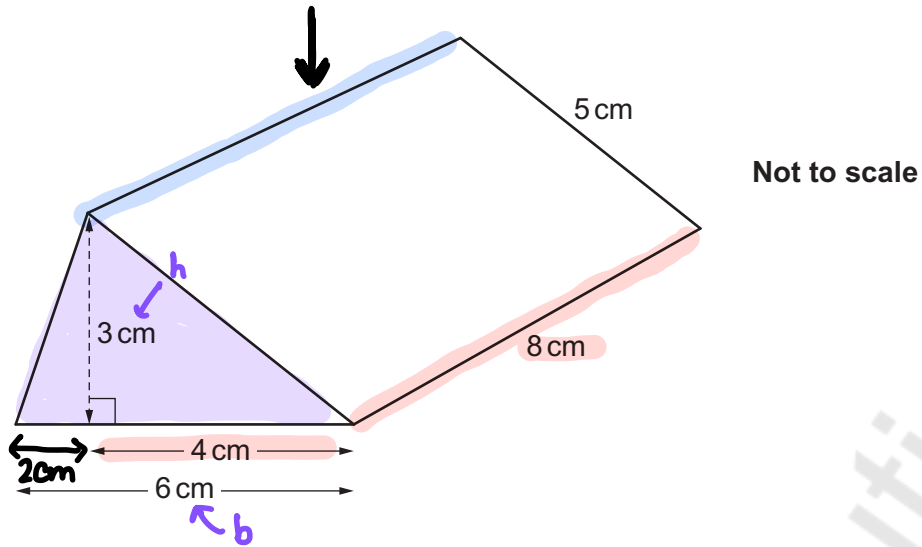

(a) Draw an accurate plan view of the prism on the one-centimetre square grid below.

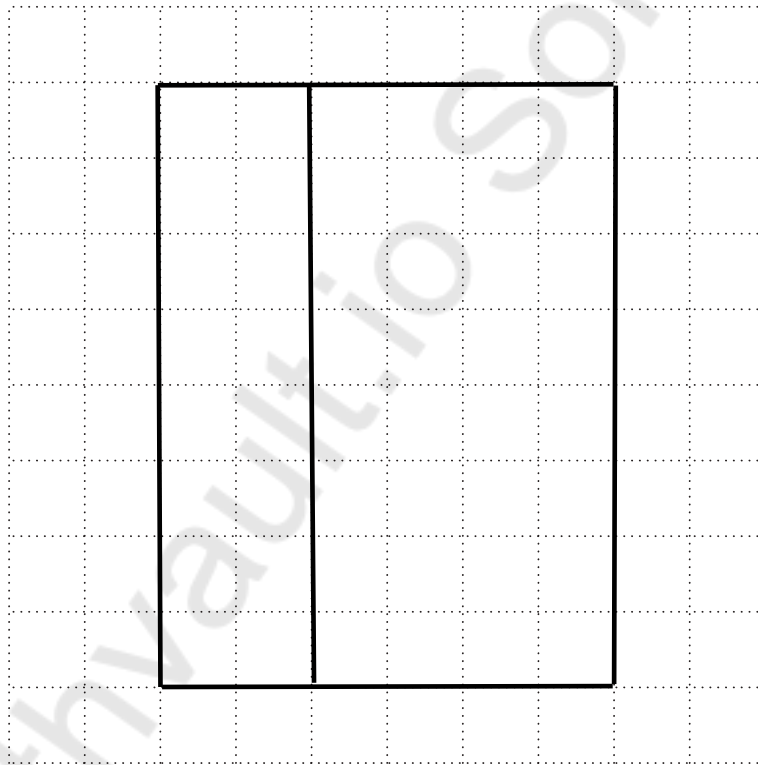

[3]

(b) Show that the volume of the prism is 72 cm^3 .

[2]

$$\begin{aligned} \text{Vol} &= \text{area of cross-section} \times \text{length} \\ &= \frac{1}{2} \times 6 \times 3 \times 8 \\ &= 9 \times 8 \\ &= 72 \text{ cm}^3 \end{aligned}$$

(c) A cuboid with a square base also has a volume of 72 cm^3 .
The height of the cuboid is 2 cm.

Work out the length of one side of the square base.

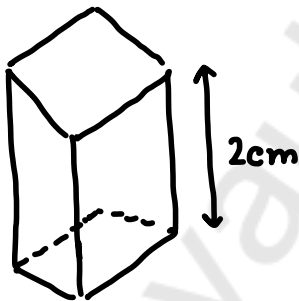

$$\begin{aligned} \text{Vol} &= l \times w \times h \\ 72 &= l \times w \times 2 \\ \div 2 & \qquad \qquad \div 2 \\ 36 &= l \times w \\ \sqrt{36} &= 6 \\ l = 6 & \quad w = 6 \end{aligned}$$

(c) **6** cm [3]

Turn over

18 The table shows the marks obtained by 10 students in spelling tests in January and February.

Mark in January	26	53	50	48	30	66	70	44	37	38
Mark in February	42	58	68	58	66	82	86	60	48	50

The marks for the first six students are plotted on the scatter diagram.

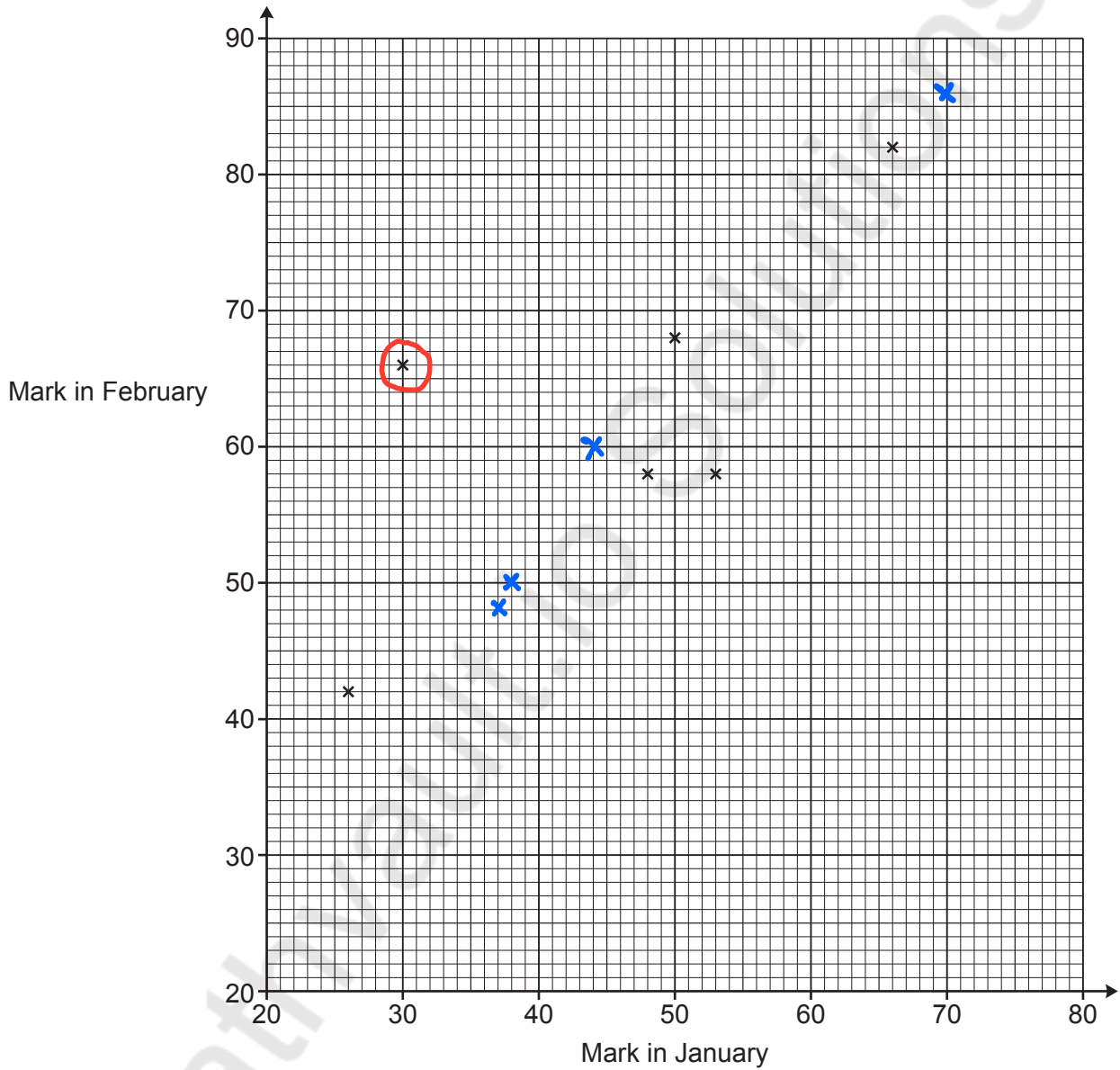

(a) Plot the marks for the remaining four students. [2]

(b) Describe the type of correlation shown in the completed scatter diagram.

Positive

..... [1]

- (c) (i) On the scatter diagram, **circle** the student that made the greatest improvement in their marks from January to February. [1]
- (ii) Work out the percentage change in this student's marks from January to February.

$$\text{January} = 30$$

$$\text{February} = 66$$

$$\frac{\text{change}}{\text{original}} \times 100$$

$$\frac{66 - 30}{30} \times 100$$

$$\frac{36}{30} \times 100$$

$$\frac{12}{10} \times 100 = 1.2 \times 100$$

(c)(ii) **120** % [3]

- (d) Another student, Kai, scored 79 marks in the test in January but was absent for the test in February.

Kai says

I could use a line of best fit on the scatter diagram to estimate the marks I may have achieved in the test in February.

Is Kai's method reliable?

Give a reason for your answer.

..... **No., 79 is outside the range of data.**

..... [1]

- 19 A worker received a 10% pay increase in 2017 and a further 10% pay increase in 2018. The worker says

Over these two years, my pay increased by $10\% + 10\% = 20\%$.

The worker is incorrect.

Work out the correct percentage increase.

You must show your working.

2017

$$100\% + 10\% = 110\% \xrightarrow{\div 100} 1.1$$

2018

1.1

$$\begin{array}{r} 1.1 \\ \times 10 \\ \hline 11 \end{array} \times \begin{array}{r} 1.1 \\ \times 10 \\ \hline 11 \end{array} = 121 \xrightarrow{\div 100} 1.21$$

21% increase

[5]

- 20 Force is measured in newtons (N).
A force of 198.5 N is applied to a rectangular surface of length 4.9 cm and width 4.1 cm.

Work out an **estimate** of the pressure, in N/cm^2 , applied to this rectangular surface.

[The formula for pressure is: $\text{Pressure} = \frac{\text{Force}}{\text{Area}}$]

$$\text{Force} = 198.5 \approx 200 \text{ N}$$

$$\begin{aligned} \text{Area} &= l \times w \\ &= 4.9 \times 4.1 \\ &\approx 5 \times 4 \\ &= 20 \text{ cm}^2 \end{aligned}$$

$$\text{Pressure} = \frac{200 \text{ N}}{20 \text{ cm}^2} = 10 \text{ N}/\text{cm}^2$$

10 N/cm² [4]

21 (a) Complete this table for $y = x^2 - 3$.

x	-3	-2	-1	0	1	2	3
y	6	1	-2	-3	-2	1	6

$$\swarrow y = (-3)^2 - 3 = 9 - 3$$

$$\swarrow y = (0)^2 - 3 = 0 - 3$$

[2]

(b) Draw the graph of $y = x^2 - 3$ for values of x from -3 to 3.

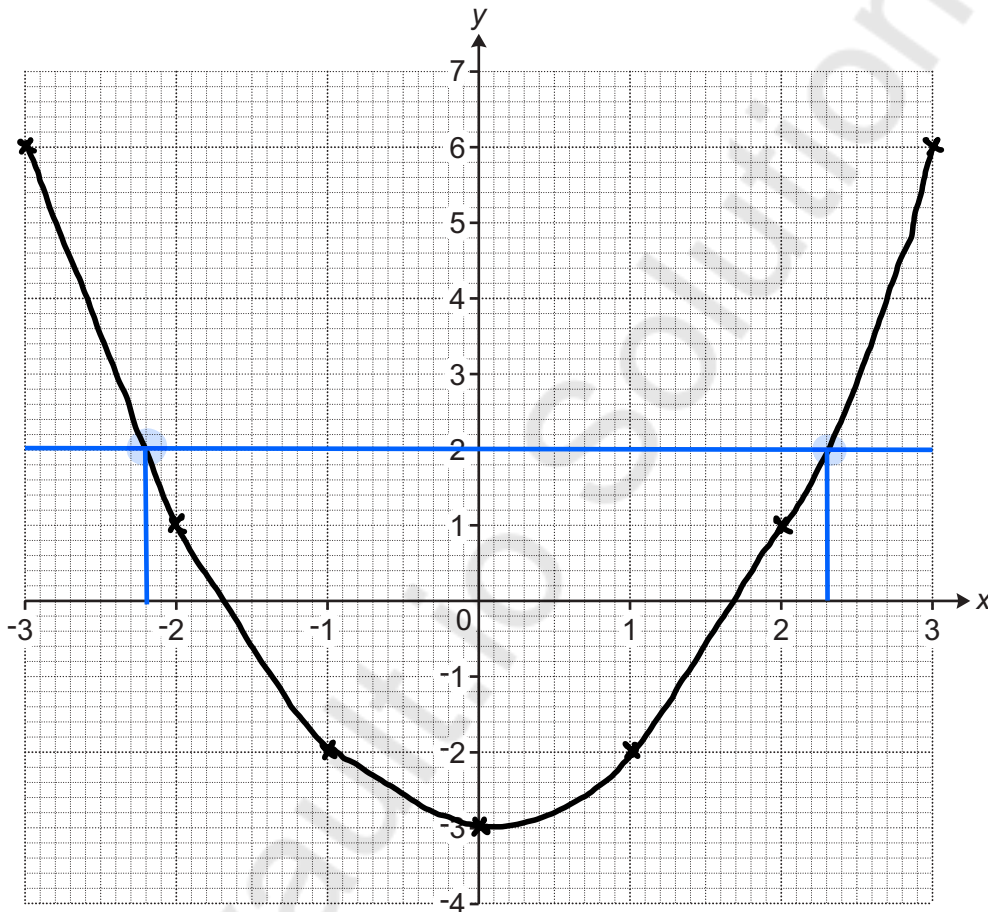

[3]

(c) Use your graph to solve $x^2 - 3 = 2$.

Draw $y = 2$

(c) $x = -2.2$ or $x = 2.3$ [2]

- 22 A journalist is going to do a survey to find out whether people aged 15 or less spend more time playing computer games than people aged more than 15.

The journalist says their sample will be the first 20 people leaving a particular shop after 9 am next Monday.

- (a) Give **one** reason why the journalist's sample is unlikely to give reliable information.

..... **Small sample**
 [1]

- (b) Make **three** suggestions to help the journalist obtain a sample that may give more reliable information.

1 **Larger sample**

 2 **Vary time of day**

 3 **Vary the location**
 [3]

- 23 The diagram shows a straight line crossing two parallel lines.

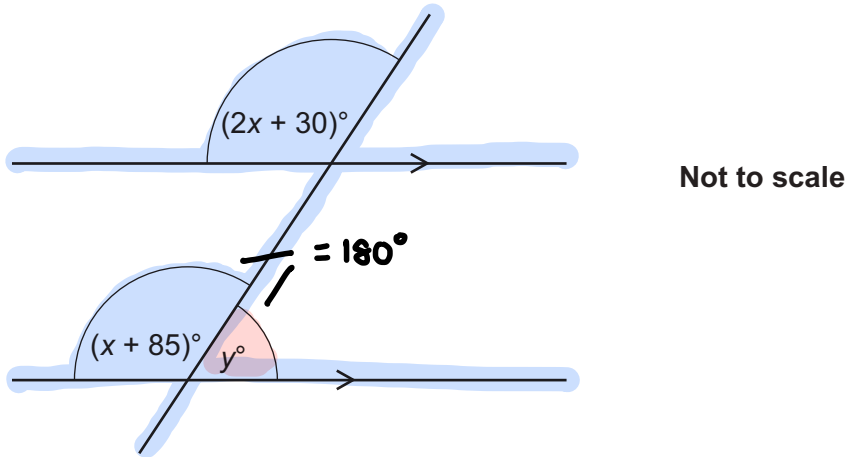

Find the value of y .
You must show your working.

$$\begin{array}{r} 2x + 30 = x + 85 \\ -x \qquad -x \end{array}$$

$$\begin{array}{r} x + 30 = 85 \\ -30 \quad -30 \end{array}$$

$$x = 55$$

$$\begin{array}{r} x + 85 \\ 55 + 85 = 140 \end{array}$$

$$\begin{array}{r} y = 180 - 140 \\ = 40 \end{array}$$

$$y = \underline{40} \dots\dots\dots [6]$$

END OF QUESTION PAPER

