

Monday 13 June 2022 – Morning

GCSE (9–1) Mathematics

J560/03 Paper 3 (Foundation Tier)

Time allowed: 1 hour 30 minutes



You must have:

- the Formulae Sheet for Foundation Tier (inside this document)

You can use:

- a scientific or graphical calculator
- geometrical instruments
- tracing paper



Please write clearly in black ink. **Do not write in the barcodes.**

Centre number

--	--	--	--	--

Candidate number

--	--	--	--

First name(s)

Last name

INSTRUCTIONS

- Use black ink. You can use an HB pencil, but only for graphs and diagrams.
- Write your answer to each question in the space provided. If you need extra space, use the lined pages at the end of this booklet. The question numbers must be clearly shown.
- Answer **all** the questions.
- Where appropriate, your answer should be supported with working. Marks might be given for using a correct method, even if your answer is wrong.
- Use the π button on your calculator or take π to be 3.142 unless the question says something different.

INFORMATION

- The total mark for this paper is **100**.
- The marks for each question are shown in brackets [].
- This document has **24** pages.

ADVICE

- Read each question carefully before you start your answer.

Answer **all** the questions.

- 1 (a) Write down a factor of 18.

1 18
2 9
3 6

(a) **1** [1]

- (b) Write down a square number between 10 and 20.

1 4 9 **16** 25

(b) **16** [1]

- (c) Write $\frac{1}{4}$ as a decimal.

$$1 \div 4 = 0.25$$

(c) **0.25** [1]

- (d) Find the two numbers which multiply together to make 40 **and** add together to make 13.

1 40
2 20
4 10
5 8

(d) **5** and **8** [2]

- 2 (a) Here is a shape.

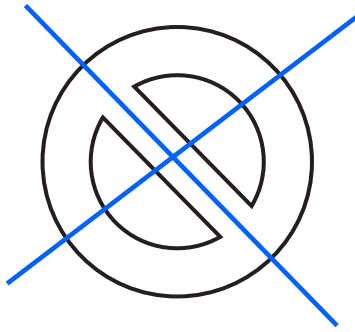

On the diagram, draw the shape's two lines of symmetry.

[1]

- (b) Here is another shape.

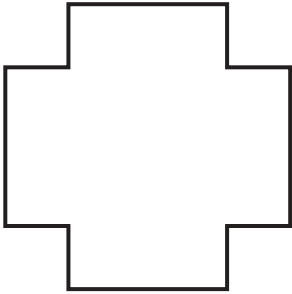

Write down the order of rotation symmetry of the shape.

(b) **4** [1]

- (c) (i) Sketch a quadrilateral that has exactly one line of symmetry.

[1]

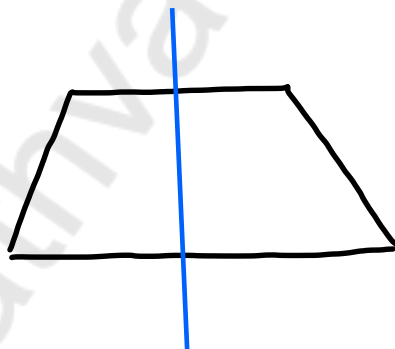

- (ii) Write down the mathematical name of your quadrilateral.

(c)(ii) **Trapezium** [1]

3 Here are the first four dot patterns in a sequence.

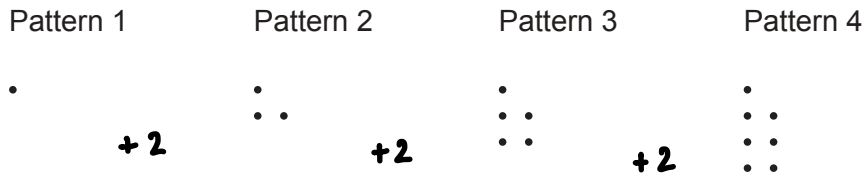

(a) Draw Pattern 5 in the sequence.

[1]



(b) Without drawing, work out how many dots are in Pattern 8 of the sequence.
Explain how you worked out your answer.

$$4 \times 2 = 8 \text{ dots more}$$

$$7 + 8 = 15 \text{ dots}$$

.....15..... becauseit goes up in 2 dots each time.....

..... [2]

- 4 The diagram shows a circle, centre O, and a line that meets the circle twice.

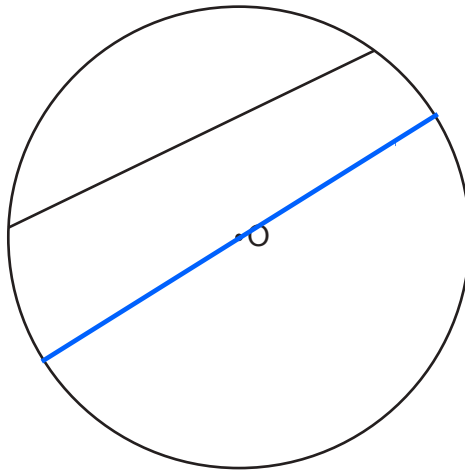

- (a) On the diagram, draw a diameter. [1]

- (b) Write down the mathematical name of the line shown on the diagram.

(b) **Chord** [1]

- 5 A student flips a fair coin and rolls a fair four-sided dice.
The coin can land on heads (H) or on tails (T).
The dice has sides numbered from 5 to 8.

- (a) Complete this table to show all the possible outcomes.

		Dice			
		5	6	7	8
Coin	H	H5	H6	H7	H8
	T	T5	T6	T7	T8

[2]

- (b) Find the probability of getting a tail with an even number.
Give your answer as a fraction in its simplest form.

$$\frac{2}{8} = \frac{1}{4}$$

(b) $\frac{1}{4}$ [2]

6 A test has 20 questions.

Amaya attempts all of the questions.
She gets 65% of the questions correct.
Kai gets six of the questions wrong.

Who has the smallest number of questions wrong?
Show working to support your answer.

Amaya

65% = correct

35% = incorrect

$0.35 \times 20 = 7$ incorrect

Kai

6 incorrect

Kai because Amaya gets 7 wrong.

[3]

- 7 (a) In a recipe, the ratio of the amount of flour needed to the amount of butter needed is 4 : 1. Rowan mixes 4 kg of flour with 1 g of butter.

Explain what Rowan has done wrong.

.....The units are different.....

 [1]

- (b) Azmi gives $\frac{1}{10}$ of their earnings to charity and keeps the remainder.

For Azmi's earnings, find the ratio of the amount they give to charity to the amount they keep.

Give your answer in its simplest form.

$$\frac{1}{10} \text{ Charity}$$

$$1 - \frac{1}{10} = \frac{9}{10} \text{ Kept}$$

$$\frac{1}{10} : \frac{9}{10}$$

$$\begin{array}{ccc} \times 10 & & \times 10 \\ 1 & : & 9 \end{array}$$

(b) 1 : 9 [2]

- 8 (a) Simplify.

$$2 \times 3a$$

(a) 6a [1]

- (b) Simplify.

$$\frac{2x^5}{4x}$$

$$\frac{2}{4} = \frac{1}{2}$$

$$\frac{x^5}{x} = \frac{x^4}{1}$$

(b) $\frac{x^4}{2}$ [2]

- 9 Ling is paid £23.40 per hour for working on a weekday.
On a Sunday, Ling is paid at $1\frac{1}{3}$ times this hourly rate.

How much does Ling earn for working 8 hours on a Sunday?

$$1\frac{1}{3} \times 23.40 = 31.20$$

$$31.20 \times 8 = 249.60$$

£ **249.60** [3]

- 10 Each edge of a fair spinner is coloured either red or blue.

The scale shows the probability of the spinner landing on red and of landing on blue.

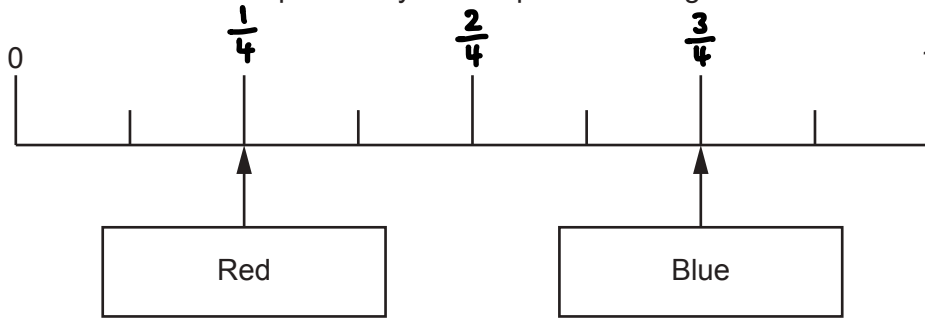

- (a) Write down, as a fraction, the probability of the spinner landing on red.

(a) $\frac{1}{4}$ [1]

- (b) Show that the spinner could not have 15 edges. [2]

$$\frac{1}{4} \times 15 = 3.75$$

3.75 is not an integer.

- 11 Mr Fox invests £400 in a savings account that pays 3% simple interest per year.

Work out the **total** amount of interest Mr Fox will have earned at the end of the 5th year.

$$3\% \times 5 = 15\%$$

$$0.15 \times 400 = 60$$

£ **60** [2]

12 Frankie goes on holiday.

They change £375 into euros (€) at a rate of £1 = €1.15.

They spend €217.49 of this money.

After the holiday, Frankie changes the remaining euros back into pounds at a rate of £1 = €1.28.

Work out how many pounds Frankie gets back.

$$375 \times 1.15 = \text{€}431.25$$

$$\text{€}431.25 - \text{€}217.49 = \text{€}213.76$$

$$213.76 \div 1.28 = \text{£}167$$

£ **167** [4]

- 13 In a fish tank, the fish are either blue or gold or red.

There are 22 red fish.

$\frac{2}{5}$ of the fish are blue.

$\frac{5}{12}$ of the fish are gold.

Work out the total number of fish in the fish tank.

You must show your working.

$$\frac{2}{5} + \frac{5}{12} = \frac{49}{60}$$

$$1 - \frac{49}{60} = \frac{11}{60}$$

$$\frac{11}{60} = 22 \text{ red fish}$$

$$\div 11 \quad \div 11$$

$$\frac{1}{60} = 2 \text{ fish}$$

$$\times 60 \quad \times 60$$

$$\frac{60}{60} \text{ or whole} = 120 \text{ fish}$$

- 15 In this question, all lengths are in centimetres.

The diagram shows an equilateral triangle and a square.

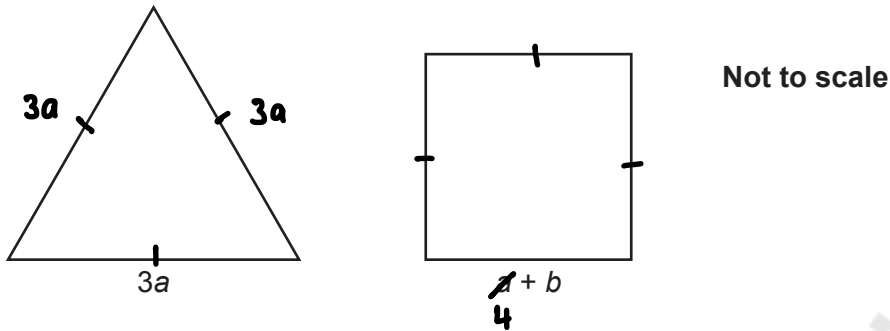

The perimeter of each shape is 36 cm.

Find the value of b .

$$\begin{aligned} \text{Perimeter triangle} &= 3a + 3a + 3a \\ 36 &= 9a \\ \div 9 & \qquad \qquad \div 9 \\ 4 &= a \end{aligned}$$

$$\begin{aligned} \text{Perimeter square} &= 4(4 + b) \\ 36 &= 4(4 + b) \\ \div 4 & \qquad \qquad \div 4 \\ 9 &= 4 + b \\ -4 & \qquad -4 \\ 5 &= b \end{aligned}$$

$$b = \dots 5 \dots \dots \dots [4]$$

- 16 For each statement, complete the box to show the power of 10.

(a) One million = $10^{\boxed{6}}$ $1,000,000 = 10 \times 10 \times 10 \times 10 \times 10 \times 10$ [1]

(b) One thousandth = $10^{\boxed{-3}}$ $1 \div 10 \div 10 \div 10$ [1]

- 17 Some boxes are each in the shape of a cuboid.
The base of each box is exactly 35 cm by 45 cm.

The boxes are to be placed on their base, side by side against a wall.

If all the shorter sides or if all the longer sides are against the wall, they fit perfectly with no gaps.

Find the shortest possible length of the wall.

$$\begin{array}{c} 35 \\ / \quad \backslash \\ 5 \quad 7 \end{array}$$

$$\begin{array}{c} 45 \\ / \quad \backslash \\ 9 \quad 5 \\ / \quad \backslash \\ 3 \quad 3 \end{array}$$

$$35 = 5 \times 7$$

$$45 = 3 \times 3 \times 5$$

$$\begin{aligned} \text{LCM} &= 3 \times 3 \times 5 \times 7 \\ &= 315 \end{aligned}$$

..... **315** cm [4]

- 18 The mass of a stone is 680 g.
The density of the stone is 1.6 g/cm^3 .

(a) Work out the volume of the stone.

$$\begin{aligned} \frac{m}{D} &= V & V &= \frac{m}{D} \\ & & &= \frac{680 \text{ g}}{1.6 \text{ g/cm}^3} \\ & & &= 425 \text{ cm}^3 \end{aligned}$$

(a) **425** cm^3 [2]

(b) Write 1.6 g/cm^3 in kg/m^3 .

$$\frac{1.6 \text{ g}}{1 \text{ cm}^3} = \frac{0.0016 \text{ kg}}{1 \times 10^{-6} \text{ m}^3} = 1600 \text{ kg/m}^3$$

$\xrightarrow{\div 1000}$
 $\xrightarrow{\div 100^3}$

(b) **1600** kg/m^3 [1]

19 (a) Multiply out and simplify.

$$(x-4)(x+5)$$

$$x^2 + 5x - 4x - 20$$

$$x^2 + x - 20$$

(a) $x^2 + x - 20$ [2]

(b) Factorise.

$$\sqrt{x^2 - 25}$$

$$(x + 5)(x - 5)$$

(b) $(x + 5)(x - 5)$ [1]

- 20 Reece travels to school by either walking, cycling or using a bus. The probability that Reece walks is always 0.4. The probability that Reece cycles is always 0.55.

(a) Complete the tree diagram for Monday and Tuesday.

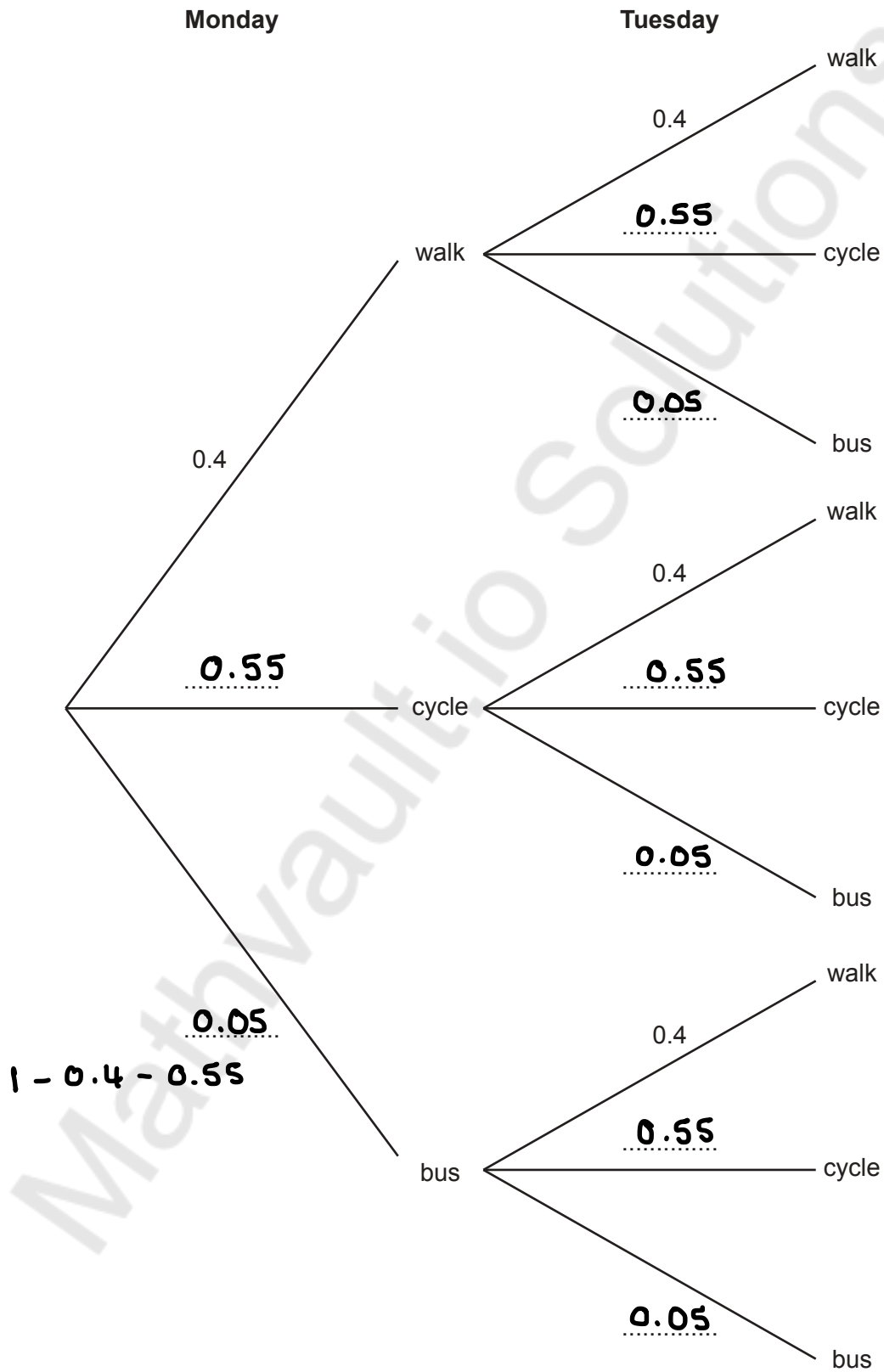

[3]

- (b) Show that the probability that Reece travels to school by the same method on Monday and Tuesday is 0.465. [3]

$$\begin{aligned}
 & p(WW) + p(BB) + p(CC) \\
 & (0.4 \times 0.4) + (0.05 \times 0.05) + (0.55 \times 0.55) \\
 & 0.16 + 0.0025 + 0.3025 = 0.465
 \end{aligned}$$

- 21 Solve the simultaneous equations.

$$\begin{array}{r}
 3x + y = 11 \\
 \underline{x + y = 3} \\
 2x = 8 \\
 \div 2 \qquad \qquad \div 2
 \end{array}$$

$$x = 4$$

$$\begin{array}{r}
 x + y = 3 \\
 4 + y = 3 \\
 \underline{-4 \qquad -4} \\
 y = -1
 \end{array}$$

$$x = \underline{4} \dots\dots\dots$$

$$y = \underline{-1} \dots\dots\dots [3]$$

22 A sports club has 250 members.

Some of the members wish to change a club rule.

To change a club rule, at least 70% of **all** the members must vote 'yes'.

At a meeting of the sports club, 10 members were absent and did not vote.

The other members voted yes: no: don't know in the ratio 11:3:1.

Did enough members vote 'yes' to change the rule?

Show how you decide.

$$250 - 10 = 240$$

Y : N : Don't know

$$11 : 3 : 1 = 15 \text{ parts}$$

$$\times 16$$

$$240 \div 15 = 16$$

176 voted 'yes'

$$\frac{176}{250} \times 100 = 70.4\%$$

Yes because 70.4% of the members voted 'yes'.

.....

.....

.....

..... [5]

23 This is a sketch of the graph of $y = x^2 - 10x + 16$.

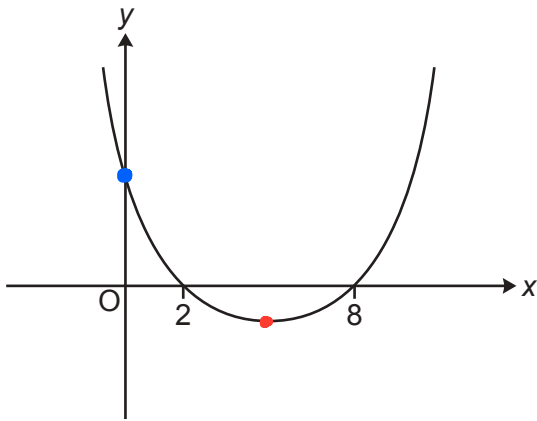

Not to scale

(a) Write down the value of the y-intercept.

$$y = (0)^2 - 10(0) + 16$$

$$y = 16$$

(a) 16 [1]

(b) Write down the x-coordinate of the turning point.

$$\frac{2 + 8}{2} = \frac{10}{2} = 5$$

(b) 5 [1]

- 24 1600 fish are released into a new lake which has no fish.
The number of fish is expected to increase by 5% each year.

- (a) The table shows the expected number of fish in the lake at the end of 1 year and at the end of 2 years.

Complete the table.

Round your answers to the nearest integer.

$$1764 \times 1.05 = 1852.2$$

$$\approx 1852$$

$$1852 \times 1.05 = 1944.6$$

$$\approx 1945$$

Years after release	0	1	2	3	4
Expected number of fish	1600	1680	1764	1852	1945

[3]

- (b) Use the table to draw a suitable graph to show the expected number of fish in the lake.

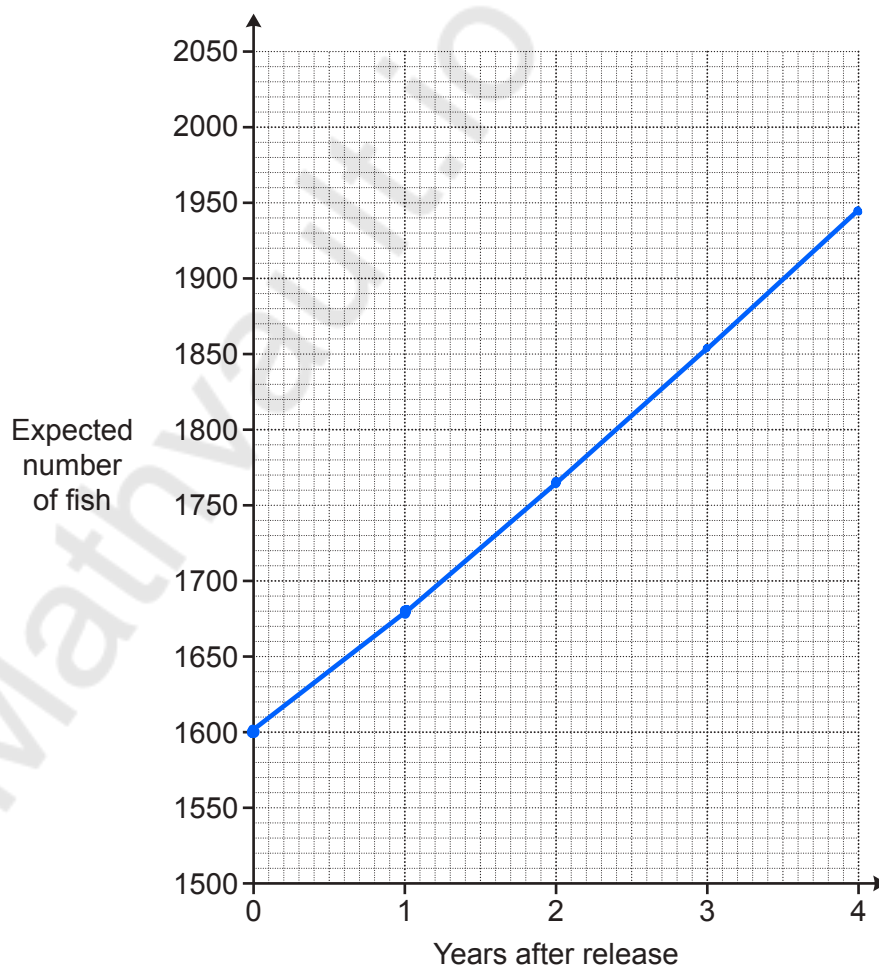

[3]

- (c) A maximum of 2000 fish can live in the lake.

What effect would you expect this to have on the shape of your graph after 4 years?

The graph will increase to 2000 then level off.

[2]

TURN OVER FOR QUESTIONS 25 AND 26

- 25 A garage is trying to sell a car.
The price of the car is normally £18000.

In a sale, the price of the car is reduced by 30%.
As a special offer, the sale price is then reduced by $r\%$.
The special offer price is £9450.

Find the value of r .
You must show your working.

$$\begin{array}{r} 100\% = \text{£}18,000 \\ \times 0.7 \qquad \qquad \qquad \times 0.7 \\ 70\% = \text{£}12,600 \end{array}$$

$$\frac{\text{change}}{\text{original}} \times 100$$

$$\frac{12600 - 9450}{12600} \times 100 = 25$$

$$r = \underline{25} \dots \dots \dots [5]$$

- 26 The diagram shows a triangular prism and a cube.
The ends of the prism are right-angled triangles with base 16 cm and height 12 cm.
The prism is 18 cm long.

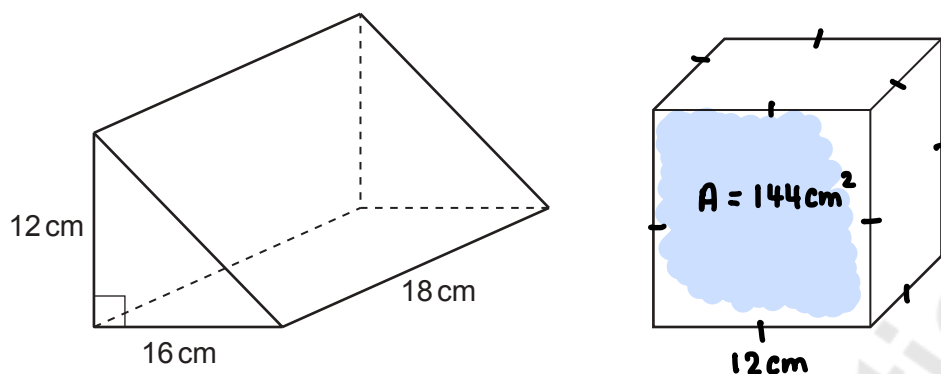

The volume of the prism is equal to the volume of the cube.

Find the **surface area of the cube**.
You must show your working.

$$\begin{aligned}
 \text{Volume prism} &= \frac{1}{2}bh \times \text{length of prism} \\
 &= \frac{1}{2} \times 16 \times 12 \times 18 \\
 &= 1728 \text{ cm}^3
 \end{aligned}$$

$$\text{Volume cube} = 1728 \text{ cm}^3$$

$$\begin{aligned}
 \text{Side length} &= \sqrt[3]{1728} \\
 &= 12 \text{ cm}
 \end{aligned}$$

$$\begin{aligned}
 \text{Surface Area} &= 144 \text{ cm}^2 \times 6 \\
 &= 864 \text{ cm}^2
 \end{aligned}$$

..... **864** cm² [6]

END OF QUESTION PAPER

