

Tuesday 7 June 2022 – Morning

GCSE (9–1) Mathematics

J560/05 Paper 5 (Higher Tier)

Time allowed: 1 hour 30 minutes



You must have:

- the Formulae Sheet for Higher Tier (inside this document)

You can use:

- geometrical instruments
- tracing paper

Do not use:

- a calculator



Please write clearly in black ink. **Do not write in the barcodes.**

Centre number

--	--	--	--	--

Candidate number

--	--	--	--

First name(s)

Last name

INSTRUCTIONS

- Use black ink. You can use an HB pencil, but only for graphs and diagrams.
- Write your answer to each question in the space provided. If you need extra space, use the lined pages at the end of this booklet. The question numbers must be clearly shown.
- Answer **all** the questions.
- Where appropriate, your answer should be supported with working. Marks might be given for using a correct method even if your answer is wrong.

INFORMATION

- The total mark for this paper is **100**.
- The marks for each question are shown in brackets [].
- This document has **24** pages.

ADVICE

- Read each question carefully before you start your answer.



Answer **all** the questions.

- 1 Two pupils are given data that shows the estimated number of computer tablet users worldwide from 2014 to 2018.

(a) Li creates this pie chart to show the data.

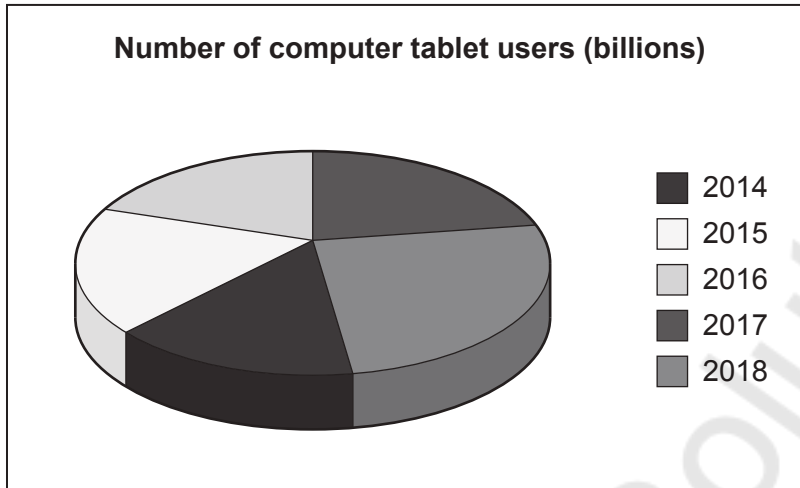

Write down two reasons why Li's pie chart is not suitable to represent the data.

- 1 *No totals or figures given*
- 2 *3D distorts perspective*

[2]

(b) Amaya creates this line graph to show the same data.

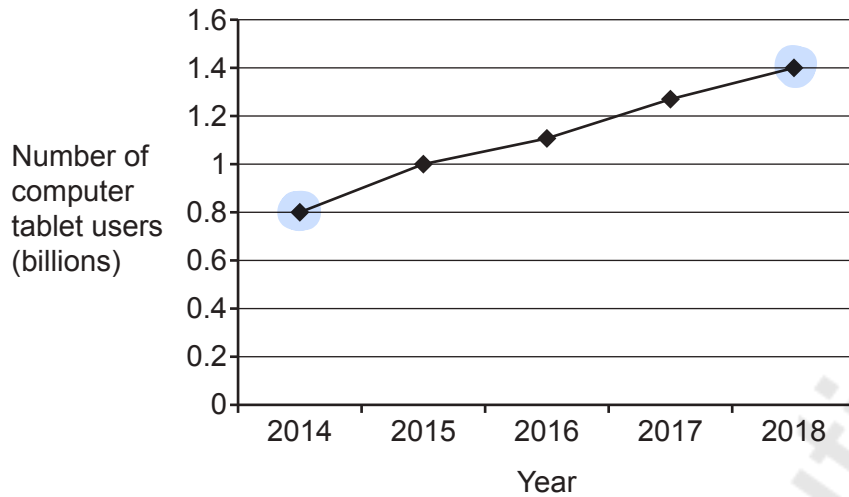

Work out the percentage increase in the number of computer tablet users from 2014 to 2018.

$$\frac{\text{change}}{\text{original}} \times 100$$

$$\frac{1.4 - 0.8}{0.8} \times 100 \quad \begin{array}{r} 1.4 \\ - 0.8 \\ \hline 0.6 \end{array}$$

$$\frac{0.6}{0.8} \times 100$$

$$\frac{6}{8} = \frac{3}{4} = 0.75$$

$$0.75 \times 100 = 75$$

(b) **75** % [4]

- 2 The scale diagram below shows the position of two castles, J and K.

Scale: 1 cm represents 2 km

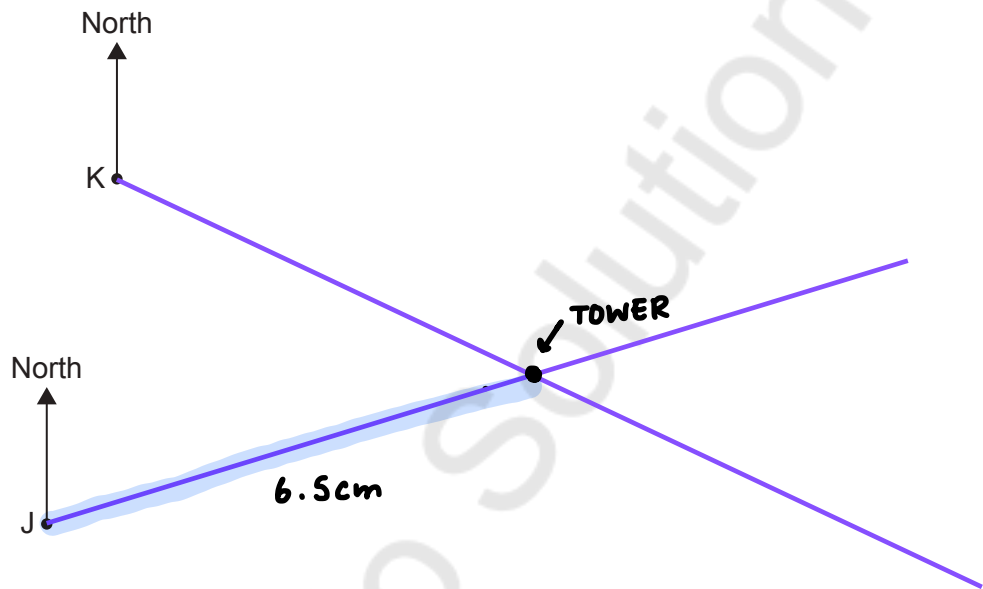

The bearing of a tower from castle J is 072° .
The bearing of the tower from castle K is 116° .

Use construction to find the distance from castle J to the tower.
Give your answer to the nearest 0.1 km.

$$1 \text{ cm} = 2 \text{ km}$$

↘ ↗
x2

$$6.5 \times 2 = 13 \text{ km}$$

..... **13** km [4]

- 3 Dinosaurs first appeared on Earth 2.4×10^8 years ago.
Dinosaurs became extinct on Earth 7×10^7 years ago.

(a) Explain why it is appropriate to use standard form for these numbers.

.....The ordinary numbers are very large.....
.....
..... [1]

(b) Use the given information to work out how long dinosaurs existed on Earth.
Give your answer in standard form.

$$(2.4 \times 10^8) - (7 \times 10^7)$$

$$\div 10 \left(\begin{array}{c} \downarrow \\ \end{array} \right) + 1$$

$$(2.4 \times 10^8) - (0.7 \times 10^8)$$

$$\begin{array}{r} 2.4 \\ - 0.7 \\ \hline 1.7 \end{array}$$

$$1.7 \times 10^8$$

(b) 1.7×10^8 [3]

- 4 (a) Complete this statement by writing the missing power in the box.

$$784 = 2^{\boxed{4}} \times 7^2$$

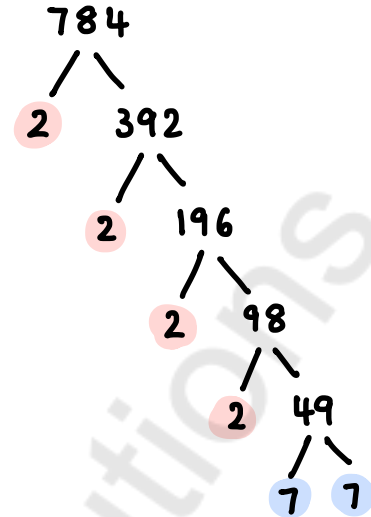

[1]

- (b) Use your answer to part (a) to find the value of $\sqrt{784}$.

$$\sqrt{2^4 \times 7^2}$$

$$= 2^2 \times 7$$

$$= 4 \times 7$$

$$= 28$$

(b) **28** [2]

- 5 Recipes measure small quantities in teaspoons and tablespoons.
3 teaspoons is equivalent to 1 tablespoon.

A cake recipe uses $\frac{3}{4}$ of a teaspoon of salt and **3 teaspoons** of baking powder.

The ratio of salt to baking powder used in the recipe can be written in the form $1 : n$.

Find the value of n .

$$\begin{array}{r} \frac{3}{4} : 3 \\ \times 4 \qquad \qquad \times 4 \\ \hline 3 : 12 \\ \div 3 \qquad \qquad \div 3 \\ \hline 1 : \boxed{4} \\ 1 : \boxed{n} \end{array}$$

$$n = \overset{4}{\dots\dots\dots} \quad [3]$$

- 6 Morgan is playing a computer game.
They can score 0, 1, 2 or 3 points on each turn.
They record their scores for 100 turns.
The table shows the relative frequencies of their scores.

Score	0	1	2	3
Relative frequency	0.08	0.42	0.38	0.12 = 1

- (a) Complete the table.

$$\begin{array}{r} 0.08 \\ 0.42 \\ + 0.38 \\ \hline 0.88 \end{array} \qquad \begin{array}{r} 0.90 \\ - 0.88 \\ \hline 0.12 \end{array}$$

[2]

- (b) Morgan says

I scored more than 160 points in total in my 100 turns.

Is Morgan correct?
Show how you decide.

Totals

0 pts $100 \times 0.08 = 8$ ($8 \times 0 = 0$ pts)

1 pt $100 \times 0.42 = 42$ ($42 \times 1 = 42$ pts)

2 pts $100 \times 0.38 = 38$ ($38 \times 2 = 76$ pts)

3 pts $100 \times 0.12 = 12$ ($12 \times 3 = 36$ pts)

$$\begin{array}{r} 42 \\ 76 \\ + 36 \\ \hline 154 \end{array}$$

No $154 < 160$

[4]

- 7 (a) A car accelerates at 4.06 m/s^2 for 10.1 seconds from an initial velocity of 2.93 m/s .

Harper rounds each value to 1 significant figure.
Harper uses the rounded values and the formula

$$s = ut + \frac{1}{2}at^2$$

to estimate the distance travelled in the 10.1 seconds.
Harper's answer is 430 metres.

Using Harper's method, show that their answer is wrong. [4]

$$a = 4.06 \approx 4$$

$$t = 10.1 \approx 10$$

$$u = 2.93 \approx 3$$

$$\begin{aligned} s &= (3)(10) + \frac{1}{2}(4)(10)^2 \\ &= 30 + \frac{1}{2}(400) \\ &= 30 + 200 \\ &= 230 \text{ m} \end{aligned}$$

- (b) Rearrange this formula to make t the subject.

$$s = \frac{1}{2}at^2$$

$$\times 2 \quad \times 2$$

$$2s = at^2$$

$$\div a \quad \div a$$

$$\frac{2s}{a} = t^2$$

$$\sqrt{\quad} \quad \sqrt{\quad}$$

$$\sqrt{\frac{2s}{a}} = t$$

(b) $t = \sqrt{\frac{2s}{a}}$ [3]

8 A bag only contains red marbles, blue marbles and yellow marbles.

- The probability of picking a red marble is $\frac{2}{5}$.
- There are nine yellow marbles.
- The probability of picking a blue marble is three times as likely as picking a yellow marble.

Work out the **total** number of marbles in the bag.

You must show your working.

$$p(\text{red}) = \frac{2}{5} \quad p(\text{yellow}) = \frac{9}{x} \quad p(\text{blue}) = \frac{9}{x} \times 3$$

$$= \frac{27}{x}$$

$$p(\text{yellow or blue}) = 1 - p(\text{red})$$

$$= 1 - \frac{2}{5}$$

$$= \frac{3}{5}$$

$$\frac{9}{x} + \frac{27}{x} = \frac{3}{5}$$

$$\frac{36}{x} = \frac{3}{5}$$

$$5 \times 12 = 60$$

..... 60

[5]

- 9 The diagram shows the scale drawing of a sandpit, ABCD. It also shows the arc of all points in the sandpit that are 80 cm from corner A.

Scale: 1 cm represents 20 cm

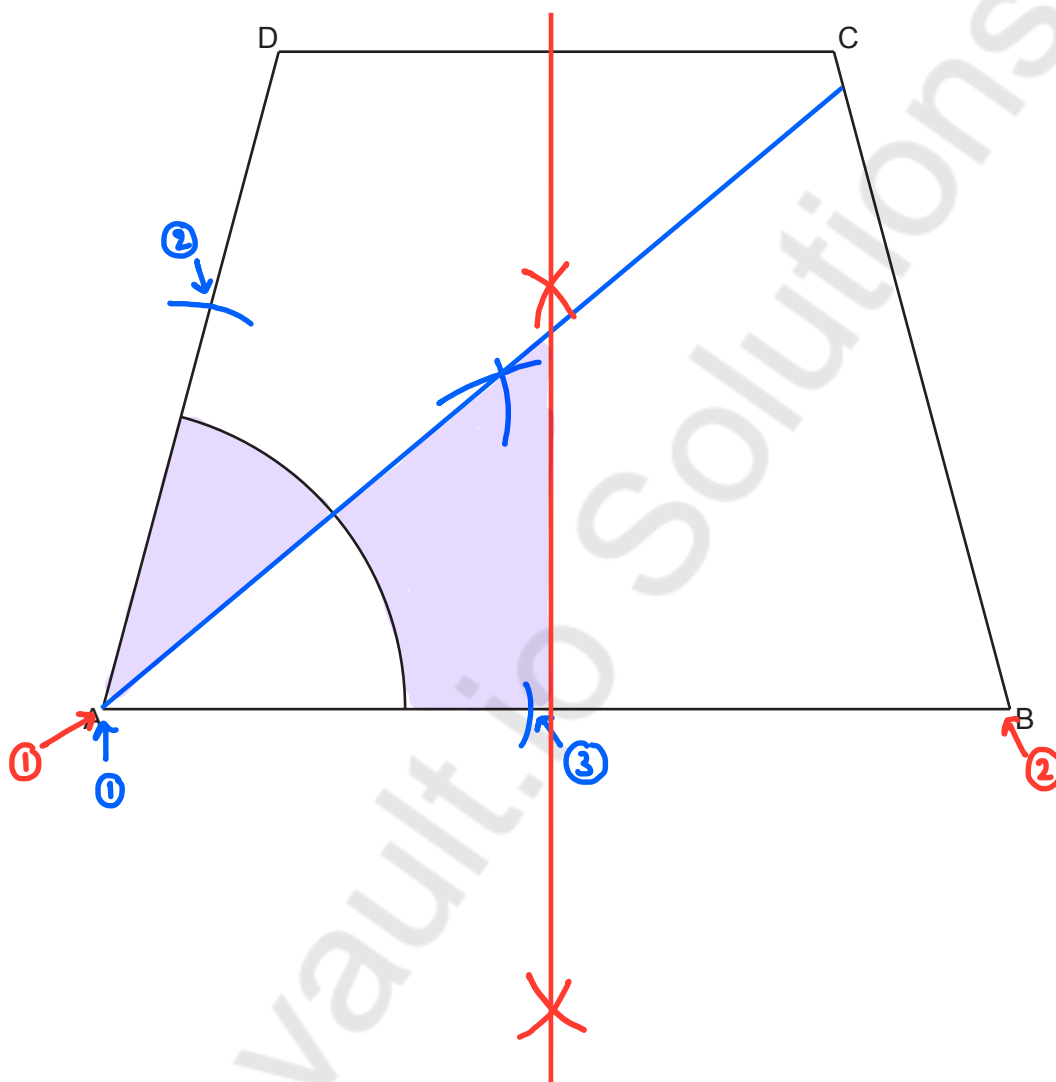

A game is played by throwing a ball into the sandpit. Points may be scored when the ball lands in the sandpit.

- 1 point if the ball lands within 80 cm of corner A, ✓
- and
- 1 point if the ball is closer to side AB than side AD, **Angle bisector of $\angle DAB$**
- and
- 1 point if the ball is closer to corner A than corner B. **Perpendicular bisector of AB**

By completing the construction, find and shade the regions where 2 points can be scored. Show all your construction lines.

[6]

10 (a) Enlarge triangle A with scale factor 1.5 and centre of enlargement (-8, 0).

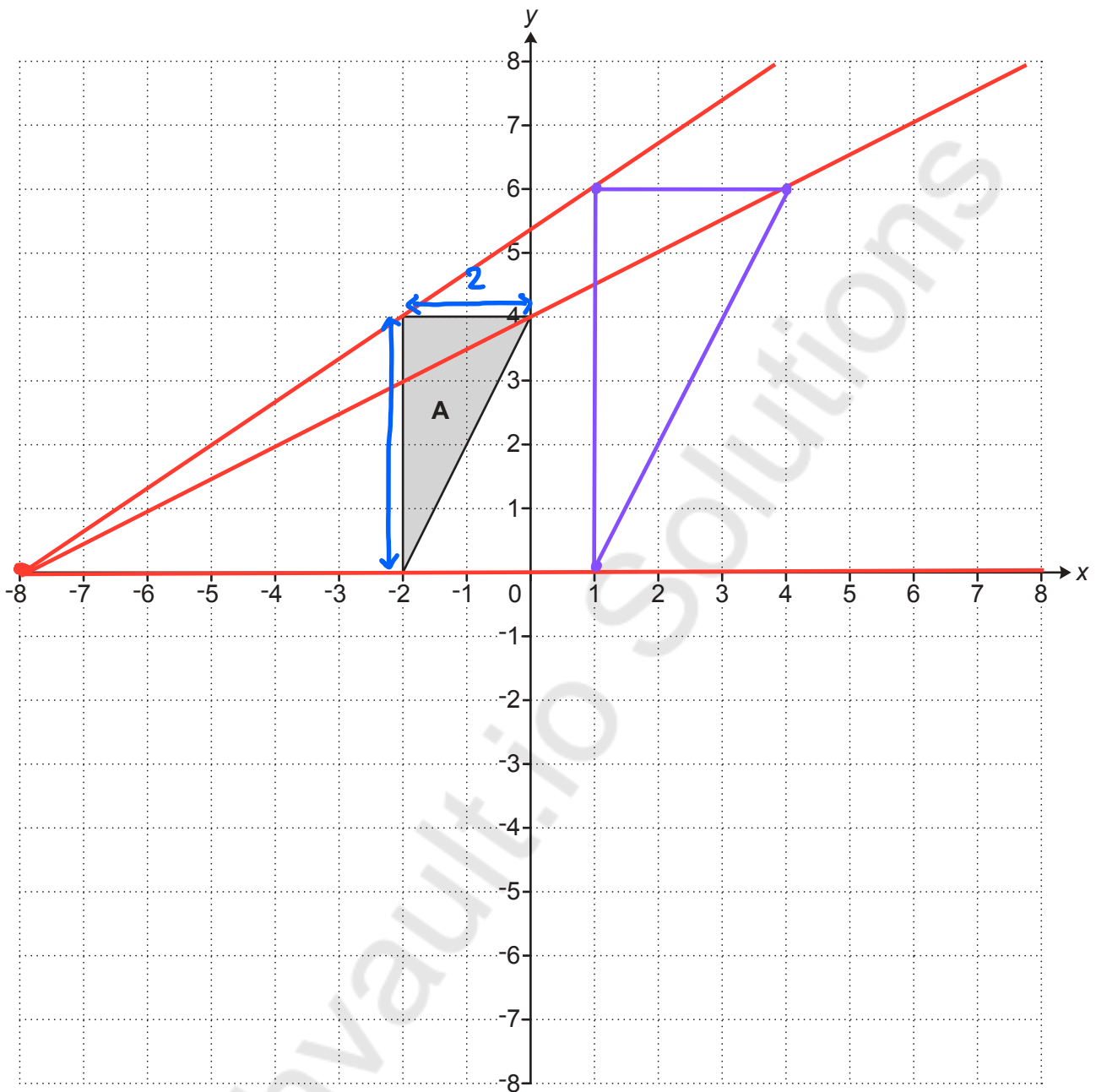

$$2 \times 1.5 = 3$$

$$4 \times 1.5 = 6$$

[3]

(b) Triangle **A** and triangle **B** are shown on the coordinate grid below.

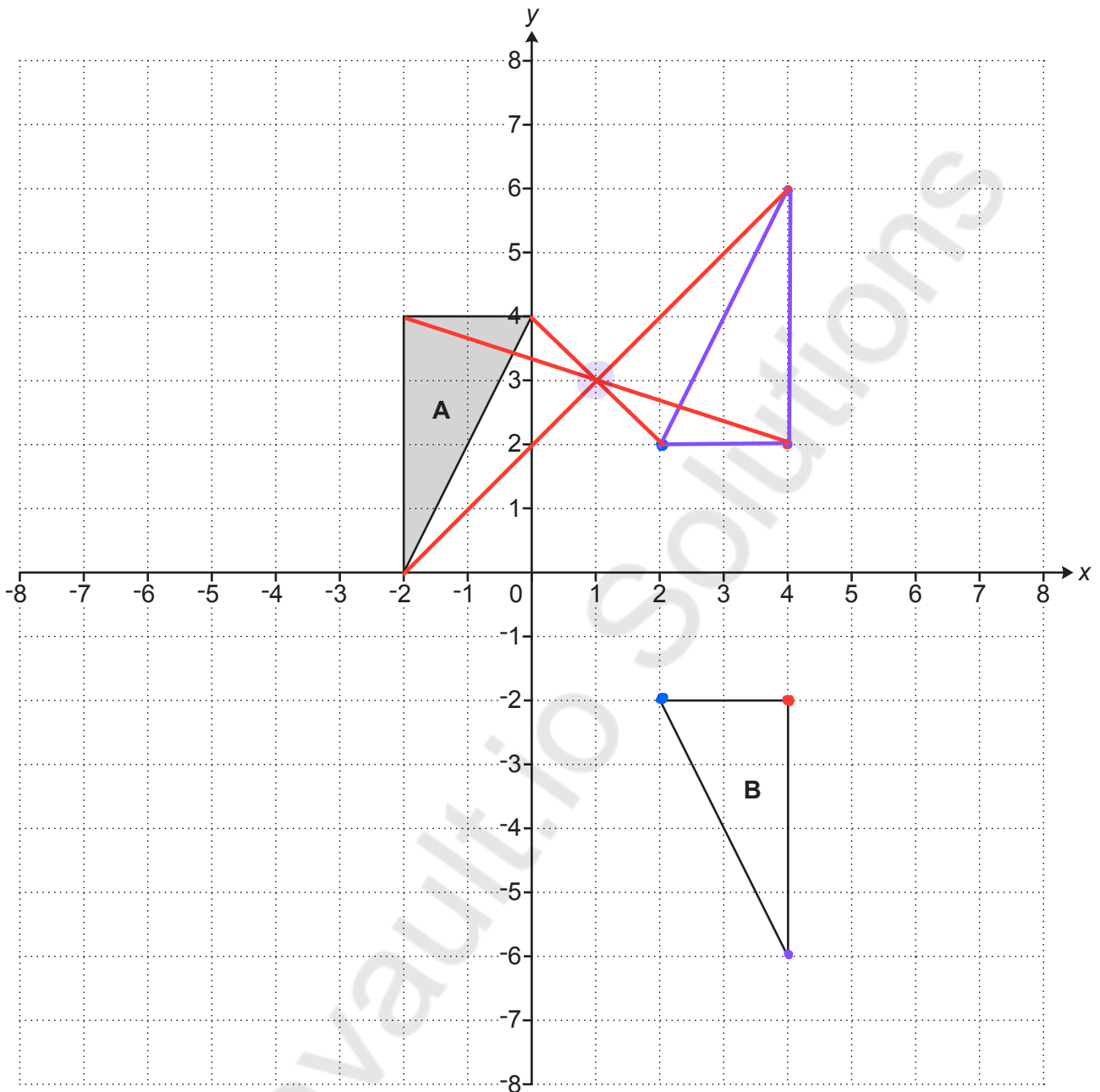

Triangle **A** is mapped onto triangle **B** using a combination of two transformations:

- a transformation **T**, followed by
- a reflection in the x -axis.

Describe fully transformation **T**.

Rotation 180° about $(1, 3)$

[4]

- 11 y is inversely proportional to x^2 .
 $y = 9$ when $x = 2$.

Find the value of y when $x = 10$.

$$y \propto \frac{1}{x^2}$$

$$y = \frac{k}{x^2}$$

$$9 = \frac{k}{2^2}$$

$$\underset{\times 4}{9} = \frac{\underset{\times 4}{k}}{4}$$

$$36 = k \quad \therefore y = \frac{36}{x^2}$$

$$= \frac{36}{10^2}$$

$$= \frac{36}{100}$$

$$= 0.36$$

$$y = \dots \mathbf{0.36} \dots \dots \dots [3]$$

- 12 An athlete goes for a training run.
The graph shows their speed as they run.

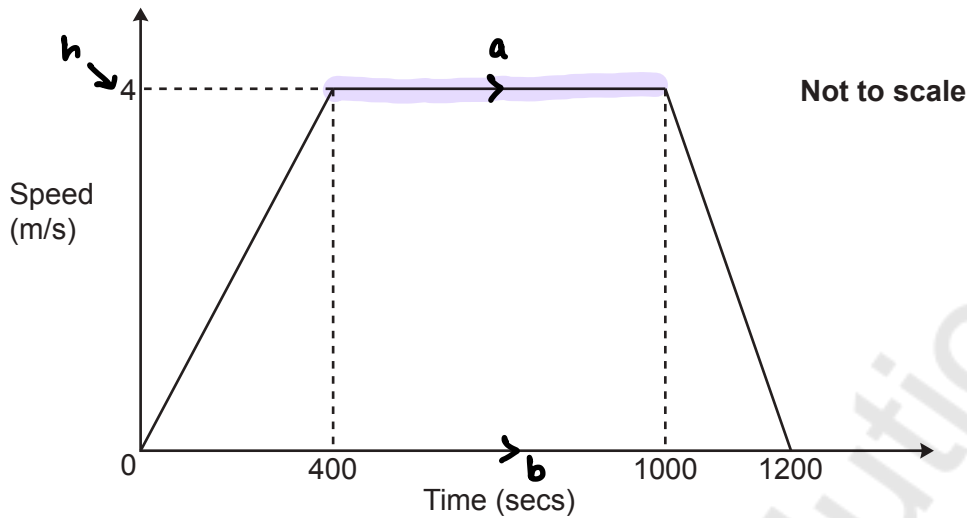

- (a) Write down the athlete's **acceleration** between 400 seconds and 1000 seconds.
change in speed

(a) **0** m/s² [1]

- (b) Work out the athlete's average speed, in m/s, during the 1200 seconds.
You must show your working.

$$s = \frac{D}{T} \quad S = \frac{D}{T}$$

$$D = \text{area under graph}$$

$$= \frac{1}{2} (a + b) \times h$$

$$= \frac{1}{2} (600 + 1200) \times 4$$

$$= \frac{1}{2} (1800) \times 4$$

$$= 900 \times 4$$

$$= 3600 \text{ m}$$

$$S = \frac{3600 \text{ m}}{1200 \text{ s}}$$

$$= 3 \text{ m/s}$$

(b) **3** m/s [5]

- 13 The graph of $y = x^2 + 6x - 2$ is shown below.
The roots of the equation $x^2 + 6x - 2 = 0$ are at p and q .

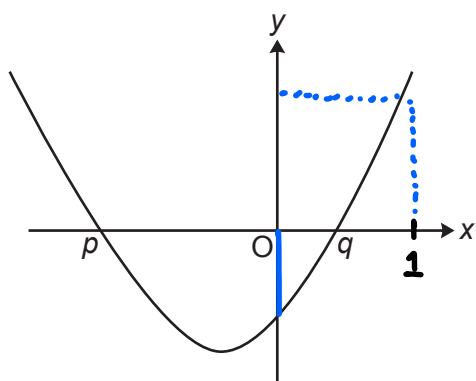

- (a) (i) Calculate y when $x = 1$.

$$\begin{aligned} y &= (1)^2 + 6(1) - 2 \\ &= 1 + 6 - 2 \\ &= 7 - 2 \end{aligned}$$

(a)(i) $y = 5$ [1]

- (ii) Without solving the equation, explain why q must lie between 0 and 1.

When $x=0$, $y < 0$, when $x=1$, $y > 0$

Change of sign $\therefore q$ must be between 0 and 1 [2]

- (iii) Explain why using a method of iteration is not the most appropriate way of finding a solution to this equation.

Iteration gives an estimate.

..... [1]

- (b) The exact value of q is $\frac{-6 + \sqrt{44}}{2}$.

Write $\frac{-6 + \sqrt{44}}{2}$ in the form $a + \sqrt{b}$.

$$\begin{aligned} \sqrt{44} &= \sqrt{4} \times \sqrt{11} \\ &= 2\sqrt{11} \end{aligned}$$

$$\frac{-6 + 2\sqrt{11}}{2} = -3 + \sqrt{11}$$

(b) $-3 + \sqrt{11}$ [3]

- 14 In a survey about music, some students were asked whether they like pop (P) and whether they like rap (R).

The Venn diagram shows some of the results.
 x students liked both types of music.

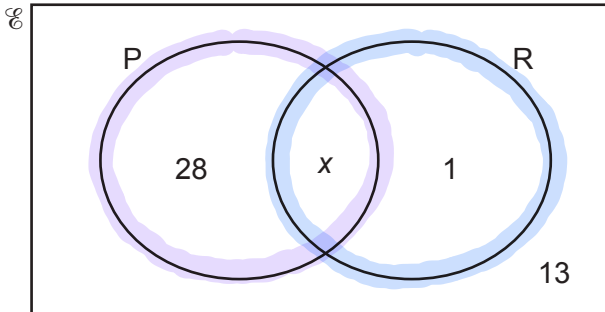

- (a) The ratio of the number of students who liked pop to the number who liked rap was 5 : 2.

Work out the **total** number of students in the survey.

$$P = 28 + x$$

$$R = 1 + x$$

$$P : R$$

$$28 + x : 1 + x = 5 : 2$$

$$\frac{28 + x}{1 + x} = \frac{5}{2}$$

$$2(28 + x) = 5(1 + x)$$

$$56 + 2x = 5 + 5x$$

$$- 2x \quad - 2x$$

$$56 = 5 + 3x$$

$$- 5 \quad - 5$$

$$51 = 3x \quad x = 17$$

$$\div 3 \quad \div 3$$

$$\text{Total} = 28 + 17 + 1 + 13$$

$$= 59$$

(a) 59 [4]

- (b) One of the students is selected at random.

Find the probability that this student does **not** like rap given that they like pop.

$$28 + 17 = 45$$

(b) $\frac{28}{45}$ [2]

- 15 ABC is an equilateral triangle of side length 2 cm.
M is the midpoint of AC.

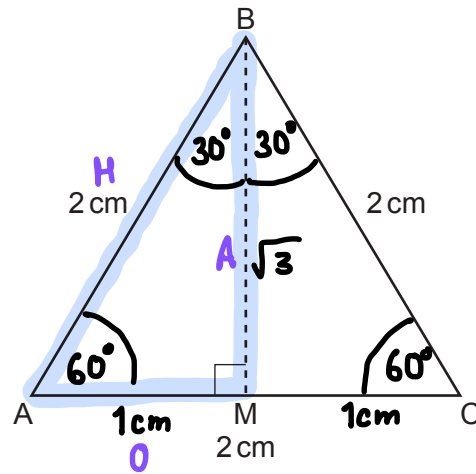

Using this diagram, show that $\tan 30^\circ = \frac{1}{\sqrt{3}}$.

[4]

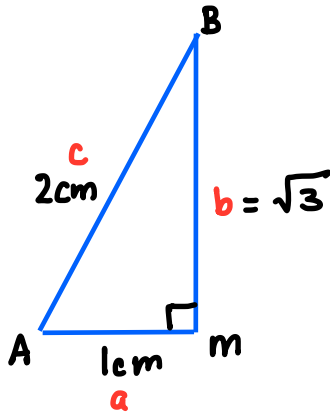

$$a^2 + b^2 = c^2$$

$$1^2 + b^2 = 2^2$$

$$b^2 = 2^2 - 1^2$$

$$b = \sqrt{2^2 - 1^2}$$

$$= \sqrt{4 - 1}$$

$$= \sqrt{3}$$

$$\tan \theta = \frac{O}{A}$$

$$\tan 30 = \frac{1}{\sqrt{3}}$$

- 16 Work out $0.\dot{6} \times 0.\dot{5}\dot{4}$ giving your answer as a fraction in its simplest form.
You must show your working.

$$x = 0.\dot{6}$$

$$10x = 6.\dot{6}$$

$$9x = 6$$

$$\div 9 \quad \div 9$$

$$x = \frac{6}{9} = \frac{2}{3}$$

$$y = 0.\dot{5}\dot{4}$$

$$10y = 5.\dot{4}\dot{5}$$

$$100y = 54.\dot{5}\dot{4}$$

$$99y = 54$$

$$\div 99 \quad \div 99$$

$$y = \frac{54}{99} = \frac{6}{11}$$

$$\frac{2}{3} \times \frac{6}{11} = \frac{12}{33} = \frac{4}{11}$$

$$\frac{4}{11}$$

..... [5]

- 17 Charlie is making some wooden frames.
Charlie has a strip of wood 1.6 m long and 2 cm wide.

Not to scale

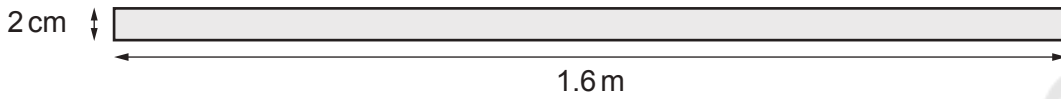

Each frame will be made from four pieces of wood cut from the strip to form a rectangle, as shown below.

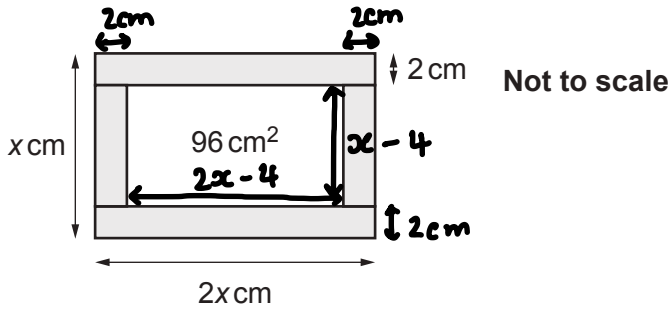

The width of each frame is x cm.
The length of each frame is $2x$ cm.
The area enclosed by each frame must be 96 cm^2 .

Work out the maximum number of frames Charlie can make from the 1.6 m length of wood.
You must show your working.

$$A = l \times w$$

$$(2x - 4)(x - 4) = 96$$

$$2x^2 - 8x - 4x + 16 = 96$$

$$2x^2 - 12x + 16 = 96$$

$$ - 96 \quad - 96$$

$$2x^2 - 12x - 80 = 0$$

$$\div 2 \qquad \qquad \div 2$$

$$x^2 - 6x - 40 = 0$$

$$(x + 4)(x - 10) = 0$$

$$x + 4 = 0$$

$$x = -4$$

X

$$x - 10 = 0$$

$$x = 10$$

✓

$$\begin{aligned} \text{Perimeter of frame} &= 2(2x) + 2(x-4) \\ &= 4x + 2x - 8 \\ &= 6x - 8 \\ &= 6(10) - 8 \\ &= 52 \text{ cm} \end{aligned}$$

$$1.6 \text{ m} \xrightarrow{\times 100} 160 \text{ cm}$$

$$\text{Number of frames } 160 \div 52$$

$$52 \overline{) 160} \quad 3 \text{ r } 4$$

$$\approx 3$$

3

..... [6]

- 18 The diagram shows a shaded shape made by removing sector OAB from sector OCD. Both sectors have an angle of 60° . The radius, OA, of the smaller sector is r cm. The ratio of radius OA to radius OC is 2 : 3.

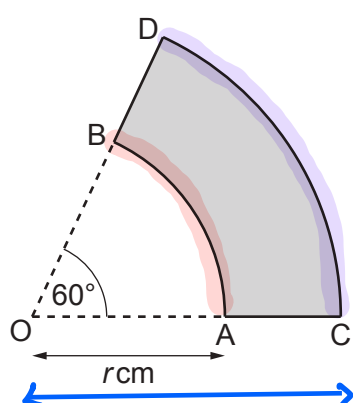

Not to scale

$$OA : OC$$

$$2 : 3$$

$$\div 2, \times 3$$

$$r \div 2, \times 3 = \frac{3}{2}r \text{ [OC]}$$

Work out, in terms of π and r , the **total** length of arc AB and arc CD. Give your answer in its simplest form. You must show your working.

$$\text{Arc length} = \frac{\theta}{360} \times 2\pi r$$

$$\begin{aligned} \text{Arc length AB} &= \frac{60}{360} \times 2\pi r \\ &= \frac{1}{6} \times 2\pi r \\ &= \frac{2}{6} \pi r \\ &= \frac{1}{3} \pi r \text{ cm} \end{aligned}$$

$$\begin{aligned} \text{Arc length CD} &= \frac{60}{360} \times 2\pi \times \frac{3}{2}r \\ &= \frac{1}{6} \times 2\pi \times \frac{3}{2}r \\ &= \frac{1}{3} \pi \times \frac{3}{2}r \\ &= \frac{3}{6} \pi r \\ &= \frac{1}{2} \pi r \end{aligned}$$

$$\begin{aligned} \text{Total length} &= \frac{1}{3} \pi r + \frac{1}{2} \pi r \\ &= \frac{2}{6} \pi r + \frac{3}{6} \pi r \\ &= \frac{5}{6} \pi r \text{ cm} \end{aligned}$$

$$\frac{5}{6} \pi r$$

..... cm [5]

- 19 The graph below shows a circle with centre $(0, 0)$ and equation $x^2 + y^2 = 169$.

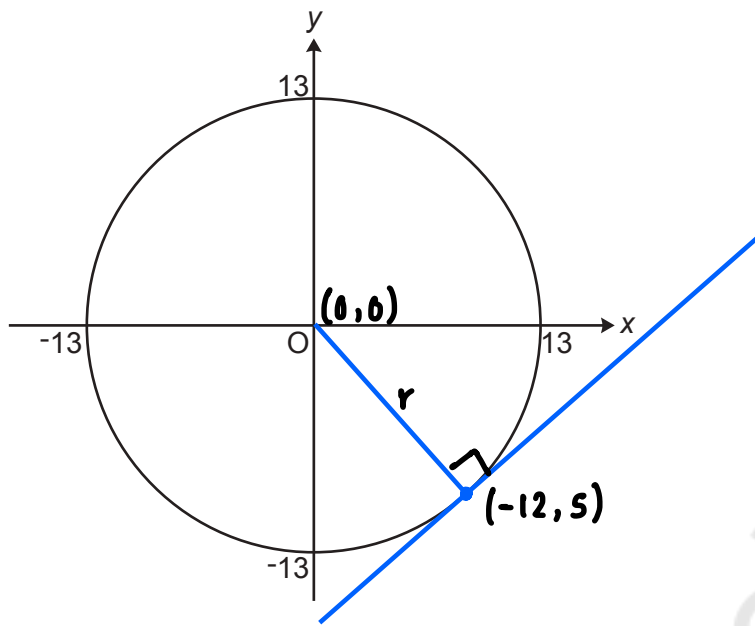

- (a) Show that the point $(-12, 5)$ lies on the circumference of the circle.

[2]

$$x = -12 \quad y = 5 \rightarrow x^2 + y^2 = 169$$

$$(-12)^2 + (5)^2 = 169$$

$$144 + 25 = 169$$

- (b) Find the equation of the tangent to the circle at the point $(-12, 5)$, giving your answer in the form $y = mx + c$.

$$\begin{aligned} \text{Gradient of radius} &= \frac{y_2 - y_1}{x_2 - x_1} && \begin{matrix} (0, 0) & (-12, 5) \\ x_1, y_1 & x_2, y_2 \end{matrix} \\ &= \frac{5 - 0}{-12 - 0} \\ &= \frac{5}{-12} \end{aligned}$$

$$\text{Gradient of tangent} = \frac{12}{5}$$

$$\text{Equation of tangent} = y = mx + c \quad \begin{matrix} \swarrow \text{g-intercept} \\ \uparrow \text{gradient} \end{matrix}$$

$$y = \frac{12}{5}x + c$$

$$5 = \frac{12}{5}(-12) + c \quad \begin{matrix} (-12, 5) \\ x \quad y \end{matrix}$$

$$5 = \frac{-144}{5} + c$$

$$+ \frac{144}{5} \quad + \frac{144}{5}$$

$$5 + \frac{144}{5} = c$$

$$\frac{25}{5} + \frac{144}{5} = c$$

$$\frac{169}{5} = c$$

$$y = \frac{12}{5}x + \frac{169}{5}$$

$$(b) \dots\dots\dots y = \frac{12}{5}x + \frac{169}{5} \dots\dots\dots [5]$$

END OF QUESTION PAPER

