

Wednesday 14 June 2023 – Morning

GCSE (9–1) Mathematics

J560/03 Paper 3 (Foundation Tier)

Time allowed: 1 hour 30 minutes

You must have:

- the Formulae Sheet for Foundation Tier (inside this document)

You can use:

- a scientific or graphical calculator
- geometrical instruments
- tracing paper



Please write clearly in black ink. **Do not write in the barcodes.**

Centre number

--	--	--	--	--

Candidate number

--	--	--	--

First name(s)

Last name

INSTRUCTIONS

- Use black ink. You can use an HB pencil, but only for graphs and diagrams.
- Write your answer to each question in the space provided. If you need extra space use the lined pages at the end of this booklet. The question numbers must be clearly shown.
- Answer **all** the questions.
- Where appropriate, your answer should be supported with working. Marks might be given for using a correct method, even if your answer is wrong.
- Use the π button on your calculator or take π to be 3.142 unless the question says something different.

INFORMATION

- The total mark for this paper is **100**.
- The marks for each question are shown in brackets [].
- This document has **24** pages.

ADVICE

- Read each question carefully before you start your answer.

- 1 (a) These four solids are labelled **A**, **B**, **C** and **D**.

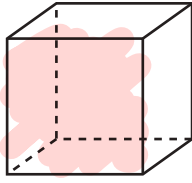
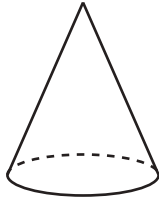
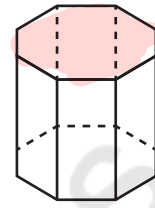
**A****B****C****D**

Write down the letter of the solid that is **not** a prism.

(a) **B** [1]

- (b) These four triangles are labelled **E**, **F**, **G** and **H**.

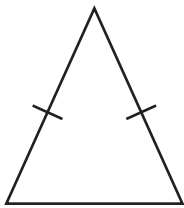
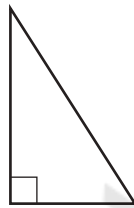
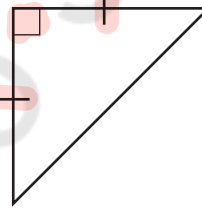
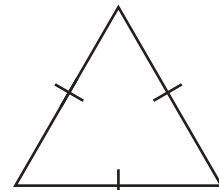
**E****F****G****H**

Write down the letter of the right-angled isosceles triangle.

↓
F or G

(b) **G** [1]

(c) A quadrilateral has

- exactly one line of symmetry and
- each angle is either acute or obtuse.

Draw a possible quadrilateral on this grid.
The dashed line must be the line of symmetry.

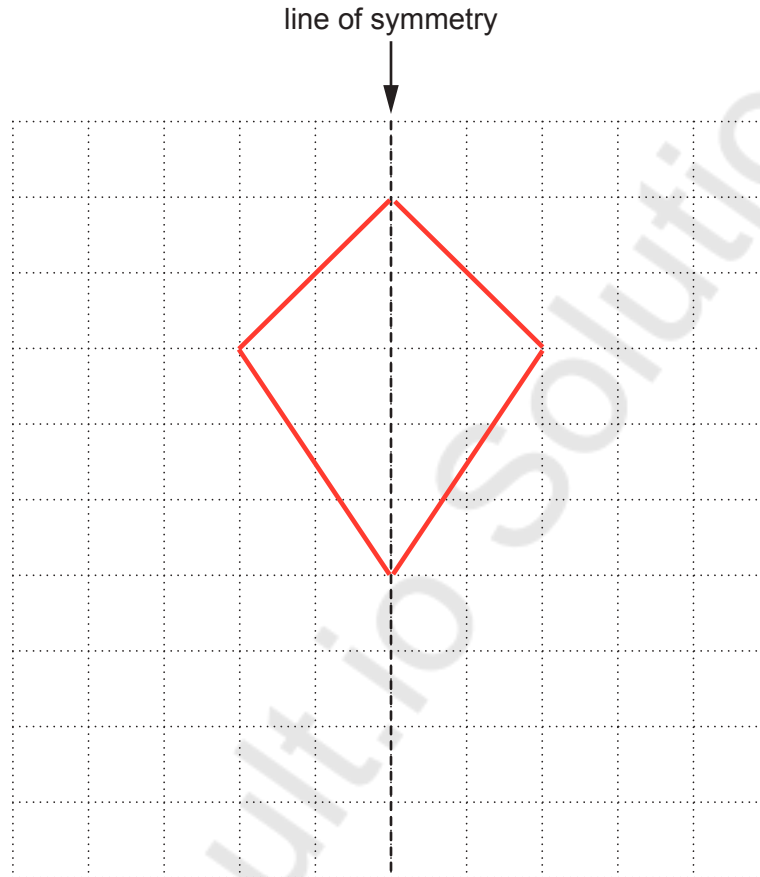

[2]

2 The factors of 6 are 1, 2, 3 and 6.
The factors of 9 are 1, 3 and 9.

(a) Use one of the symbols $<$, $>$ or $=$ to make each statement true.

(i) The number of factors of 6 $>$ the number of factors of 9. [1]

(ii) The lowest factor of 6 $=$ the lowest factor of 9. [1]

(b) Write down the highest common factor (HCF) of 6 and 9.

(b) 3 [1]

- 3 (a) Complete this prime factorisation of 100.
You may not need to use all of the answer lines.

$$100 = 2 \times 2 \times 5 \times 5 \dots\dots\dots$$

.....

.....

$$100 \div 4 = 25$$

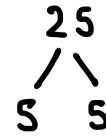

[1]

- (b) A teacher says that the cube root of their favourite number is 5.

Write down the teacher's favourite number.

$$\begin{aligned} 5^3 &= 5 \times 5 \times 5 \\ &= 125 \end{aligned}$$

(b) 125 [1]

- (c) Write $\frac{29}{10^2}$ as a percentage.

$$\frac{29}{100} = 29\%$$

(c) 29 % [1]

- 4 (a) A recipe for biscuits says

Multiply the number of biscuits by 6.25 to find the number of grams of butter needed.

Darcie uses 125 g of butter.

How many biscuits does Darcie make?

$$125 \text{ g} \div 6.25 = 20$$

(a) **20** [2]

- (b) The estimated cost of driving

- an electric car is 68 pence per mile
- a petrol car is 77 pence per mile.

Charlie expects to drive 12 000 miles next year.

Use this information to work out how much money Charlie can expect to save next year if driving an electric car instead of a petrol car.

$$77 - 68 = 9 \text{ p}$$

$$12000 \times 9 \text{ p} = 108000 \text{ p}$$

$$\begin{array}{c} \downarrow \div 100 \\ \text{£}1080 \end{array}$$

(b) £ **1080** [3]

5 This is a one-centimetre square grid.

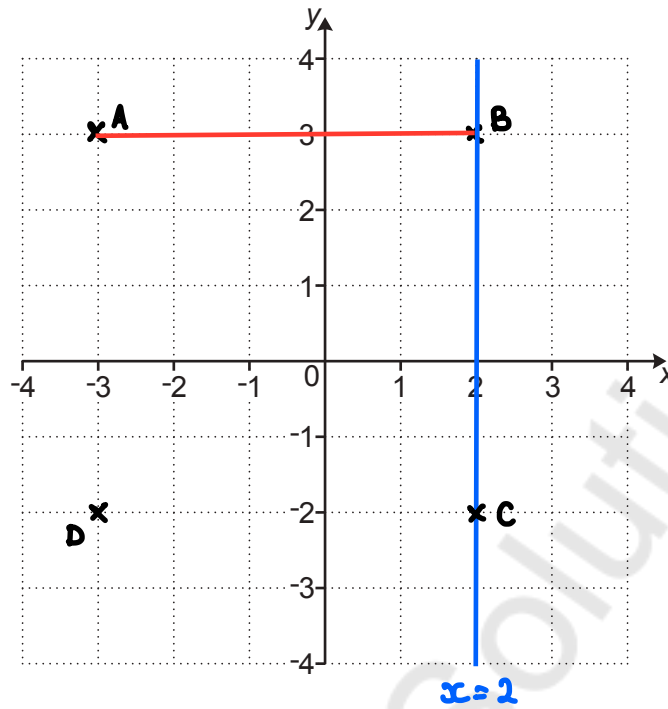

(a) On the grid, plot point A at (-3, 3). [1]

(b) The line AB joins point A to point B.
 Point B is at (2, 3).

Find the length of the line AB.

(b) 5 cm [1]

(c) On the grid, draw the line $x = 2$. [1]

(d) ABCD is a square that fits on the grid.
 Point C is on the line $x = 2$.

Find the coordinates of point D.

(d) D is at (..... -3 , -2) [2]

6 (a) Simplify.

(i) $3a \times 4$

$$3a + 3a + 3a + 3a = 12a$$

(a)(i) $12a$ [1]

(ii) $b \times b \times b \times b$

(ii) b^4 [1]

(iii) $c^2 \times c^4$

$$c^{2+4}$$

(iii) c^6 [1]

(b) Factorise.

$9 - 6y$

$$3(3 - 2y)$$

(b) $3(3 - 2y)$ [1]

7 A student takes two tests.

In Test 1, the student scores 45 out of 60.

Test 2 is also out of 60.

Work out how many marks the student needs in Test 2 to have a mean of 70% in the two tests.

$$60 + 60 = 120 \text{ marks in total}$$

$$0.7 \times 120 = 84$$

$$84 - 45 = 39$$

..... 39 [3]

- 8 (a) Work out the area of this trapezium.

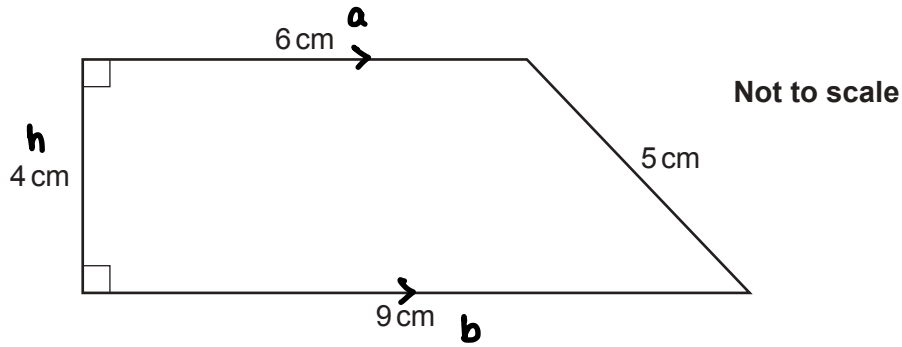

$$\begin{aligned} \text{Area} &= \frac{1}{2}(a + b) \times h \\ &= \frac{1}{2}(6 + 9) \times 4 \\ &= 30 \text{ cm}^2 \end{aligned}$$

(a) **30** cm² [2]

- (b) The circumference of a circle, in terms of π , is 100π cm.

Work out the radius of the circle.

$$\begin{aligned} C &= 2\pi r \\ 100\pi &= 2\pi r \\ \div 2\pi & \quad \quad \quad \div 2\pi \\ 50 &= r \end{aligned}$$

(b) **50** cm [2]

- 9 $\mathcal{U} = \{1, 2, 3, 4, 5, 6, 7, 8, 9, 10, 11, 12, 13\}$
 $T = \{2, 4, 6, 8, 10, 12\}$
 $F = \{5, 10\}$

(a) The elements 1 and 2 have been entered on this Venn diagram.

Complete the Venn diagram to show **all** of the elements.

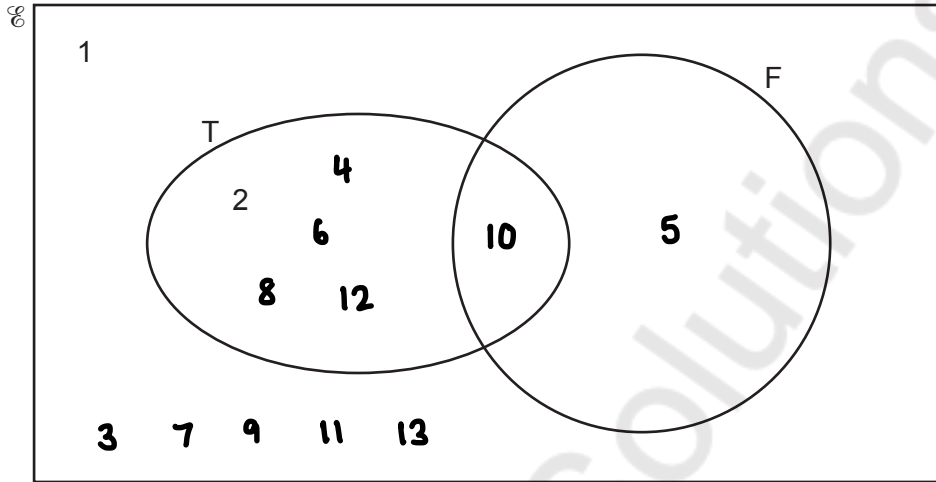

[2]

(b) Finley picks one of the 13 elements in the universal set, \mathcal{U} , at random.

Write down the probability that the element is a member of both set T and set F.

(b) $\frac{1}{13}$ [1]

(c) Sam picks one of the 13 elements in the universal set, \mathcal{U} , at random.

Sam says

The probability the element is in set T is $\frac{6}{13}$.

The probability the element is in set F is $\frac{2}{13}$.

Therefore, the probability the element is in set T or set F is $\frac{6}{13} + \frac{2}{13} = \frac{8}{13}$.

Sam is wrong.

Explain Sam's error and give the correct answer.

Sam's error : Counted 10 twice
 correct answer : $\frac{7}{13}$ [2]

10 (a) Write 18 : 42 as a ratio in its simplest form.

$$\begin{array}{l} \div 6 \quad \div 6 \\ 3 : 7 \end{array}$$

(a) **3** : **7** [2]

(b) In a bag of sweets $\frac{1}{5}$ of the sweets are green.

The rest of the sweets are red.

The ratio of the number of green sweets to the number of red sweets can be written in the form 1 : n .

Find the value of n .

$$\text{Green} = \frac{1}{5}$$

$$\text{Red} = \frac{4}{5}$$

$$\begin{array}{l} G : R \\ 1 : 4 \\ \uparrow \\ n \end{array}$$

(b) $n =$ **4** [2]

(c) A factory has a large order for copper pipe.

The factory has many machines that make the copper pipe.

Each machine makes the same length of copper pipe in a day.

3 machines can make the copper pipe for this order in 25 days.

Find the number of machines needed to make this order in 15 days.

$$\begin{array}{l} 3 \text{ machines} = 25 \text{ days} \\ \times 5 \qquad \qquad \qquad \div 5 \\ 15 \text{ machines} = 5 \text{ days} \\ \div 3 \qquad \qquad \qquad \times 3 \\ 5 \text{ machines} = 15 \text{ days} \end{array}$$

(c) **5** [3]

11 The table shows four pairs of triangles.

For each pair, decide whether the two triangles are mathematically similar. Write each answer, yes or no, in the second column of the table.

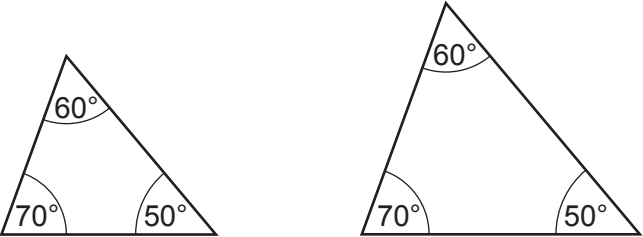
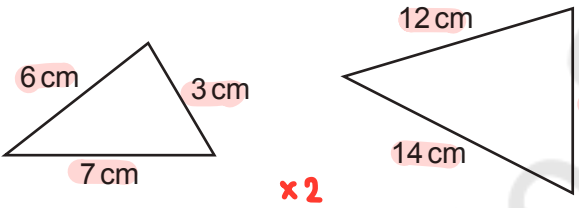
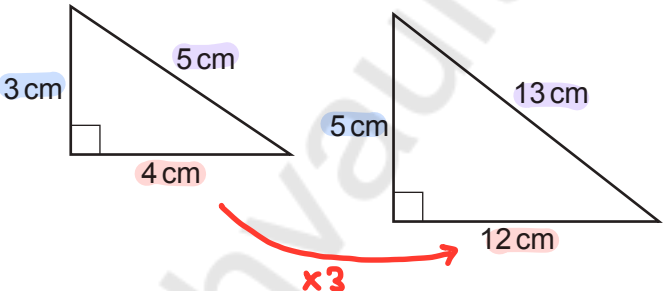
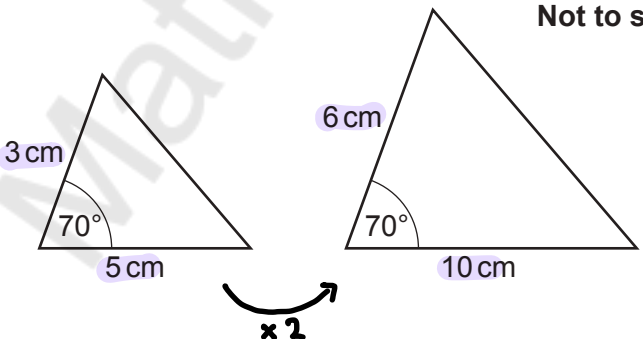
Triangles	Mathematically similar? (yes/no)
<p style="text-align: right;">Not to scale</p> 	<p style="text-align: center;">Yes</p> <p>.....</p>
<p style="text-align: right;">Not to scale</p> 	<p style="text-align: center;">Yes</p> <p>.....</p>
<p style="text-align: right;">Not to scale</p> 	<p style="text-align: center;">No</p> <p>.....</p>
<p style="text-align: right;">Not to scale</p> 	<p style="text-align: center;">Yes</p> <p>.....</p>

[2]

12 A school has 540 students.

This pie chart shows the way that all 540 students travel to the school.

Each student either walked or cycled or travelled by bus or travelled by car.

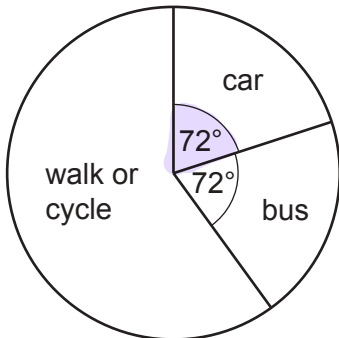

(a) Work out how many of the 540 students travel to the school by car.

$$\frac{72}{360} \times 540 = 108$$

(a) 108 [3]

(b) The number of students who walk is three times the number who cycle.

Work out the sector angle for the students who walk to school.
You do **not** need to draw this on the pie chart.

$$360 - 72 - 72 = 216^\circ$$

Walk : Cycle

$$3 : 1 = 4 \text{ parts}$$

$$216^\circ \div 4 = 54^\circ$$

$$\text{Walk} = 3 \times 54^\circ = 162^\circ$$

(b) 162 ° [3]

- 13 (a) $2a = \sqrt{b}$ where b is a positive integer from 8 to 17.

Given that a is a positive integer, find its value.
You must show your working.

1 4 9 16 25 36

$$b = 9$$

$$2a = \sqrt{9}$$

$$2a = 3$$

$$\div 2 \quad \div 2$$

$$a = 1.5$$

Not an
integer

$$b = 16$$

$$2a = \sqrt{16}$$

$$2a = 4$$

$$\div 2 \quad \div 2$$

$$a = 2$$

✓

(a) $a = \underline{2}$ [2]

- (b) How would your answer to part (a) change if a was only described as an integer?

No change

..... [1]

✓ → positive value

14 (a) Sundip plans to share some money so that

- Mia gets $\frac{1}{2}$
- Sara gets $\frac{2}{5}$
- Nina gets $\frac{1}{7}$.

Will Sundip's plan work?

Give a reason and show working to support your decision.

$$\frac{1}{2} \times 5 + \frac{2}{5} \times 2 = \frac{5}{10} + \frac{4}{10} = \frac{9}{10}$$

$$\frac{9}{10} \times 7 + \frac{1}{7} \times 10 = \frac{63}{70} + \frac{10}{70} = \frac{73}{70}$$

↳ more than 1

..... No because it is greater than 1

..... [2]

(b) Sundip gives Mia and Sara the fractions of the money that she planned.
Mia gets £320.

Work out how much money Sara gets.

$$\text{Mia} = \frac{1}{2} = \text{£}320$$

$$\begin{aligned} \text{Total money} &= 2 \times \text{£}320 \\ &= \text{£}640 \end{aligned}$$

$$\begin{aligned} \text{Sara} &= \frac{2}{5} \times 640 \\ &= 256 \end{aligned}$$

(b) £ 256 [2]

- 15 Alex draws a bar chart to show the age of the young people attending a youth club.

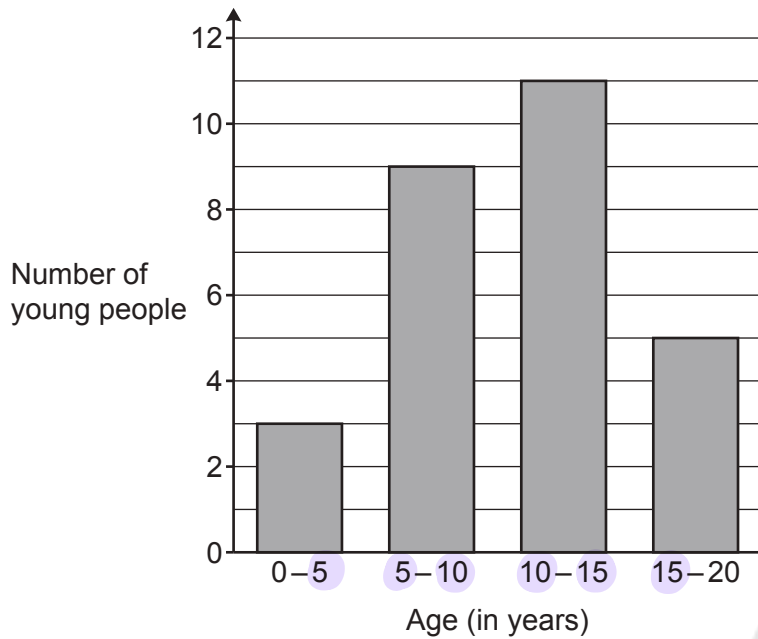

Make **one** criticism of Alex's bar chart.

Age groups overlap.

.....

.....

..... [1]

- 16 (a) Write these numbers in order, starting with the smallest.

2.4×10^2

1.3×10^3

4.9×10^{-1}

9.5×10^1

(a) 4.9×10^{-1} , 9.5×10^1 , 2.4×10^2 , 1.3×10^3 [1]
smallest

- (b) Work out.

$5 \times 10^2 + 4 \times 10^3$

Give your answer in standard form.

4500

4.5×10^3

(b) 4.5×10^3 [2]

17 The number of people watching a football match is 30 000, correct to the nearest thousand.

(a) Complete the error interval for n , the number of people watching the football match.

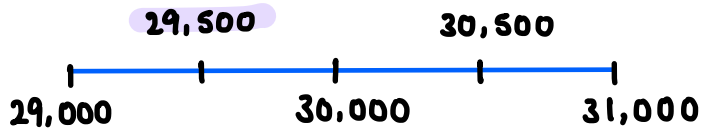

(a) **29 500** $\leq n < 30\,500$ [1]

(b) The number of people watching a rugby match is 30 500, correct to the nearest hundred.

Show that fewer people could be watching the rugby match than the football match. [2]

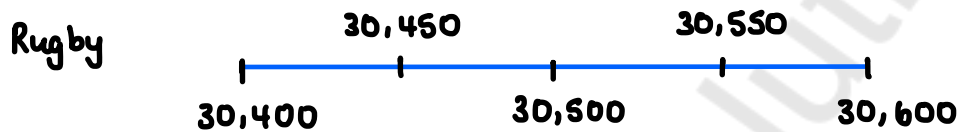

$$30\,450 \leq r < 30\,550$$

Rugby : 30, 450

Football : 30, 460

18 Rearrange this formula to make k the subject.

$$t = 2k - h$$

$$+h \quad +h$$

$$t+h = 2k$$

$$\div 2$$

$$\div 2$$

$$\frac{t+h}{2} = k$$

$$k = \frac{t+h}{2}$$

..... [2]

- 19 A bag contains 150 counters.
The counters are either red or yellow.

- (a) Riley picks a counter from the bag, records its colour, and replaces it.
They do this nine times.

Here are Riley's results.

Red		5
Yellow		4

Use Riley's results to work out how many red counters are likely to be in the bag.

$$p(\text{Red}) = \frac{5}{9}$$

$$\frac{5}{9} \times 150 = 83.3$$

83 or 84

(a) 83 or 84 red counters [3]

- (b) Ling uses the same bag of counters and picks the counters in the same way.

Here are Ling's results.

Red		= 12
Yellow		= 8

Use Ling's results to estimate the probability of choosing a red counter from the bag.
Give your answer as a fraction in its simplest form.

$$p(\text{Red}) = \frac{12}{20} \div 4$$

$$= \frac{3}{5}$$

(b) $\frac{3}{5}$ [2]

- (c) Explain why Ling's results are likely to give a better estimate of the probability of choosing a red counter from the bag than Riley's results.

..... Ling has more results than Riley.

..... [1]

- 20 New cars reduce in value once they have been bought.

Zayn buys a new car for £17 000.
They see this table in a magazine.

Year	Loss in value compared to the start of the year
Year 1	15%
Year 2	10%

Zayn says

According to this table, the value of my car will be £12 750 at the end of Year 2.

Show that Zayn is **not** correct.

[4]

Year 1

$$100\% - 15\% = 85\%$$

$$0.85 \times 17000 = 14450$$

Year 2

$$100\% - 10\% = 90\%$$

$$0.9 \times 14450 = \pounds 13005$$

- 21 The length of a word is classed as short, medium or long depending on the number of characters in the word.

This table shows the percentage, in terms of x , of each word length found in a book.

Length of word	Percentage (%)
Short	$2x + 5$
Medium	$3x - 1$
Long	x

Total **100**

Find the percentage of words in this book which are classed as short words.
You must show your working.

$$2x + 5 + 3x - 1 + x = 100$$

$$6x + 4 = 100$$

$$- 4 \quad - 4$$

$$6x = 96$$

$$\div 6 \quad \div 6$$

$$x = 16$$

$$\text{Short} = 2x + 5$$

$$= 2(16) + 5$$

$$= 37$$

..... **37** % [5]

22 The diagram represents a coastline.

A, B and C are lighthouses.

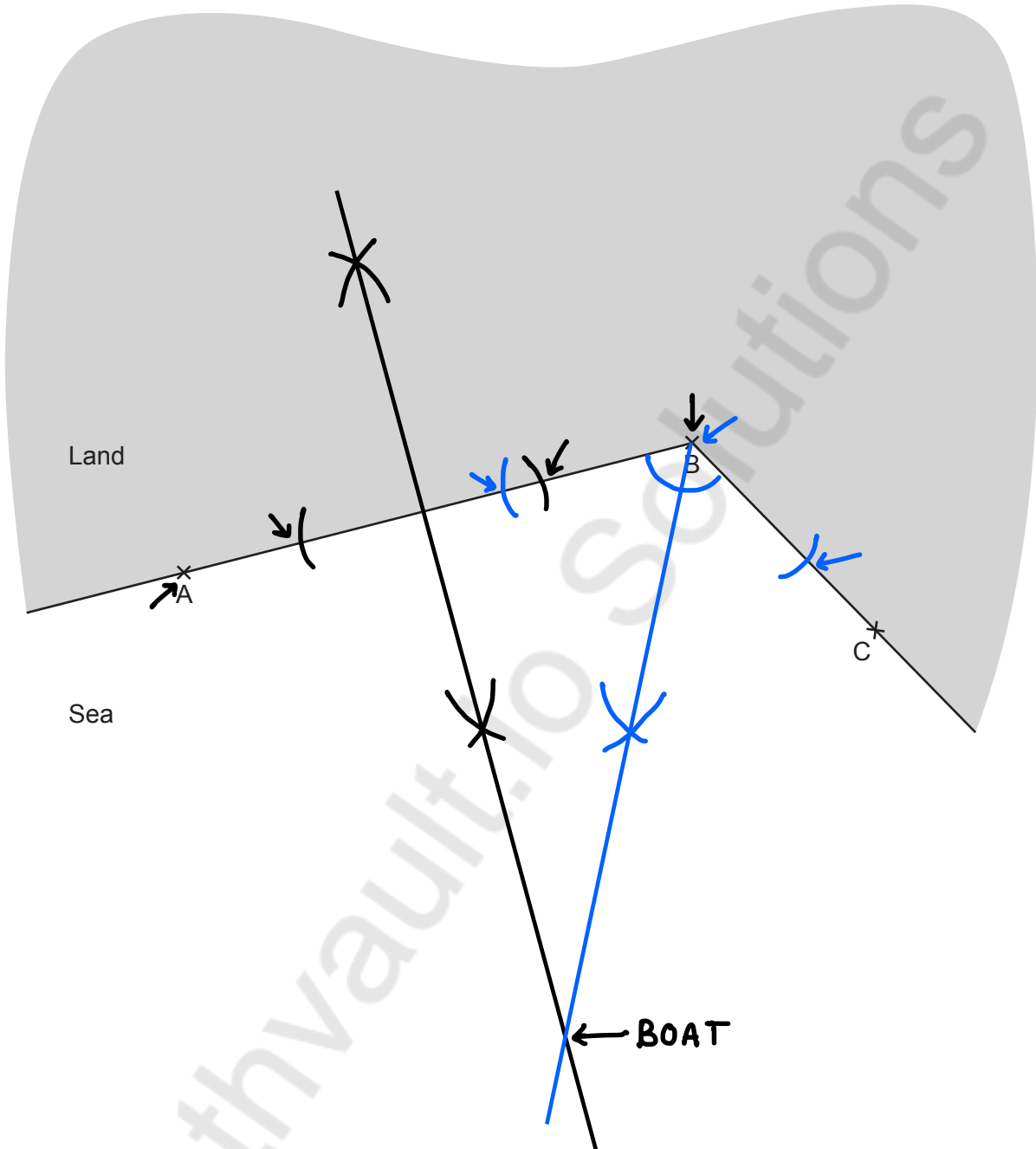

A boat is

- the same distance from A and B **perpendicular bisector**
- the same distance from AB and BC. **angle bisector**

Using a ruler and compasses only, construct the position of the boat.
Label the position of the boat clearly.

[5]

23 At the end of each year, a driver records how many kilometres they have driven.

In 2021, they drove 18% more kilometres than in 2020.

In 2022, they drove 25% more kilometres than in 2020.

In 2022, they drove 3500 km.

(a) Kai says

I can work out how many kilometres were driven in 2020 by reducing 3500 by 25%.
 $3500 \times 0.75 = 2625$ km.

Explain why 2625 is **not** the correct number of kilometres driven in 2020.

$$\begin{array}{rcl} 2022 & 125\% & = 3500 \text{ km} \\ & \div 1.25 & \\ 2020 & 100\% & = 2800 \text{ km} \end{array}$$

..... They should have divided by 1.25

.....

..... [1]

(b) Calculate the number of kilometres driven in 2021.

$$\begin{array}{rcl} 2020 & 2800 \text{ km} & \\ & & \\ 2021 & 100\% + 18\% = 118\% & \\ & 1.18 \times 2800 = 3304 \text{ km} & \end{array}$$

(b) **3304** km [4]

24 The diagram shows the graph of $y = kx - x^2 + 2$, where k is an integer.

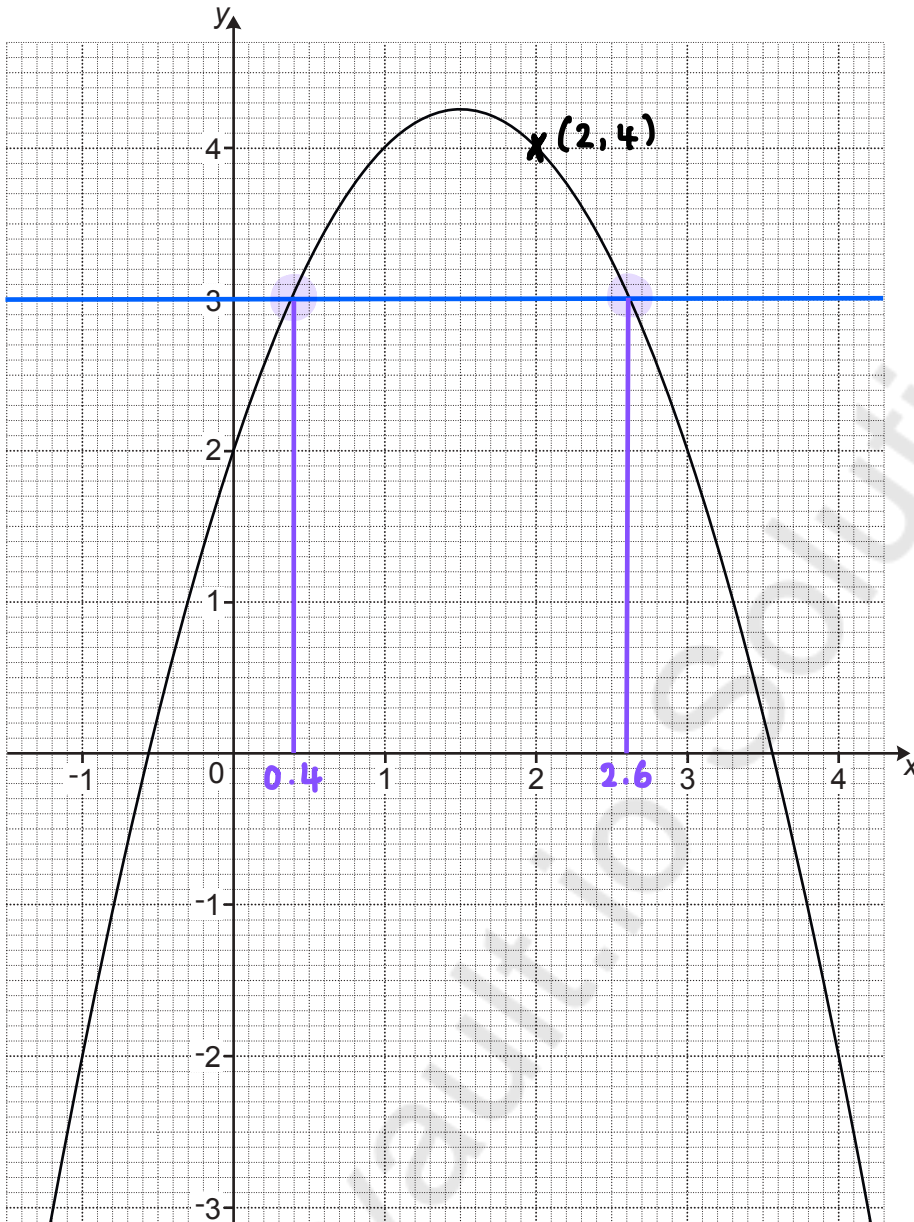

(a) Show that $k = 3$.

[2]

$(2, 4) \quad x = 2 \quad y = 4$

$$y = kx - x^2 + 2$$

$$4 = k(2) - (2)^2 + 2$$

$$4 = 2k - 4 + 2$$

$$4 = 2k - 2$$

$$+2 \qquad +2$$

$$\frac{6}{\div 2} = 2k \div 2 \qquad k = 3$$

(b) Use the graph to solve $3x - x^2 + 2 = 3$.
Give your answers to 1 decimal place.

Draw $y = 3$

(b) $x = \dots\dots 0.4 \dots\dots$ or $x = \dots\dots 2.6 \dots\dots$ [2]

- 25 Taylor designs a logo using isosceles triangles joined at a central point, P.

This is the start of Taylor's design.

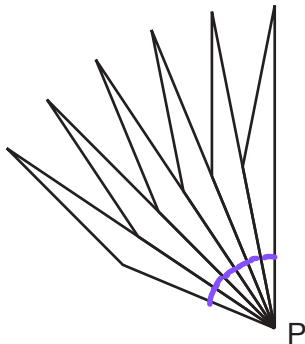

Not to scale

The completed design will have rotational symmetry, order 60 about point P.

Each triangle has base, b , and height, h , measured in mm.

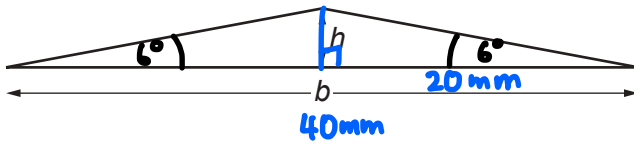

Not to scale

Calculate h when $b = 40$ mm.

Give your answer correct to 1 decimal place.

$$360^\circ \div 60 = 6^\circ$$

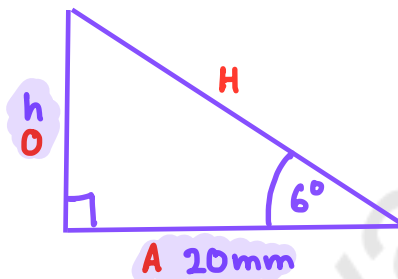

$$\text{SOH CAH TOA}$$

$$\tan \theta = \frac{O}{A}$$

$$\tan(6) = \frac{h}{20}$$

$$\tan(6) \times 20 = h$$

$$h = 2.102084705$$

$$\approx 2.1 \text{ mm}$$

..... 2.1 mm [4]

END OF QUESTION PAPER

