

Surname	Centre Number	Candidate Number
Other Names		0



GCSE

3310U40-1



**MATHEMATICS – NUMERACY
UNIT 2: CALCULATOR-ALLOWED
INTERMEDIATE TIER**

THURSDAY, 8 NOVEMBER 2018 – MORNING

1 hour 45 minutes

ADDITIONAL MATERIALS

A calculator will be required for this paper.
A ruler, a protractor and a pair of compasses may be required.

INSTRUCTIONS TO CANDIDATES

Use black ink or black ball-point pen. Do not use gel pen or correction fluid.
You may use a pencil for graphs and diagrams only.
Write your name, centre number and candidate number in the spaces at the top of this page.
Answer **all** the questions in the spaces provided.
If you run out of space, use the continuation page at the back of the booklet. Question numbers must be given for all work written on the continuation page.
Take π as 3.14 or use the π button on your calculator.

INFORMATION FOR CANDIDATES

You should give details of your method of solution when appropriate.
Unless stated, diagrams are not drawn to scale.
Scale drawing solutions will not be acceptable where you are asked to calculate.
The number of marks is given in brackets at the end of each question or part-question.
In question 4(d), the assessment will take into account the quality of your linguistic and mathematical organisation, communication and accuracy in writing.

For Examiner's use only		
Question	Maximum Mark	Mark Awarded
1.	5	
2.	6	
3.	3	
4.	13	
5.	7	
6.	11	
7.	11	
8.	8	
9.	6	
10.	6	
11.	4	
Total	80	



NOV183310U40101

Formula List – Intermediate Tier

Area of trapezium = $\frac{1}{2}(a + b)h$

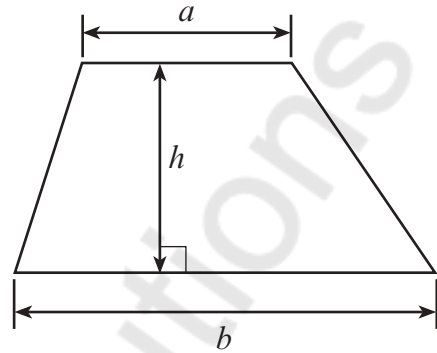

Volume of prism = area of cross-section \times length

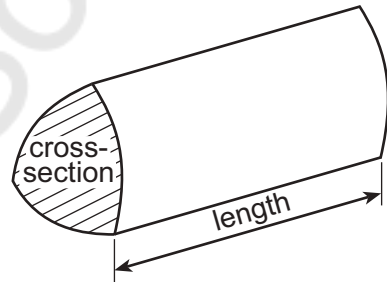

1. (a)

T-shirt	Pair of shoes
 <p>Was £46</p> <p>Now 22% off in the sale</p>	 <p>Was £43.60</p> <p>Now $\frac{3}{8}$ off in the sale</p>

(i) Calculate the sale price of the T-shirt.

[2]

$$\frac{22}{100} \times 46 = 0.22 \times 46$$

$$46 - (0.22 \times 46) = £35.88$$

(ii) Calculate the sale price of the pair of shoes.

[2]

$$43.60 - \left(\frac{3}{8} \times 43.60 \right)$$

$$= £27.25$$

(b) Before the sale, a pair of jeans cost £43.
In the sale, the jeans cost £37.
By what fraction have the jeans been reduced in the sale?
Circle your answer.

[1]

$$43 - 37 = 6 = \frac{6}{43} \times 43$$

$$x = \frac{6}{43}$$



2. Mixing 200 ml of white paint with 10 ml of red paint and 5 ml of blue paint makes light purple paint.

Paint is sold in tins of size 250 ml, 500 ml and 1 litre.

Jana is going to make some light purple paint.
She does not want to have any white, red or blue paint left over.
Jana wants to buy as **few tins of paint as possible**.



She buys a 250 ml tin of blue paint.

How many tins of paint will Jana need to buy altogether?
Complete the table below.

[6]

$$200 : 10 : 5$$

$$40 : 2 : 1$$

250 ml of B

$$\therefore R = 2 \times 250 \times 2 = 500 \text{ ml}$$

$$W = 200 \times 40 = 10000 \text{ ml}$$

Colour of paint	Size of tin	Number of tins
Blue	250 ml	1
Red	500	1
White	1 L	10
		Total number of tins of paint = 12



3. *Airand Electronics* only sells digital tablets and covers.



The Venn diagram shows the number of items sold by *Airand Electronics* during the first week in May.

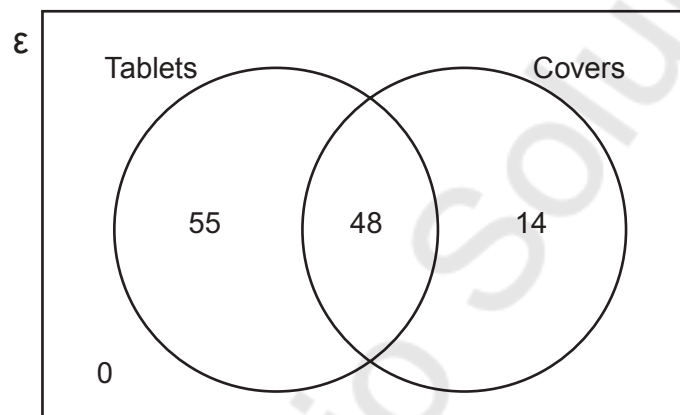

Each tablet was sold for £220.
Each cover was sold for £18.

How much money in total did *Airand Electronics* take in the first week of May?

You must show all your working.

[3]

$$\text{Tablet} = (55 + 48)(220) = \text{£}22660$$

$$\text{Covers} = (48 + 14)(18) = 1116$$

$$\text{Total} = \text{£}23776$$



4. (a) *Rushmoore Energy* is a company that supplies electricity. Last year, *Rushmoore Energy* displayed the following information in a pie chart.

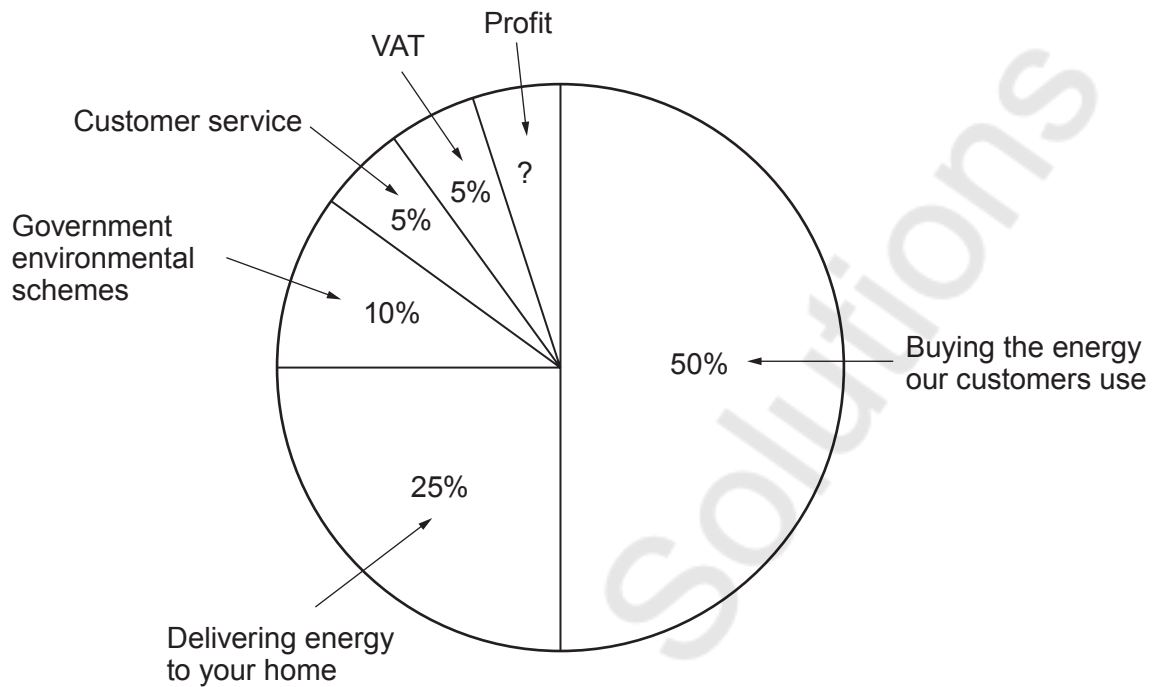

The pie chart represents a total of £9100 million.

How much profit did *Rushmoore Energy* make last year?
Give your answer in millions of pounds.

[3]

$$100 - 95 = 5\% \text{ (Profit)}$$

$$\frac{5}{100} \times 9100 = 455$$

Profit £ 455 million

- (b) Last year, *Rushmoore Energy* had 8.58 million customers. The previous year, *Rushmoore Energy* had 8.21 million customers. How many extra customers were there last year?
Circle your answer.

[1]

37 000 370 000 3 700 000 0.37 37 000 000

$$8.58 \text{ million} - 8.21 \text{ million}$$

$$= 370 000$$



- (c) Maggie looks at the back of her electricity bill.
It shows how much energy she used last period and this period.
This is the display she sees.

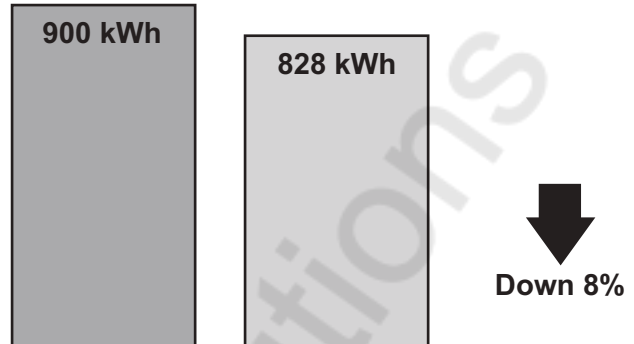

Is this decrease of 8% correct for the reduction in kWh?
You must show all your working to support your answer.

[2]

Yes No Can't tell

$$\frac{900 - 828}{900} \times 100 = 8\%$$



- (d) In this part of the question, you will be assessed on the quality of your organisation, communication and accuracy in writing.

Maggie used 828 kWh of electricity this period.

Electricity was charged at £0.18 per kWh.

The standing charge for this period was £65.

VAT at 5% is payable on the total cost of the electricity used and the standing charge.

Calculate Maggie's electricity bill.

You must show all your working.

[5 + 2 OCW]

$$828 \times 0.18 = £149.04$$

$$\text{Plus standing charge} = 214.04$$

$$\text{VAT} = \frac{5}{100} \times 214.04 = 1.07$$

$$\text{Total} = £227.04$$



5. Zara is paid in dollars.
Last year, Zara's total income before tax was \$25 000.

The tax bands, taxable income and tax rates last year were as follows:

Band	Taxable income	Tax rate
Personal Allowance	Up to \$10 000	0%
Basic rate	\$10 000 to \$22 000	20%
Higher rate	over \$22 000	25%

- (a) Show that Zara should have paid \$2400 tax at the basic rate. [2]

$$\begin{aligned}
 & \text{1st } 10000 \text{ free } 20\% = 15000 - 3000 = 12000 \\
 & 20\% = 25000 - 22000 \\
 & \quad = 3000 \\
 & \quad \frac{20}{100} \times 12000 \\
 & \quad = \$2400
 \end{aligned}$$

- (b) Zara's **total** tax bill last year was \$4000.
She thinks an error has been made.
Calculate how much tax should be refunded to Zara.
You must show all your working. [5]

$$\begin{aligned}
 & 25\% \neq 3000 \\
 & \quad = \$750 \\
 & \text{Total} = 2400 + 750 \\
 & \quad = \$3150 \\
 & \text{Refund} = \$4000 - 3150 \\
 & \quad = \$850
 \end{aligned}$$

Zara's tax refund is \$ 850



6. Emyr has set his lawn mower to work at a constant speed of 2000 m per hour. He walks a distance of 300 m when he cuts his lawn.



- (a) (i) Use this information to calculate how long Emyr takes to cut his lawn. Give your answer in minutes. [2]

$$\frac{300\text{m}}{2000\text{m}} \times 60 = 9\text{mins}$$

$$= 9\text{mins}$$

It takes Emyr 9 minutes.

- (ii) What assumption have you made? [1]

OR He walks in a straight line
He did not stop

- (iii) What impact would this have on the time you calculated in answering (a)(i)? [1]

It could make the time longer

- (b) Emyr cuts his lawn 25 times a year. He uses 4.5 litres of petrol in his lawn mower each year.

How much petrol does the lawn mower use for every 100 metres that Emyr walks? Give your answer in litres. [3]

$$4.5\text{L} \times 25 \times 300\text{m} = 7500\text{m}$$

$$\text{for } 100\text{m} = \frac{4.5 \times 100}{7500} = 0.06\text{L}$$



- (c) Petrol costs £1.30 per litre.

Emyr says,

"The petrol for my lawn mower costs me approximately 60p per pint."

Is Emyr correct?

You must show all your working.

[3]

Yes

No

$$1 \text{ litre} = 1.75 \text{ pints}$$

$$\text{Correct value} = \frac{1.3}{1.75} = \pounds 0.73$$

$$73\text{p} \neq 60\text{p}$$

- (d) Emyr's friend claims that she walks $1\frac{7}{8}$ miles when she cuts her lawn.

Approximately how far is this in metres?

Circle your answer.

[1]

780 metres

1200 metres

2400 metres

3000 metres

3400 metres

$\frac{15}{8}$ miles in metres

$$\frac{15}{8} \times 1600 = 3000 \text{ m}$$



7. *Tube Cycles* makes a large number of bikes each day. The graph shows the number of bikes made on 1st July each year from 2012 to 2017.

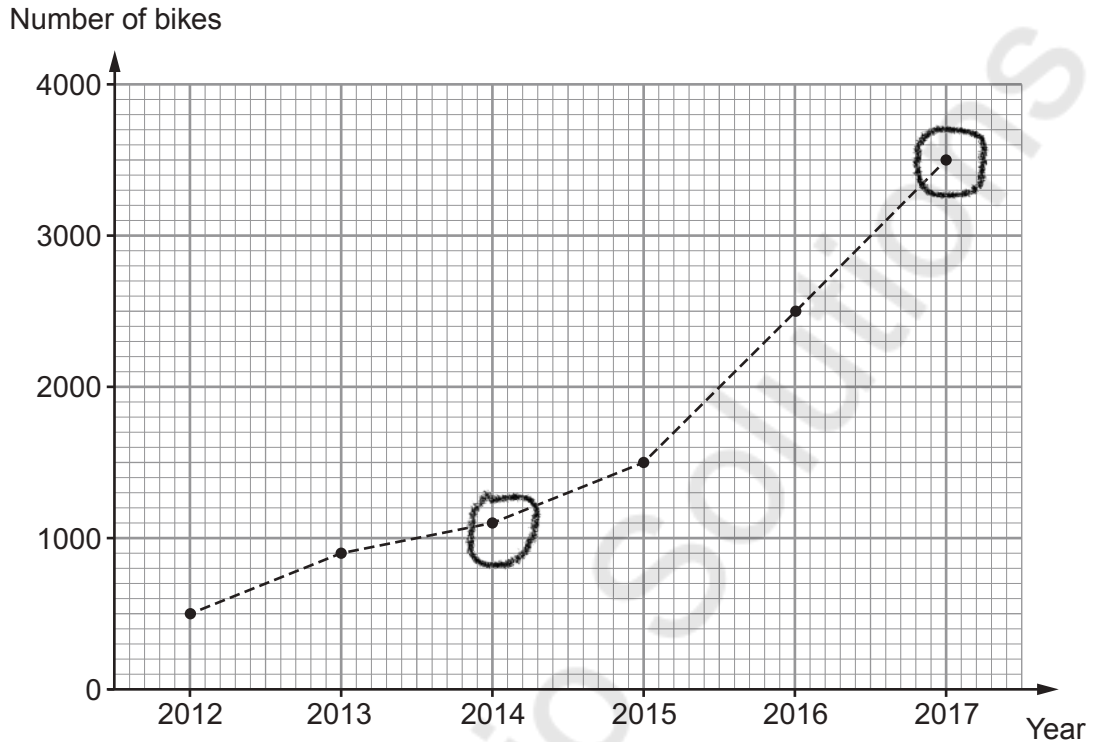

- (a) How many bikes were made on 1st July 2014? Circle your answer. [1]

1010 1020 1050 1100 1200

- (b) From the graph, is it possible to say how many bikes were made on 1st December 2014? You must give a reason for your answer. [1]

No, because the graph does not give data for 1st July

- (c) Complete the statement below. [1]

'On 1st July 2017, there were 7 times as many bikes made than on 1st July 2012.'

$$\frac{3500}{500} = 7$$



- (d) On 1st December 2016, 4000 bikes were made at the *Tube Cycles* factory. The *Tube Cycles* factory was working at 80% capacity on that day. This means that only 80% of the maximum possible number of bikes were made.

When the factory works at 95% capacity, how many bikes are made in one day? [3]

$$80\% = 4000$$

$$\frac{95 \times 4000}{80} = 4750 \text{ cycles}$$

- (e) (i) In October 2018, the manager of the *Tube Cycles* factory recorded the number of bikes made each day. Here are her results.

Number of bikes, b	Frequency
$1000 \leq b < 2000$	3
$2000 \leq b < 3000$	12
$3000 \leq b < 4000$	9
$4000 \leq b < 5000$	7

median
TOTAL = 31

Calculate an estimate of the mean number of bikes made per day during October 2018. [4]

$$\begin{aligned} \text{Midpoints} &= 1500, 2500, 3500, 4500 \\ &= 1500 \times 3 + 2500 \times 12 + 3500 \times 9 \\ &\quad + 4500 \times 7 = 97500. = \frac{97500}{31} = 3145.2 \text{ cycles} \end{aligned}$$

- (ii) Which group contains the **median** number of bikes made per day? Circle your answer.

$1000 \leq b < 2000$

$2000 \leq b < 3000$

$3000 \leq b < 4000$

$4000 \leq b < 5000$

Can't tell

$\frac{31}{2} = 15.5$



8. Amrit and Gareth are planning to go to Switzerland.
The table below shows the rates for exchanging British pounds (£) and Swiss francs (CHF) at a money exchange shop.

Buy Swiss francs (CHF)	£1 buys 1.24 CHF
Sell Swiss francs (CHF)	1.28 CHF buys £1

The exchange shop:

- has all possible British notes and coins,
- sells and buys CHF **notes only** (no coins are available or accepted),
- has 10 CHF, 20 CHF, 50 CHF, 100 CHF, 200 CHF and 1000 CHF notes.



- (a) Amrit has £480 to buy Swiss francs.
Calculate
- the maximum number of Swiss francs that Amrit can buy, and
 - how much, to the nearest penny, this will cost him.
- You must show all your working.

[5]

$$\text{Change to CHF} = 480 \times 1.24 = 590$$

$$\text{Cost for Amrit} = \frac{590}{1.28} = \text{£}475.81$$



- (b) Gareth paid £250 to buy 310 CHF.
Unfortunately, he is now unable to go to Switzerland.
How much will Gareth lose in selling 310 CHF back to buy pounds? [3]

$$\frac{310}{1.28} = \text{£} 242.2$$

$$\begin{aligned} \text{Loss} &= \text{£} 250 - \text{£} 242.2 \\ &= \text{£} 7.8 \end{aligned}$$



9. (a) Luned's tent is in the shape of a triangular prism.
The cross-section of her tent is an isosceles triangle.

She noted a few measurements on a diagram of her tent, as shown below.

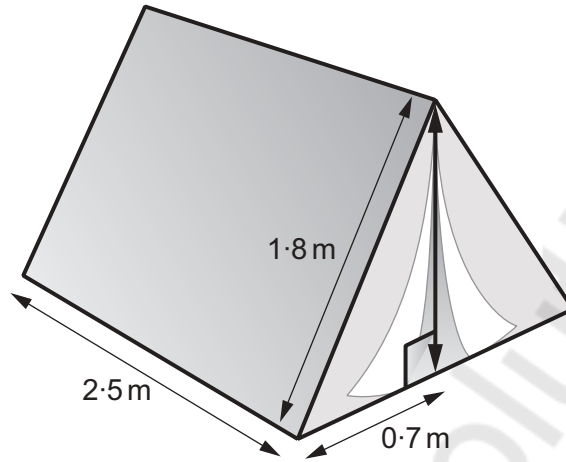

Diagram not drawn to scale

Calculate the volume of Luned's tent.
Give your answer in m^3 .
You must show all your working.

[5]

Pythagoras Theorem: $h^2 = 1.8^2 - 0.7^2$

$h = \sqrt{2.75}$

Volume of Prism = $\frac{1}{2} \times b \times h \times L = \frac{1}{2} \times (0.7 + 0.7) \times 1.7 \times 2.5 = 2.9 \text{ m}^3$

- (b) Which of the following is equal to 0.2 m^3 ?
Circle your answer.

[1]

20 cm^3

200 cm^3

2000 cm^3

200 000 cm^3

2 000 000 cm^3

0.2×1000000



10. Cycle frames are made from steel, aluminium or carbon fibre.
The table below gives the density of steel, aluminium and carbon fibre.

Material	Density (g/cm ³)
Steel	7.8
Aluminium	2.7
Carbon fibre	1.6



Owain has a cycle frame made from aluminium.
His cycle frame has a mass of 9450 g.

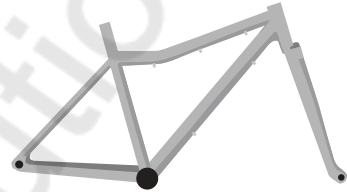

- (a) Calculate the volume of aluminium in Owain's cycle frame.
Give your answer in cm³.

[3]

$$\text{Volume} = \frac{9450}{2.7} = 3500 \text{ cm}^3$$

Volume of aluminium in Owain's cycle frame is 3500 cm³

- (b) Bethan has a cycle frame that is identical to Owain's cycle frame.
However, her cycle frame is made from carbon fibre.
Calculate the mass of this frame.
Give your answer in grams.

[3]

$$\text{Mass} = 1.6 \times 3500 = 5600 \text{ g}$$

Mass of this cycle frame is 5600 g



11. The diagram below is a sketch of the Eiffel Tower.
The sketch is drawn to scale.
The Eiffel Tower is 324 metres tall.
Visitors can climb up to the Level 2 viewing platform using the internal steps.

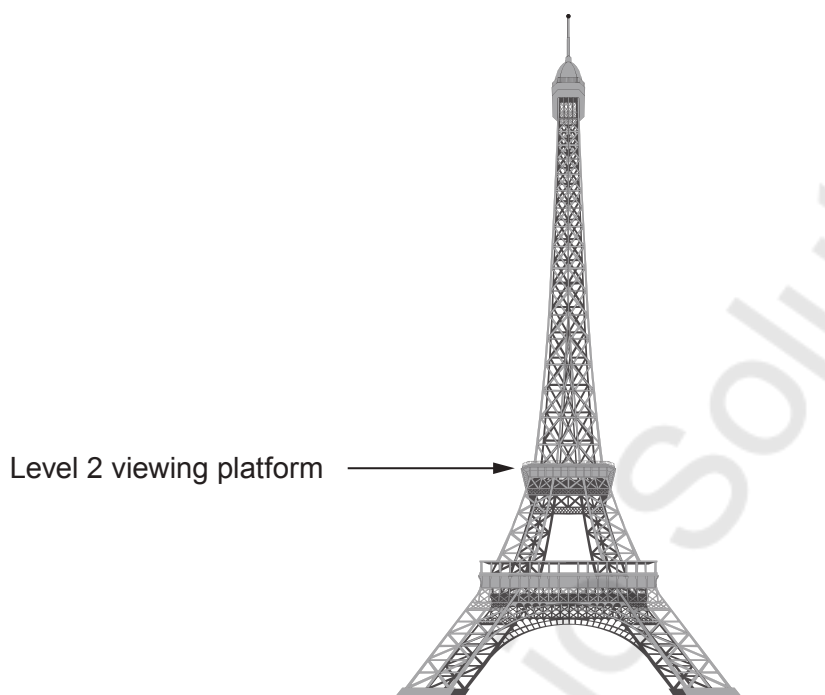

Diagram is drawn to scale

- (a) Which of the following is a reasonable estimate of the number of steps from the ground to the Level 2 viewing platform? [1]

150 650 2500 3500 6500

Level 2 is about $\frac{1}{3}$ of the tower

$$2 \left(\frac{1}{3} \times 324 \text{ to feet} \right) = 648 \text{ steps}$$

$$\approx 650 \text{ steps}$$

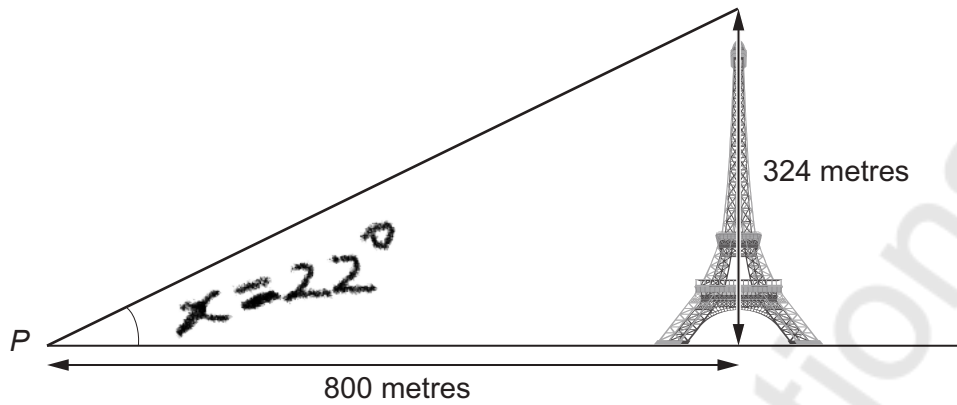

(b)

*Diagram not drawn to scale*Calculate the angle of elevation of the top of the Eiffel Tower from the point P .

[3]

$$x = \tan^{-1}\left(\frac{324}{800}\right)$$

$$= 22.03^\circ$$

$$\approx 22^\circ$$

END OF PAPER



Question number	Additional page, if required. Write the question number(s) in the left-hand margin.
	<p>Mathsvault.io Solutions</p>

Examiner only

