

Surname	Centre Number	Candidate Number
Other Names		0



GCSE

3300U50-1



**MATHEMATICS
UNIT 1: NON-CALCULATOR
HIGHER TIER**

TUESDAY, 21 MAY 2019 – MORNING

1 hour 45 minutes

ADDITIONAL MATERIALS

The use of a calculator is not permitted in this examination.
A ruler, a protractor and a pair of compasses may be required.

INSTRUCTIONS TO CANDIDATES

Use black ink or black ball-point pen. Do not use gel pen or correction fluid.

You may use a pencil for graphs and diagrams only.

Write your name, centre number and candidate number in the spaces at the top of this page.

Answer **all** the questions in the spaces provided.

If you run out of space use the continuation page at the back of the booklet. Question numbers must be given for all work written on the continuation page.

Take π as 3.14.

INFORMATION FOR CANDIDATES

You should give details of your method of solution when appropriate.

Unless stated, diagrams are not drawn to scale.

Scale drawing solutions will not be acceptable where you are asked to calculate.

The number of marks is given in brackets at the end of each question or part-question.

In question 3, the assessment will take into account the quality of your linguistic and mathematical organisation, communication and accuracy in writing.

For Examiner's use only		
Question	Maximum Mark	Mark Awarded
1.	5	
2.	4	
3.	6	
4.	4	
5.	3	
6.	6	
7.	5	
8.	6	
9.	4	
10.	3	
11.	3	
12.	2	
13.	4	
14.	4	
15.	3	
16.	4	
17.	2	
18.	5	
19.	7	
Total	80	



MAY193300U50101

Formula List - Higher Tier

$$\text{Area of trapezium} = \frac{1}{2}(a + b)h$$

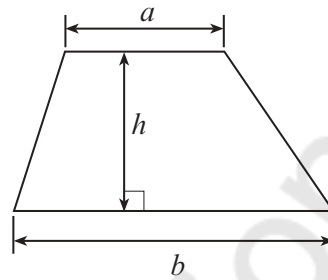

$$\text{Volume of prism} = \text{area of cross-section} \times \text{length}$$

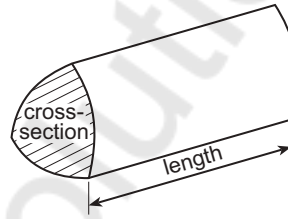

$$\text{Volume of sphere} = \frac{4}{3}\pi r^3$$

$$\text{Surface area of sphere} = 4\pi r^2$$

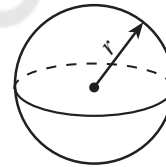

$$\text{Volume of cone} = \frac{1}{3}\pi r^2 h$$

$$\text{Curved surface area of cone} = \pi r l$$

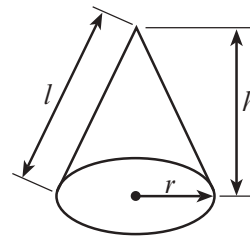

In any triangle ABC

$$\text{Sine rule} \quad \frac{a}{\sin A} = \frac{b}{\sin B} = \frac{c}{\sin C}$$

$$\text{Cosine rule} \quad a^2 = b^2 + c^2 - 2bc \cos A$$

$$\text{Area of triangle} = \frac{1}{2}ab \sin C$$

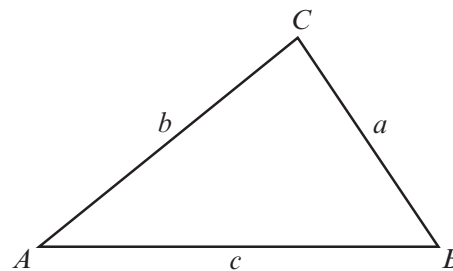

The Quadratic Equation

The solutions of $ax^2 + bx + c = 0$ where $a \neq 0$ are given by
$$x = \frac{-b \pm \sqrt{(b^2 - 4ac)}}{2a}$$

Annual Equivalent Rate (AER)

AER, as a decimal, is calculated using the formula $\left(1 + \frac{i}{n}\right)^n - 1$, where i is the nominal interest rate per annum as a decimal and n is the number of compounding periods per annum.



1. (a) Express 315 as a product of its prime factors in index form. [3]

$$\begin{array}{r}
 \text{LCM} \quad 3 \mid 315 \\
 \quad \quad 3 \mid 105 \\
 \quad \quad 5 \mid 35 \\
 \quad \quad 7 \mid 7 \\
 \quad \quad \quad 1 \\
 \\
 = 3 \times 3 \times 5 \times 7 \\
 = 3^2 \times 5 \times 7
 \end{array}$$

- (b) What is the Highest Common Factor (HCF) of 315 and 42? [2]

$$\begin{array}{r}
 \text{HCF} \quad 3 \mid 315, 42 \\
 \quad \quad 7 \mid 105, 14 \\
 \quad \quad \quad 15, 2 \\
 \\
 = 3 \times 7 \\
 = 21
 \end{array}$$



2. Complete the table below.
 Draw the graph of $y = 3x^2 - 25$ for values of x between -3 and 4 .
 Use the graph paper below.
 You must choose a suitable scale for the y -axis.

[4]

x	-3	-2	-1	0	1	2	3	4
$y = 3x^2 - 25$	2	-13	-22	-25	-22	-13	2	23

$$3(-2)^2 - 25$$

$$12 - 25$$

$$= -13$$

32

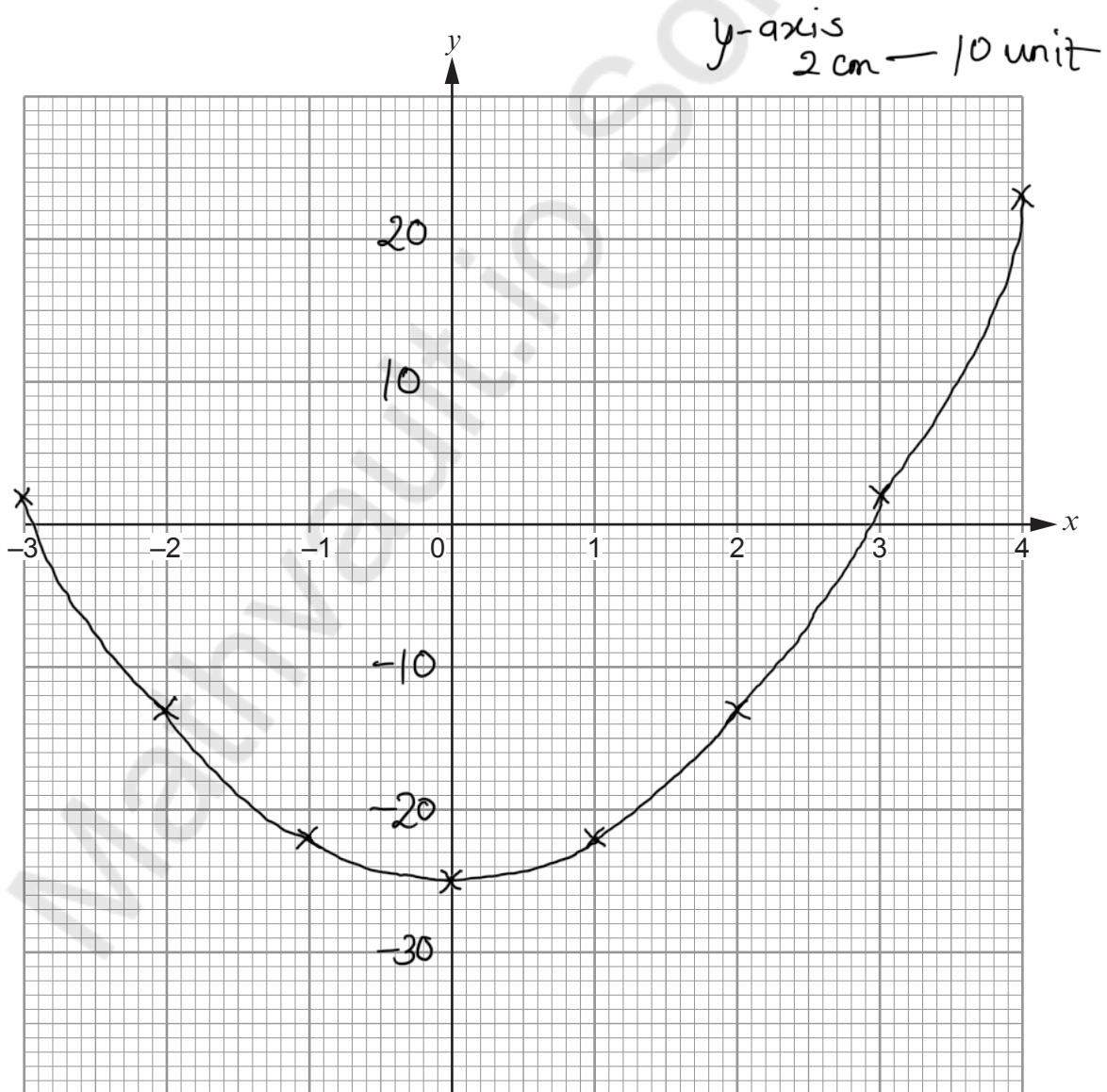

3. In this question, you will be assessed on the quality of your organisation, communication and accuracy in writing.

A **regular** octagon with centre O is shown below.

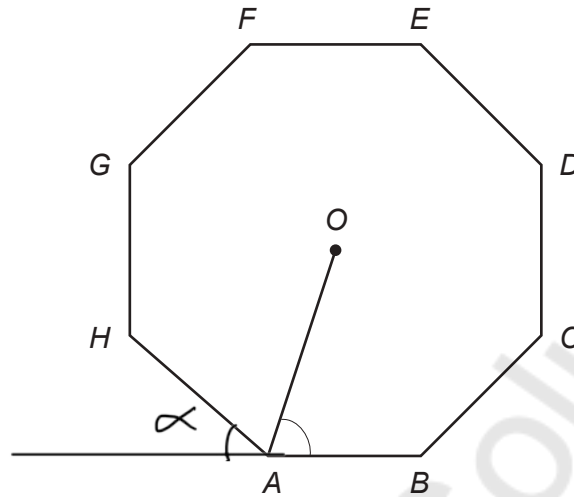

Diagram not drawn to scale

Calculate the exact size of \hat{OAB} .

You may choose to draw additional lines on the diagram to help you.
You must show all your working.

[4 + 2 OCW]

$$\text{Exterior angle} = \frac{360}{8} = 45^\circ$$

$$\hat{OAB} = \frac{180 - 45}{2}$$

$$= \frac{135}{2}$$

$$\hat{OAB} = 67.5^\circ$$



4. The point P is such that:

- P lies on the perpendicular bisector of the line AB ,
- $\hat{BAP} = 30^\circ$.

Using only a ruler and a pair of compasses, show one of the possible positions of P .
All construction lines and arcs must be shown.

[4]

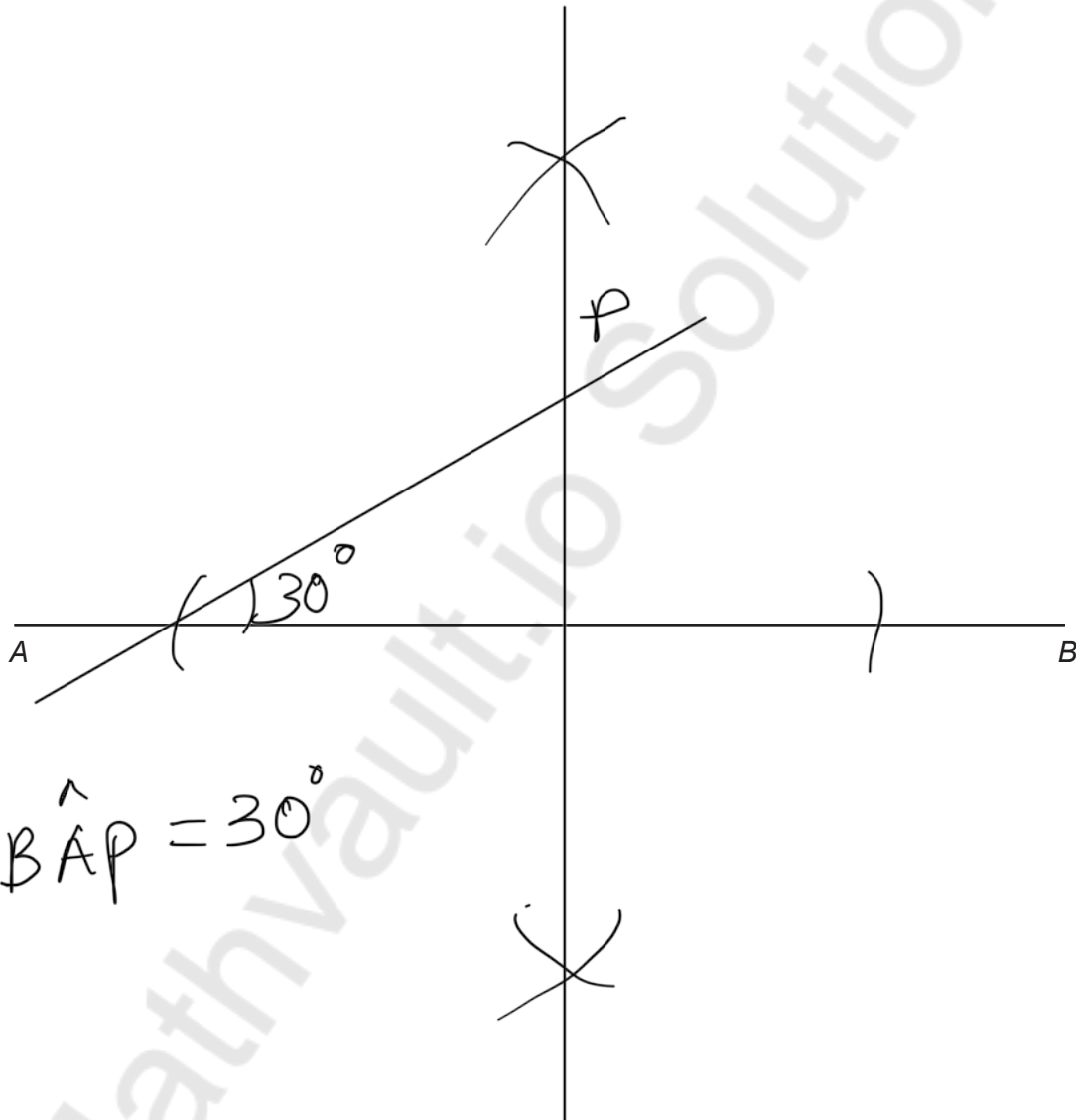

5. Estimate the value of

$$\frac{30.21 \times 1.98^3}{0.49}$$

[3]

$$\begin{array}{l} \underline{30 \times 2^3} \\ 0.5 \\ \underline{630 \times 8} = \underline{48} \\ 0.5 \quad 0.1 \quad 0.1 \\ = 480 \end{array}$$



6. The Anglesey Show is a two-day event held every August.

(a) On the first day, a random sample of 2000 visitors at the show were asked:

Do you live on Anglesey?

640 of them answered 'Yes'.

What was the relative frequency of those who answered 'Yes'?
Give your answer as a decimal.

[1]

$$\frac{640}{2000} = 0.32$$

(b) On the second day a random sample of 3000 visitors at the show were asked the same question.

The relative frequency of those who answered 'Yes' on this day was 0.42.

Calculate the relative frequency of those who said they lived on Anglesey when the samples for **both** days were combined.

Give your answer as a decimal.

[4]

$$\begin{aligned} 3000 \times 0.42 &= 1260 \\ \frac{640 + 1260}{2000 + 3000} &= \frac{1900}{5000} \\ &= 0.38 \end{aligned}$$

(c) Which of the following is most likely to give the best estimate for the relative frequency of visitors to the show living on Anglesey?

Circle your answer.

Your answer
to part (a)

0.42

Your answer
to part (b)

You **must** give an explanation for your choice.

[1]

there were more people sampled
in part b



$$\frac{10}{2} = 5$$

Examiner
only

7. (a) (i) A mass is written as 430 kg, correct to the nearest 10 kg.
Circle the **least** possible value of this mass.

$$430 - 5$$

[1]

420 kg

425 kg

429.5 kg

426 kg

424.9 kg

- (ii) A time period is written as 22 seconds, correct to the nearest second.
Circle the **least** possible value of this time period.

$$22 - \frac{1}{2} = 21.5$$

[1]

22 s

20 s

21 s

21.5 s

21.4 s

- (iii) A population is written as 85 people, correct to the nearest five people.
Circle the **least** possible value of this population.

$$85 - \frac{5}{2} = 83$$

[1]

83 people

81 people

84 people

82 people

80 people

- (b) Calculate $(3.4 \times 10^{-5}) \times 700$.
Give your answer in standard form.

[2]

$$\begin{aligned} & 3.4 \times 10^{-5} \times 7 \times 10^2 \\ & 3.4 \times 7 \times 10^{-5+2} \\ & 23.8 \times 10^{-3+1} \\ & = 2.38 \times 10^{-2} \end{aligned}$$



8. Leah is visiting Cardiff.
The probability that she will go on a tour bus is 0.3.
The probability of Leah seeing a show at the Millennium Centre is independent of her going on a tour bus.

The probability that she goes on a tour bus and sees a show at the Millennium Centre is 0.24.

- (a) Complete the following tree diagram. [4]

$$1 - 0.3 = 0.7$$

$$0.3 \times x = 0.24$$

$$x = \frac{0.24}{0.3} = 0.8$$

$$1 - 0.8 = 0.2$$

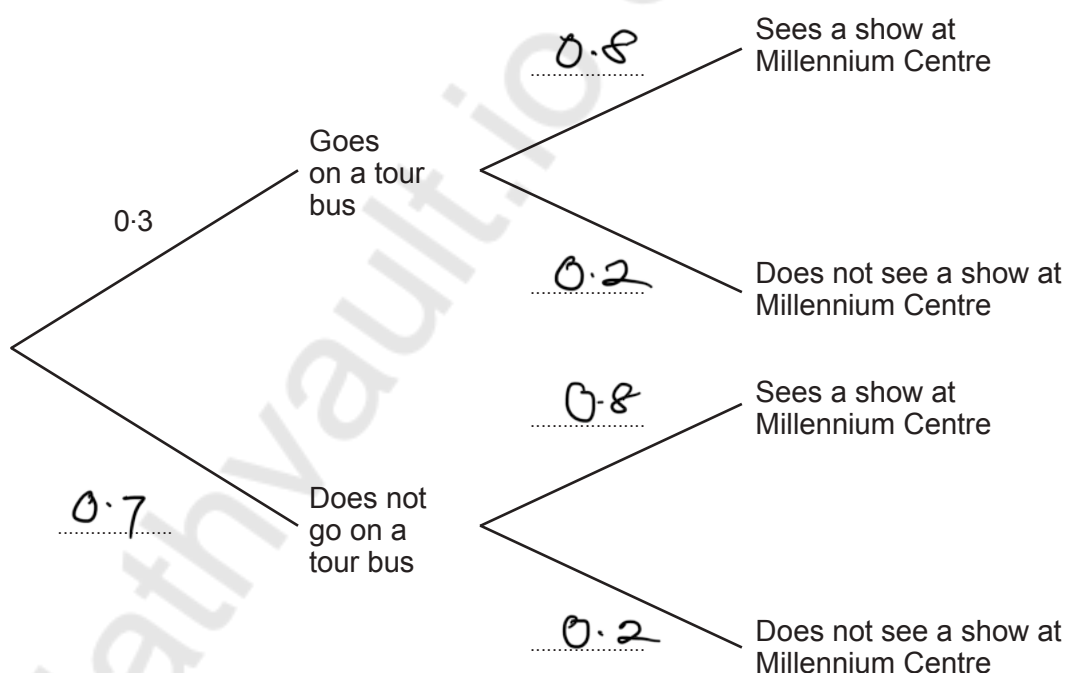

- (b) Calculate the probability that Leah does not go on a tour bus and does not see a show at the Millennium Centre. [2]

$$0.7 \times 0.2 \\ = 0.14$$



9. Arthur, Sian and Kezia are all given some £1 coins.

Arthur receives £ n .

Sian is given five times as much money as Arthur.

Kezia receives three times as much money as Arthur, plus an extra £7.

Sian was given less money than Kezia.

- (a) Write down an inequality in terms of n that illustrates the fact that Sian received less money than Kezia. [2]

$$\text{Arthur} - n, \text{Sian} - 5n, \text{Kezia} - 3n + 7$$

$$5n < 3n + 7$$

- (b) What was the greatest amount of money that Arthur could have been given? [2]

$$5n < 3n + 7$$

$$5n - 3n < 7$$

$$2n < 7$$

$$n < \frac{7}{2} \text{ or } 3.5$$



10. Using the axes below, find the region which satisfies the following inequalities.

$$\begin{aligned}x &\geq -2 \\y + x &\leq 1 \\2y &\geq x\end{aligned}$$

Make sure that you clearly indicate the region that represents your answer.

[3]

$x \geq -2$	$y + x \leq 1$	$2y \geq x$	$y = \frac{x}{2}$
$x = -2$	$y + x = 1$	$2y = x$	
$(-2, 0)$	$y = 1 - x$	$y = 0, x = 0$	$(0, 0)$ $(2, 1)$
	$(0, 1)$ $(1, 0)$		

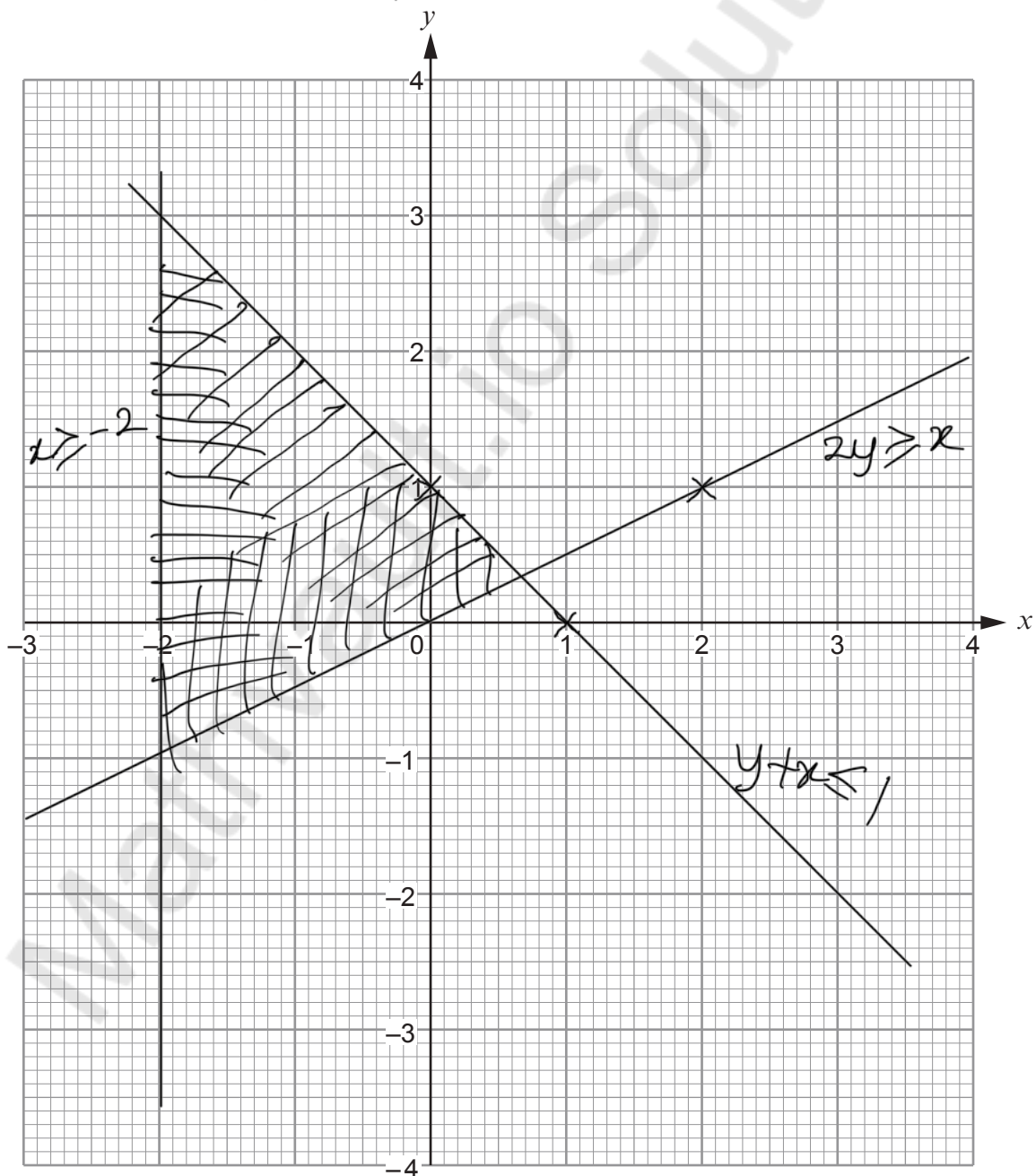

11. Rearrange the following formula to make x the subject. [3]

$$cx - 3 = 4x + d$$

$$cx - 4x = d + 3$$

$$x(c - 4) = d + 3$$

$$x = \frac{d + 3}{c - 4}$$



12. In the following diagram, AE and BD are straight lines and $BC = CE$.

Is it possible to conclude that triangles ABC and DEC are congruent?
You must show all your working and explain your decision.

[2]

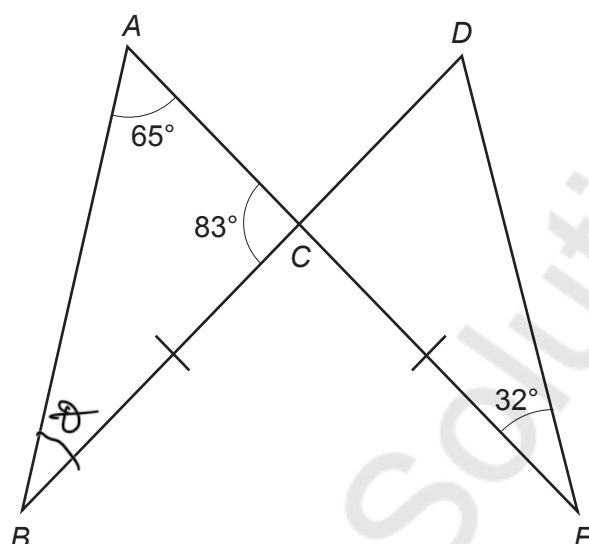

Diagram not drawn to scale

$$\theta = 180 - (65 + 83)$$

$$180 - 148$$

$$\theta = 32^\circ$$

$$\hat{A}BC = \hat{C}ED$$

both triangles are congruent



13. (a) Express $0.\dot{2}48$ as a fraction. [2]

$$0.\dot{2}4888\dots$$

$$100x = 24.888\dots \quad \text{--- ①}$$

$$1000x = 248.88\dots \quad \text{--- ②}$$

Subtract equation ① from ②

$$1000x - 100x = 248.88\dots - 24.888\dots$$

$$900x = \frac{224}{100}$$

$$x = \frac{224}{900}$$

$$x = \frac{56}{225}$$

$$\frac{56}{225}$$

- (b) Evaluate $\left(\frac{1}{27}\right)^{-\frac{2}{3}}$. [2]

$$\left(\frac{1}{27}\right)^{-\frac{2}{3}} = (27)^{2 \times \frac{1}{3}}$$

$$= \sqrt[3]{27^2} = 3^2$$

$$= 9$$



14. The points A , B and C lie on the circumference of a circle.
The straight lines EBD and ECF are tangents to the circle.
 $\hat{BEC} = 58^\circ$ and $\hat{BCA} = 35^\circ$.

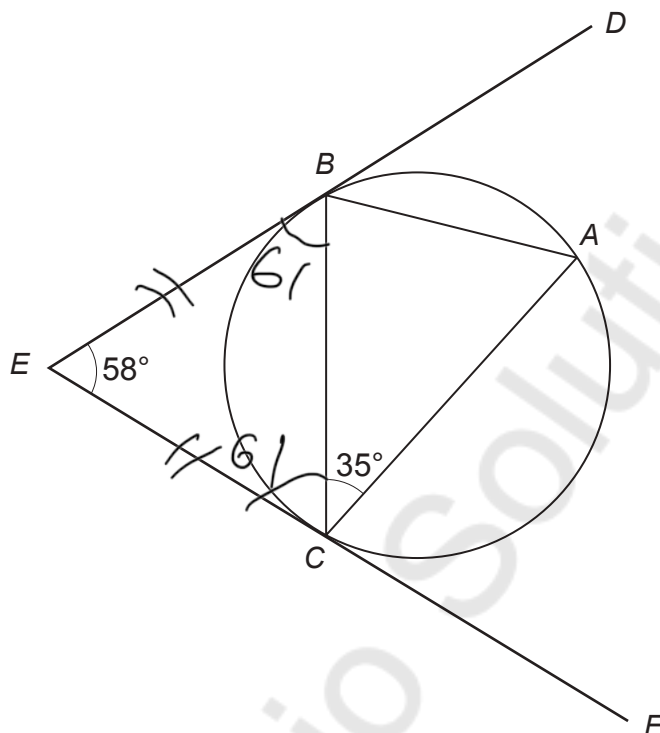

Diagram not drawn to scale

Find the size of \hat{ABC} .
You must show all your working.

[4]

$$\begin{aligned} \hat{EBC} &= 180 - 58 \\ &= \frac{132}{2} \end{aligned}$$

$$\begin{aligned} \hat{ABC} &= 61^\circ \\ \hat{ABC} &= 180 - (61 + 35) \\ &= 84^\circ \end{aligned}$$



15. (a) Simplify $\sqrt{45}$.
Circle your answer.

$$\sqrt{9} \times \sqrt{5} = 3\sqrt{5}$$

[1]

$$\textcircled{3\sqrt{5}}$$

$3\sqrt{15}$

$5\sqrt{3}$

$9\sqrt{5}$

22.5

- (b) Evaluate $(2\sqrt{7} - \sqrt{3})^2$.
Simplify your answer.

[2]

$$(2\sqrt{7} - \sqrt{3})(2\sqrt{7} - \sqrt{3})$$

$$2\sqrt{7}(2\sqrt{7} - \sqrt{3}) - \sqrt{3}(2\sqrt{7} - \sqrt{3})$$

$$(4 \times 7) - 2\sqrt{21} - 2\sqrt{21} + 3$$

$$28 - 4\sqrt{21} + 3$$

$$= 31 - 4\sqrt{21}$$



16. The diagram shows a cylinder.
The cylinder has a base of radius r and a height of $\frac{r}{6}$.

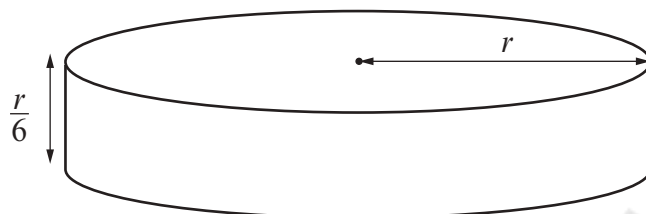

Diagram not drawn to scale

A sphere has radius R .

The volume of the sphere is equal to the volume of the cylinder.

Find R in terms of r .

Give your answer in its simplest form.

[4]

$$\frac{4}{3}\pi R^3 = \pi r^2 h$$

$$\frac{4\pi R^3}{3} = \pi r^3$$

$$8\pi R^3 = \pi r^3$$

$$R^3 = \frac{\pi r^3}{8\pi}$$

$$R = \sqrt[3]{\frac{r^3}{8}} = \sqrt[3]{\frac{1}{8}} \cdot \sqrt[3]{r^3}$$

$$R = \frac{r}{2}$$



17. (a) The following diagram shows a sketch of the curve $y = f(x)$.

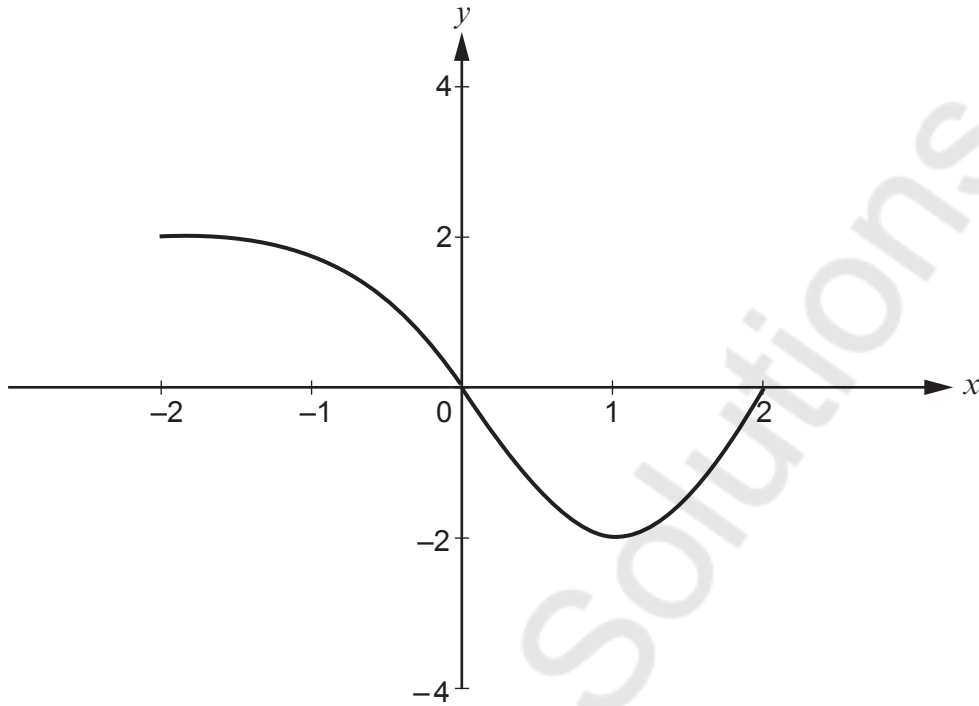

The curve is transformed, as shown below.

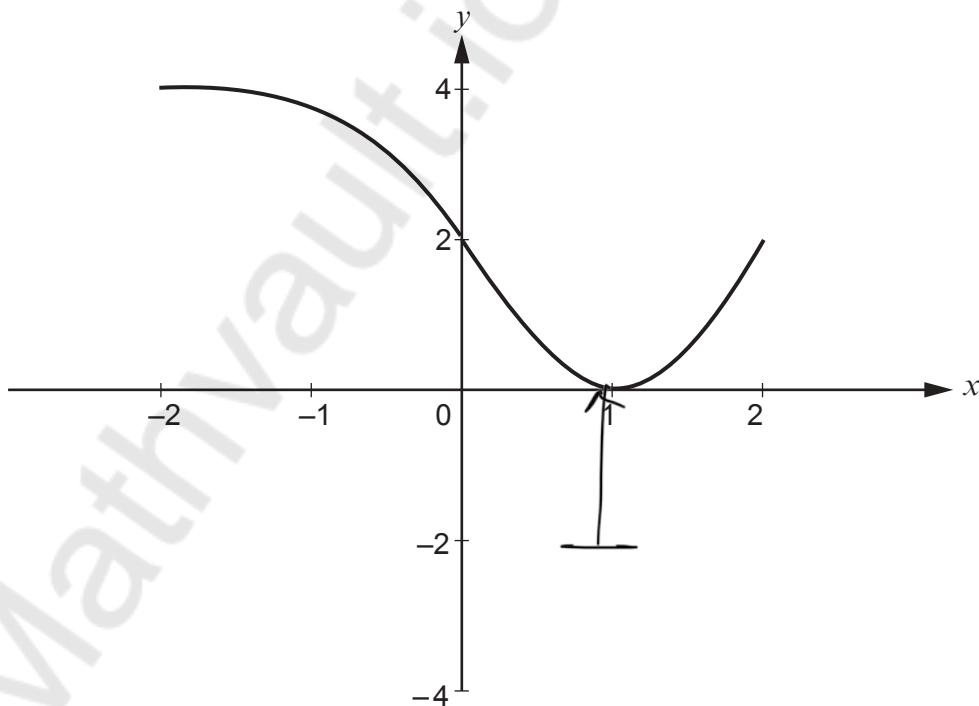

Using function notation, complete the equation of the transformed curve. [1]

$$y = \dots\dots\dots f(x) + 2$$



(b) The following diagram again shows a sketch of the curve $y = f(x)$.

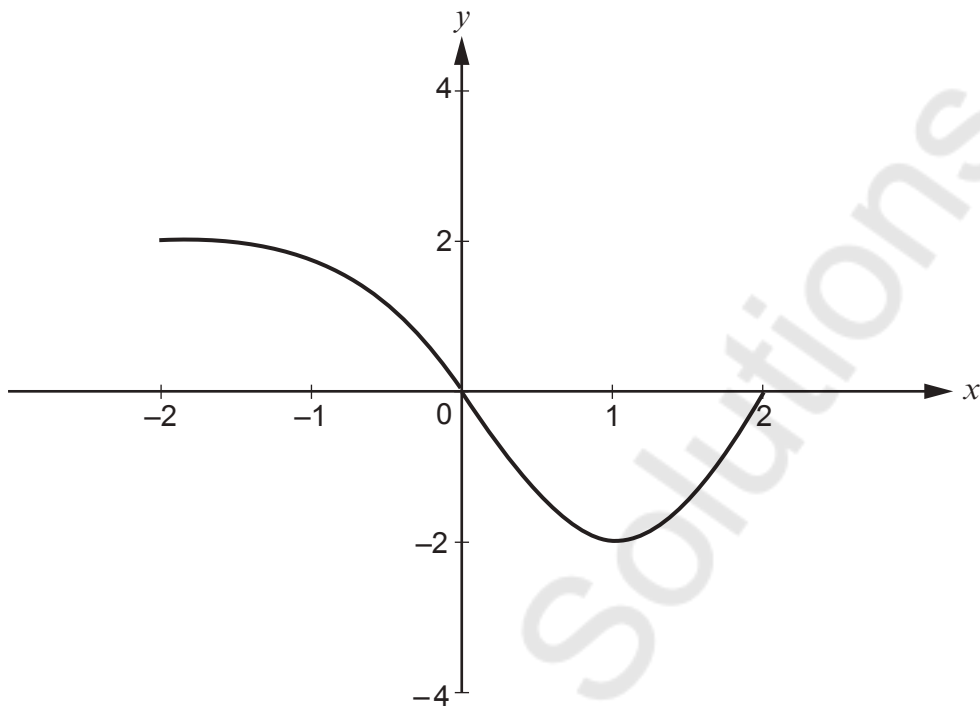

The curve is transformed, as shown below.

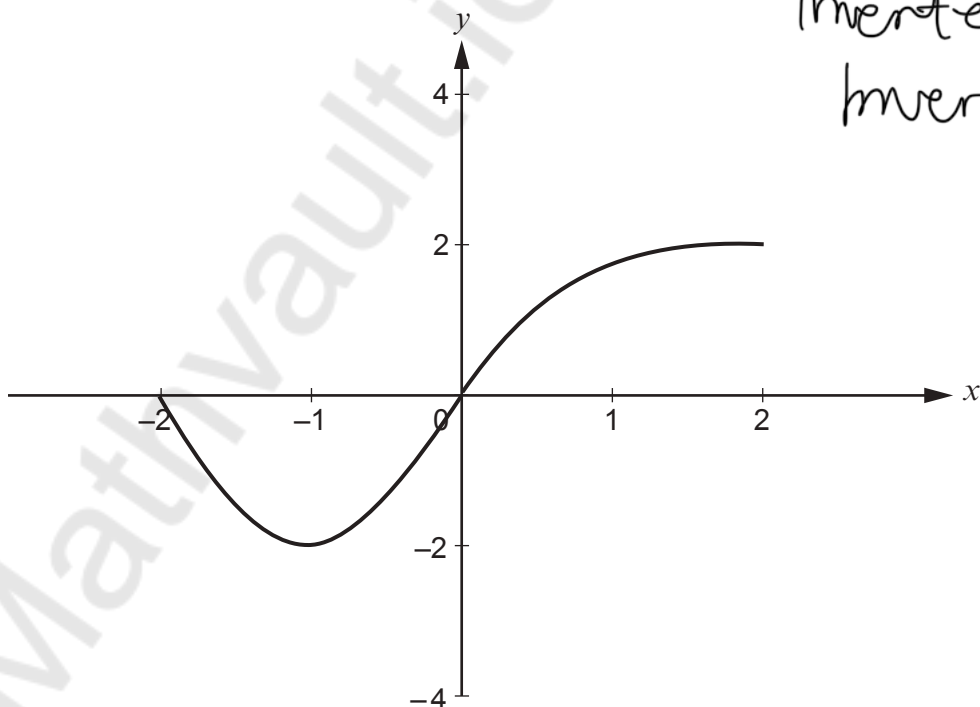

Inverted or
Inverse

Using function notation, complete the equation of the transformed curve.

[1]

$y = \dots\dots\dots f(-x) \dots\dots\dots$



18. A box contains 4 yellow cards and 6 red cards.
Three cards are chosen at random, one at a time, without replacement.

- (a) Calculate the probability that the first two cards are yellow and the third card is red.
You must show all your working. [2]

$$\frac{4}{10} \times \frac{3}{9} \times \frac{6}{8} = \frac{1}{10}$$

- (b) Calculate the probability that at least one yellow card is chosen. [3]

1 - probability 3 red cards
one chosen

$$1 - \left(\frac{6}{10} \times \frac{5}{9} \times \frac{4}{8} \right)$$

$$= \frac{600}{720}$$

$$= \frac{5}{6}$$



19. (a) Write the following expression as a single fraction.
Give your answer in its simplest form. [2]

$$\frac{1}{x-a} - \frac{1}{x}$$

$$\frac{x - x + a}{x(x-a)}$$

$$= \frac{a}{x(x-a)}$$

- (b) Solve the following equation. [5]

$$\frac{x-1}{x(4x+3)} + 2 = 0$$

$$\frac{x-1}{x(4x+3)} = -2$$

$$x-1 = -2x(4x+3)$$

$$x-1 = -8x^2 - 6x$$

$$8x^2 + 6x + x - 1 = 0$$

$$8x^2 + 7x - 1 = 0$$

$$(8x-1)(x+1) = 0$$

$$8x-1=0 \text{ or } x+1=0$$

$$x = \frac{1}{8} \text{ or } x = -1$$



Question number	Additional page, if required. Write the question number(s) in the left-hand margin.
	<p>Mathsvault.io Solutions</p>

Examiner only

