

Surname	Centre Number	Candidate Number
First name(s)		0



**GCSE**

3300U30-1



A20-3300U30-1

**MONDAY, 9 NOVEMBER 2020 – MORNING**

**MATHEMATICS  
UNIT 1: NON-CALCULATOR  
INTERMEDIATE TIER**

1 hour 45 minutes

**ADDITIONAL MATERIALS**

The use of a calculator is not permitted in this examination.  
A ruler, protractor and a pair of compasses may be required.

**INSTRUCTIONS TO CANDIDATES**

Use black ink or black ball-point pen. Do not use gel pen or correction fluid.

You may use a pencil for graphs and diagrams only.

Write your name, centre number and candidate number in the spaces at the top of this page.

Answer **all** the questions in the spaces provided.

If you run out of space, use the additional page at the back of the booklet. Question numbers must be given for all work written on the additional page.

Take  $\pi$  as 3.14.

**INFORMATION FOR CANDIDATES**

You should give details of your method of solution when appropriate.

Unless stated, diagrams are not drawn to scale.

Scale drawing solutions will not be acceptable where you are asked to calculate.

The number of marks is given in brackets at the end of each question or part-question.

In question **8**, the assessment will take into account the quality of your linguistic and mathematical organisation, communication and accuracy in writing.

For Examiner's use only		
Question	Maximum Mark	Mark Awarded
1.	4	
2.	4	
3.	6	
4.	3	
5.	4	
6.	3	
7.	3	
8.	6	
9.	5	
10.	3	
11.	5	
12.	3	
13.	4	
14.	6	
15.	3	
16.	5	
17.	6	
18.	4	
19.	3	
<b>Total</b>	<b>80</b>	



NOV203300U30101

## Formula List – Intermediate Tier

**Area of trapezium** =  $\frac{1}{2}(a + b)h$

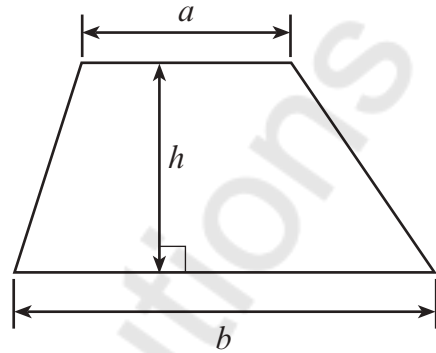

**Volume of prism** = area of cross-section  $\times$  length

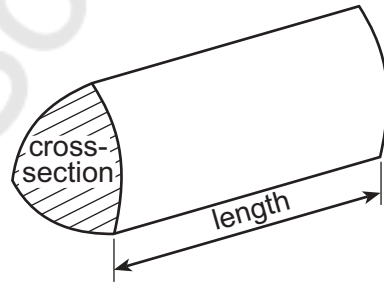

1. (a) What is the time 8 hours and 40 minutes after 11:38? [1]

.....  
.....

Time is .....

(b) What is the time difference between 7:35 a.m. and 2:15 p.m. on the same day? Give your answer in hours and minutes. [1]

.....  
.....

Time difference is ..... hours and ..... minutes.

(c) Evaluate the time difference between 7 minutes 15 seconds and 2 minutes 50 seconds. Give your answer in seconds. [2]

.....  
.....

Time difference is ..... seconds.

Examiner only

13. (a) What is the time 8 hours and 40 minutes after 11:38? [1]

11:38 a → 12:00 → 22 mins  
12:00 + 8 hrs → 8:00 pm  
40 mins - 22 mins → 18 mins →

Time is 8:18 pm → 20:18 pm

13  
14  
15  
16  
17  
18  
19  
20

(b) What is the time difference between 7:35 a.m. and 2:15 p.m. on the same day? Give your answer in hours and minutes. [1]

From 7:35 am to 12:00 → 4 hours 25 mins  
12:00 to 2:15 pm → 2 hours 15 mins

4 hrs + 2 hrs and 25 min + 15 mins

6 hours and 40 mins

Time difference is 6 hours and 40 minutes.

(c) Evaluate the time difference between 7 minutes 15 seconds and 2 minutes 50 seconds. Give your answer in seconds. [2]

6 sec → 1 min 7 min = 420 sec  
x → 7 min 7 min 15 sec → 420 sec + 15 sec = 435 sec  
x = 7 x 60 2 min 50 sec → 120 sec + 50 sec = 170 sec  
x = 420  
265

Time difference is 265 seconds.

Examiner only

7:35 → 8:35 = 1 hr  
8:35 → 9:35 = 2 hrs  
9:35 → 10:35 = 3 hrs  
10:35 → 11:35 = 4 hrs  
11:35 → 12:00 = 25 mins  
12:00 → 1:00 = 1 hr  
1:00 → 2:00 = 2 hrs  
2:00 → 2:15 = 15 mins



Mathsvault.io Solutions

2. (a) Draw the line  $x = -4$  on the grid below. [1]

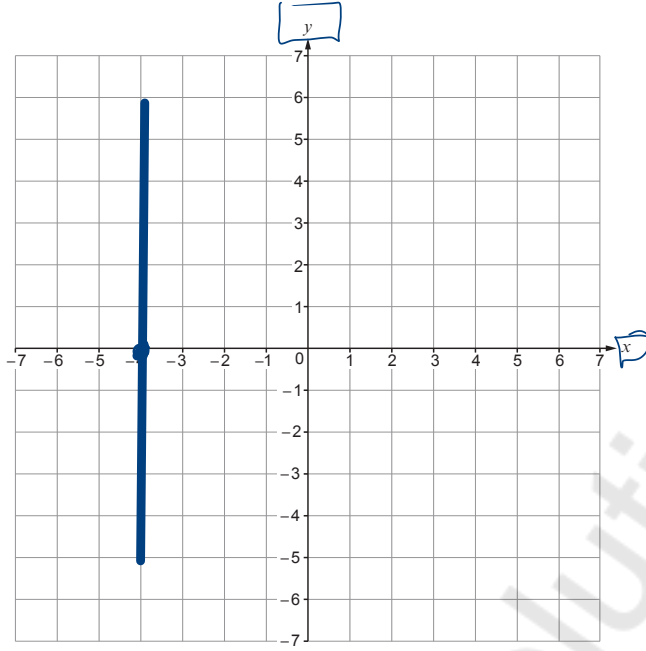

$y = -4$

$x =$  [ ]



04

© WJEC CBAC Ltd.

(3300U30-1)

Mathsvault.io Solutions

Examiner only

(b) C is a point on the grid below so that:

- $\widehat{BAC} = 90^\circ$ ,
- $AC = AB$ .

(i) Show the position of point C on the grid.

[2]

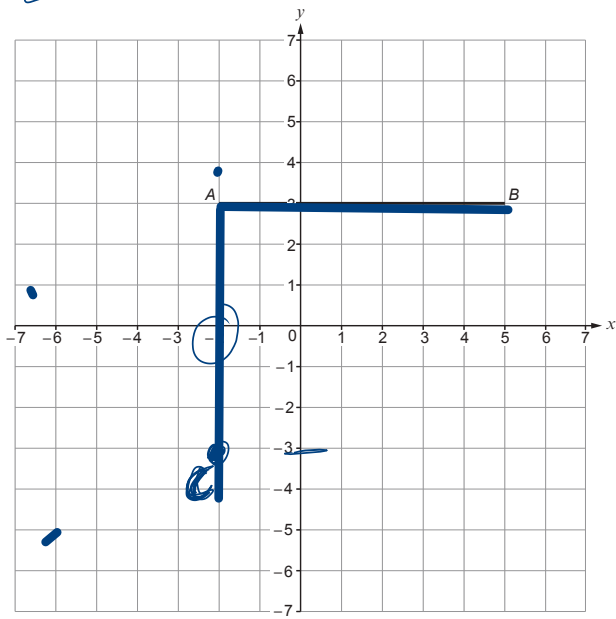

(ii) Write down the coordinates of point C.

[1]

.....



Examiner only

(b) C is a point on the grid below so that:

- $\widehat{BAC} = 90^\circ$ ,
- $AC = AB$ .

(i) Show the position of point C on the grid.

[2]

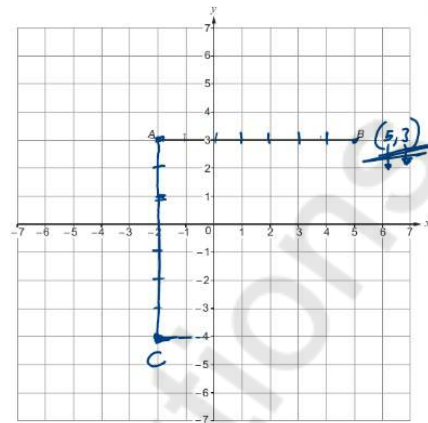

(ii) Write down the coordinates of point C.

[1]

$C = (x, y) = (-2, -4)$

$AB = AC$



$4 \times 2 = 8$

6

3. (a) Calculate each of the following.

(i)  $3^3 \times 10^2$  [2]

Shift = 2

(ii)  $0.4 \times 0.2$  [1]

$$0.4 \times 0.2 = 0.08$$

(iii)  $\frac{4}{9} + \frac{5}{18}$  [2]

(b) Write down the value of 0.0493, correct to 1 significant figure. [1]

$$0.05$$

Examiner only

14

15. Calculate each of the following

(a)  $3^3 \times 10^2$  [2]

$$\rightarrow (3 \times 3 \times 3) \times (10 \times 10)$$
$$\rightarrow 27 \times 100 = 2700$$

(b)  $0.4 \times 0.2$  [1]

$$0.4 \times 0.2 \rightarrow 4 \times 2 = 0.08$$

(c)  $\frac{4}{9} + \frac{5}{18}$  [2]

$$\frac{4}{9} + \frac{5}{18} \Rightarrow \frac{4 \times 2}{9 \times 2} + \frac{5}{18}$$
$$\Rightarrow \frac{8}{18} + \frac{5}{18} = \frac{8+5}{18} = \frac{13}{18}$$

Examiner only

11.0  
2.0 = 2



06

© WJEC CBAC Ltd.

(3300U30-1)

Mathvault.io

4. 300 students were asked if they would like to change their school's dinner menu.

The pie chart below shows how they answered.

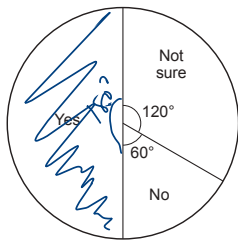

Complete the table below to show the number of students who gave each answer. [3]

Answer	Yes	No	Not sure
Number of students	150	50	100

Handwritten calculations:

$$\frac{120}{360} \times 300 = 100$$

$$\frac{60}{360} \times 300 = 50$$

$$\frac{180}{360} \times 300 = 150$$

16. 300 students were asked if they would like to change their school's dinner menu.

The pie chart below shows how they answered.

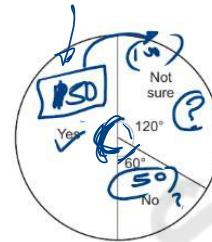

Complete the table below to show the number of students who gave each answer. [3]

Answer	Yes	No	Not sure
Number of students	150	50	100

Handwritten calculations:

$$\frac{150}{360} \times 300 = 125$$

$$\frac{50}{360} \times 300 = 41.67$$

$$\frac{100}{360} \times 300 = 83.33$$



Mathvault.io

5. (a) Solve the equation
- $4x + 7 = 10$
- . [2]

$$4x + 7 - 7 = 10 - 7$$

$$\frac{4x}{4} = \frac{3}{4}$$

$$x = \frac{3}{4}$$

- (b) Simplify
- $8d - 6e - 3d + 4e$
- . [2]

$$8d - 6e - 3d + 4e$$

$$8d - 3d - 6e + 4e = \underline{\underline{5d - 2e}}$$

6. PQ and RS are parallel.

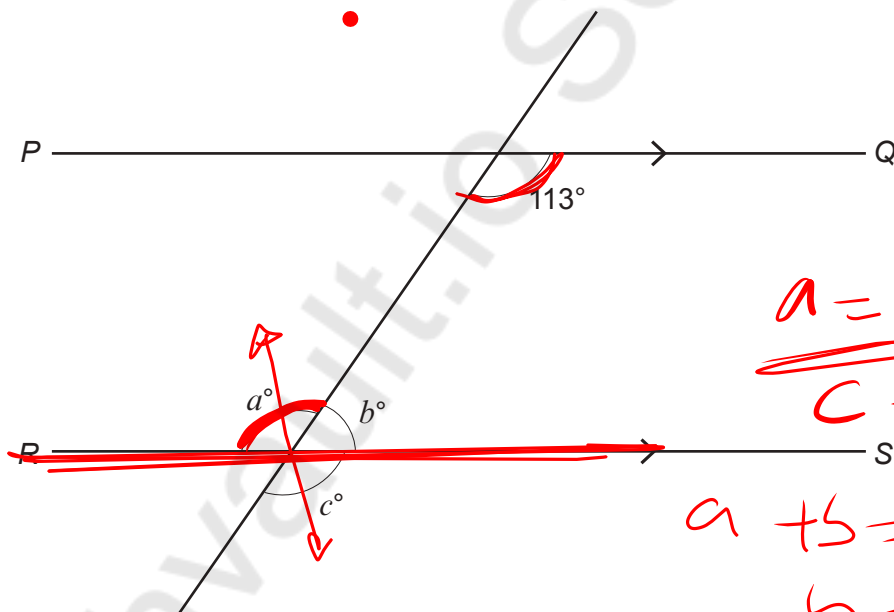

Diagram not drawn to scale

Find the values of  $a$ ,  $b$  and  $c$ .

$$a = 113^\circ$$

$$c = a^\circ = 113^\circ$$

$$a + b = 180^\circ$$

$$b = 180 - a$$

$$= 180 - 113$$

$$= 67^\circ [3]$$

$a = 113^\circ$

$b = 67^\circ$

$c = a = 113^\circ$



SSA

7. In the diagrams below,  $ABCD$  is a square. Triangles  $ABE$  and  $KLM$  are congruent.

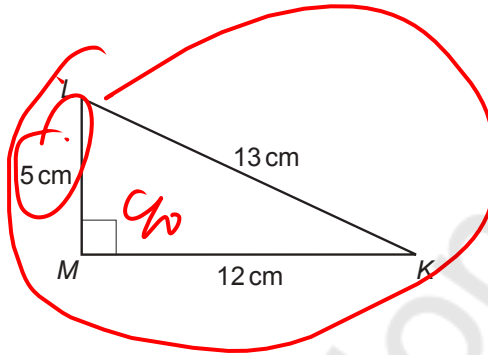
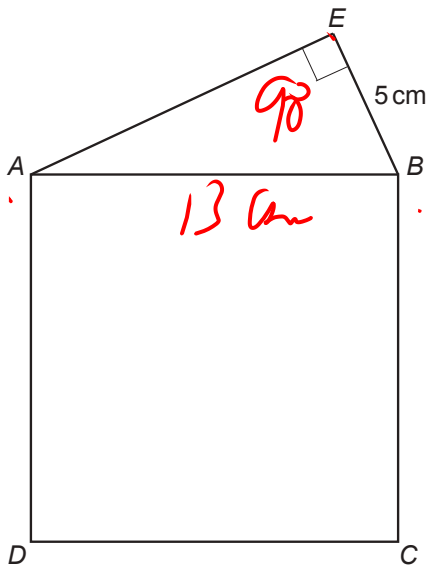

Diagrams not drawn to scale

Calculate the area of the square  $ABCD$ .

[3]

$$\begin{aligned}
 A_s &= a^2 \\
 &= 13^2 \\
 &= 169 \text{ cm}^2
 \end{aligned}$$



8. In this question, you will be assessed on the quality of your organisation, communication and accuracy in writing.

80 cards are placed in a box.  
Each card shows a picture of one of four islands near the coast of Wales:  
Bardsey Island, Ramsey Island, Skomer Island or Puffin Island.

A card is chosen at random from the box.  
The table below gives some of the probabilities that the chosen card shows a picture of a particular island.

Island	Bardsey Island (Ynys Enlli)	Ramsey Island (Ynys Dewi)	Skomer Island (Ynys Sgomer)	Puffin Island (Ynys Seiriol)
Probability	0.4	0.15	0.25	$x$

How many of the 80 cards show a picture of Puffin Island?  
You must show all your working.

[4 + 2 OCW]

$$\sum P(E) = 1$$

$$0.4 + 0.15 + 0.25 + x = 1$$

$$0.8 + x \neq 1$$

$$x = 1 - 0.8$$

$$x = 0.2$$

$$0.2 \times 80 = 16 \text{ Cards}$$

$$\begin{array}{r} 0.4 \\ 0.15 \\ 0.25 \\ \hline 0.80 \\ \hline 0.4 \times 80 \\ 80 \\ \times 2 \\ \hline 160 \\ \hline = 16.0 \end{array}$$



9. (a) Two sides of a parallelogram ABCD are drawn accurately below. Using only a ruler and a pair of compasses, complete an accurate drawing of the parallelogram. You must show all your construction arcs. [2]

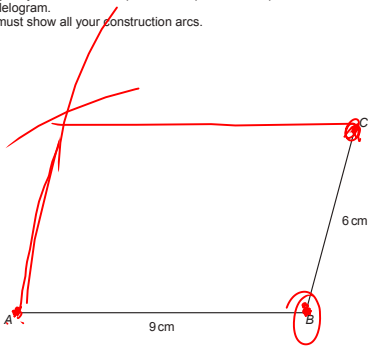

- (b) The line XY below forms part of a scale drawing of a garden. The scale drawing has a scale of 1:200. What is the actual distance between point X and point Y in the garden? Give your answer in metres. [3]



.....  
 .....  
 .....  
 Actual distance between point X and point Y = ..... metres

19. (a) Two sides of a parallelogram ABCD are drawn accurately below. Using only a ruler and a pair of compasses, complete an accurate drawing of the parallelogram. You must show all your construction arcs. [2]

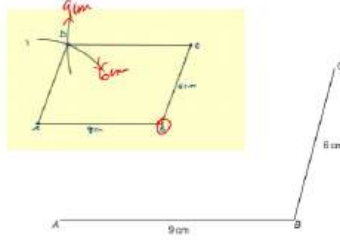

- (b) The line XY below forms part of a scale drawing of a garden. The scale drawing has a scale of 1:200. What is the actual distance between point X and point Y in the garden? Give your answer in metres. [3]



Using a scale 1:200  
 Real-life distance = Measured length  $\times$  200  
 $= 7.6 \times 200 = 1520 \text{ cm}$   
 Actual distance between point X and point Y = 15.2 metres



Handwritten calculations for question 19(b):

$$\begin{array}{r} 200 \times 7.6 \\ 76 \\ \hline 1200 \\ 1400 \\ \hline 15200 \end{array}$$

20

$$\begin{array}{r} 15200 \\ 100 \\ \hline 152 \end{array}$$

15.2

$$\begin{array}{r} 15200 \\ 100 \\ \hline 152 \end{array}$$

15.2

$$\begin{array}{r} 15200 \\ 100 \\ \hline 152 \end{array}$$

15.2



Mathsvault.io Solution

10. You are given that  $543 \times 17 = 9231$ .

- (a) What is the value of  $543 \times 1.7$ ?  
Circle the correct answer.

0.9231    9.231    92.31    923.1    9231

[1]

- (b) What is the value of  $\frac{9231}{54.3}$ ?  
Circle the correct answer.

0.17    1.7    17    170    1700

[1]

- (c) What is the value of  $\frac{9231}{543 \times 1.7}$ ?  
Circle the correct answer.

0.1    1    10    100    1000

[1]



20. You are given that  $543 \times 17 = 9231$ .

- (a) What is the value of  $543 \times 1.7$ ?  
Circle the correct answer.

0.9231    9.231    92.31    923.1    9231

$$9231 \div 10 = 9.231$$

- (b) What is the value of  $\frac{9231}{54.3}$ ?  
Circle the correct answer.

0.17    1.7    17    170    1700

$$= 170$$

- (c) What is the value of  $\frac{9231}{543 \times 1.7}$ ?  
Circle the correct answer.

0.1    1    10    100    1000

$$= \frac{9231}{9231} = 1$$

$$= 10$$

END OF PAPER



9

$$\frac{9231}{54.3} = \frac{9231}{543 \div 10} = \frac{9231 \times 10}{543} = 170$$

$$\Rightarrow 170$$

$$\frac{9231}{54.3} = \frac{9231 \div 10}{54.3 \div 10} = \frac{923.1}{5.43} = 170$$

$$\frac{9231}{54.3} = 170$$

$$\frac{9231}{54.3} = 170$$

$$\frac{9231}{54.3} = 170$$

$$\frac{9231}{54.3} = 170$$

$$\frac{9231}{54.3} = 170$$

$$\frac{9231}{54.3} = 170$$

Mathvault.io Solutions

11. (a) Write an expression for the  $n$ th term of the following sequence. [2]

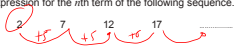

$n$ th term =  $5n - 3$

(b) The first four diagrams in a sequence are shown below.



Complete the following subtraction.

Number of circles in Diagram 17 - Number of circles in Diagram 16 = 17

(c) The first three diagrams in another sequence are shown below.



Give an expression, in terms of  $n$ , for the number of dots (•) in Diagram  $n$ . You must simplify your expression. [2]



$$T_n = a + (n-1)d$$

$$= 2 + (n-1)5$$

$$= 2 + 5n - 5$$

$$= 5n - 3$$
  

$$(17 + 16 + 15 + \dots + 1) - (16 + 15 + \dots + 1)$$

$$= 17$$

1. (a) Write an expression for the  $n$ th term of the following sequence. [2]

$$a \Rightarrow \text{first term} = 2; \text{Common difference} = 5 \Rightarrow d$$

$$T_n = a + (n-1)d = 2 + (n-1)5 = 2 + 5n - 5 = 5n - 3$$

(b) The first four diagrams in a sequence are shown below.

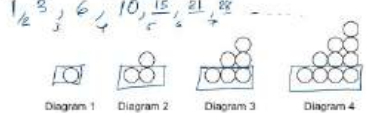

Complete the following subtraction:

Number of circles in Diagram 17 - Number of circles in Diagram 16 = 17

(c) The first three diagrams in another sequence are shown below.



Give an expression, in terms of  $n$ , for the number of dots (•) in Diagram  $n$ . You must simplify your expression. [2]

$$\Rightarrow 4, 6, 8; a=4, d=2$$

$$T_n = a + (n-1)d = 4 + (n-1)2 = 4 + 2n - 2$$

$$T_n = 2n + 2 = 2n + 2 \text{ or } 2(n+1)$$



Mathvault.io

12. (a) On each Venn diagram, shade the region that represents the given set.

(i)  $A \cup B$

[1]

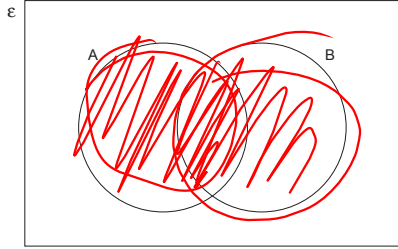

(ii)  $A' \cap B$

[1]

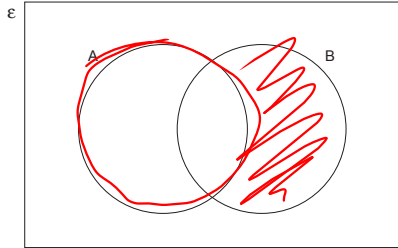

2. (a) On each Venn diagram, shade the region that represents the given set.

(i)  $A \cup B$

[1]

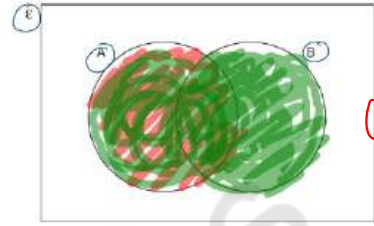

(ii)  $A' \cap B$

[1]

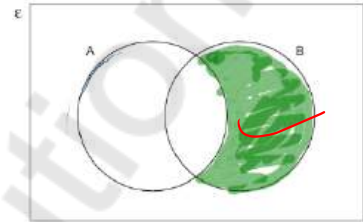

Mathvault.io Solutions

(b) In the Venn diagram below:

- Set A = multiples of 3.
- Set B = multiples of 5.
- Set C = multiples of 6.

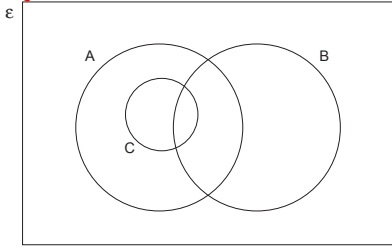

Explain why the circle representing Set C is drawn inside the circle drawn to represent Set A. [1]

13. A sum of money is shared in the ratio 3 : 4 : 7. The smallest share is £210. What is the total amount of money shared? You must show all your working. [4]

$$\begin{aligned} \Rightarrow 3 + 4 + 7 &= 14 \\ \Rightarrow \frac{£210}{3} &= 70 \\ &= 70 \times 14 = £980 \end{aligned}$$

36912151821

(b) In the Venn diagram below:

- Set A = multiples of 3. = 3, 6, 9, 12, 15, 18, 21, ...
- Set B = multiples of 5. = 5, 10, 15, 20, 25, 30, ...
- Set C = multiples of 6. = 6, 12, 18, 24, 30, 36, ...

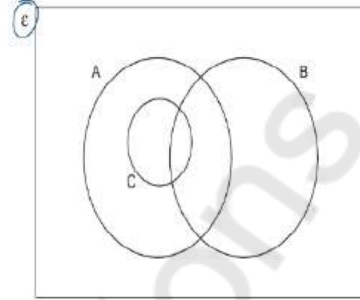

Explain why the circle representing Set C is drawn inside the circle drawn to represent Set A. [1]

⇒ The reason is because 3 is a factor of 6.

?



Mathsvault.io

$$y = x^2 - 4x - 3$$

$$y = (-2)^2 - 4(-2) - 3$$

$$= 4 + 8 - 3$$

$$= 12 - 3$$

$$= 9$$

$x = -2$

14. The table below shows some of the values of  $y = x^2 - 4x - 3$  for values of  $x$  from -2 to 5.

x	-2	-1	0	1	2	3	4	5
$y = x^2 - 4x - 3$	9	2	-3	-6	-6	-3	2	

(a) Complete the table by finding the value of  $y$  for  $x = -2$  and the value of  $y$  for  $x = 2$ . [2]

(b) On the graph paper opposite, draw the graph of  $y = x^2 - 4x - 3$  for values of  $x$  from -2 to 5. [2]

(c) Draw the line  $y = 1$  on the graph paper. Write down the values of  $x$  where the line  $y = 1$  cuts the curve  $y = x^2 - 4x - 3$ . [2]

Values of  $x$  are \_\_\_\_\_ and \_\_\_\_\_

$y = 1$   
 $y = 1$

14. The table below shows some of the values of  $y = x^2 - 4x - 3$  for values of  $x$  from -2 to 5.

x	-2	-1	0	1	2	3	4	5
$y = x^2 - 4x - 3$	9	2	-3	-6	-6	-3	2	

(a) Complete the table by finding the value of  $y$  for  $x = -2$  and the value of  $y$  for  $x = 2$ . [2]

$y = x^2 - 4x - 3$   
Let  $x = -2$   
 $y = (-2)^2 - 4(-2) - 3$   
 $y = 4 + 8 - 3$   
 $y = 12 - 3$   
 $y = 9$

Let  $x = 2$   
 $y = (2)^2 - 4(2) - 3$   
 $y = 4 - 8 - 3$   
 $y = -4 - 3$   
 $y = -7$

(b) On the graph paper opposite, draw the graph of  $y = x^2 - 4x - 3$  for values of  $x$  from -2 to 5. [2]

(c) Draw the line  $y = 1$  on the graph paper. Write down the values of  $x$  where the line  $y = 1$  cuts the curve  $y = x^2 - 4x - 3$ . [2]

Values of  $x$  are  $-0.8$  and  $4.8$

14. The table below shows some of the values of  $y = x^2 - 4x - 3$  for values of  $x$  from -2 to 5.

x	-2	-1	0	1	2	3	4	5
$y = x^2 - 4x - 3$	9	2	-3	-6	-6	-3	2	

(a) Complete the table by finding the value of  $y$  for  $x = -2$  and the value of  $y$  for  $x = 2$ . [2]

(b) On the graph paper opposite, draw the graph of  $y = x^2 - 4x - 3$  for values of  $x$  from -2 to 5. [2]

(c) Draw the line  $y = 1$  on the graph paper. Write down the values of  $x$  where the line  $y = 1$  cuts the curve  $y = x^2 - 4x - 3$ . [2]

Values of  $x$  are  $-0.8$  and  $4.8$

$y = 1$

$x = -0.8 \rightarrow -0.8$   
 $x = 4.8 \rightarrow 4.8$

Mathvault.io Solutions

Examiner only

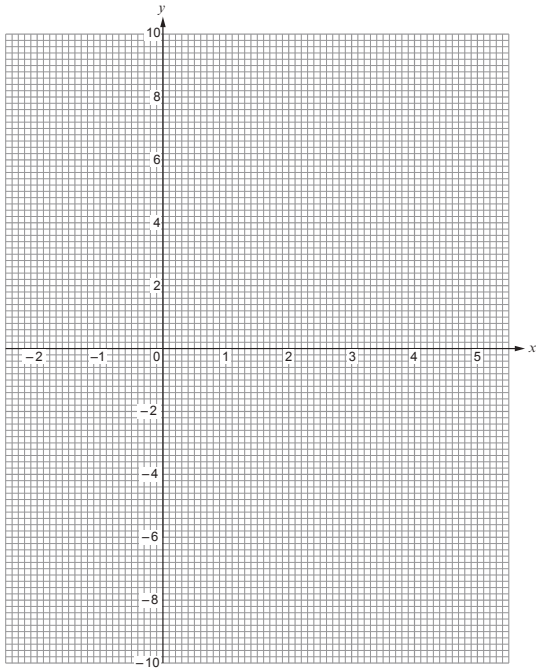

Turn over.

Examiner only

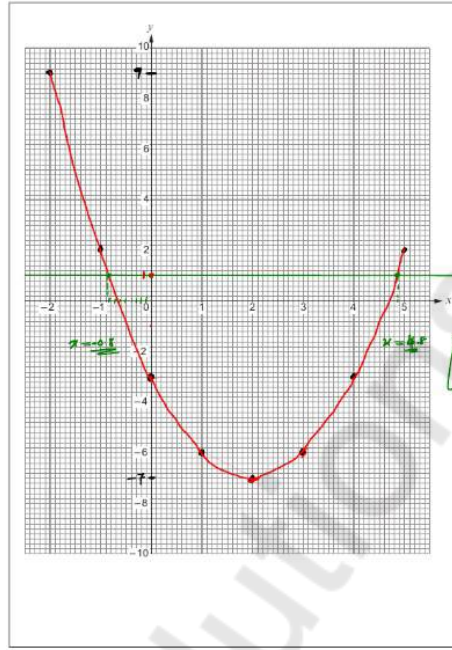

x	①	-1	0	1	②	3	4	③
$y = x^2 - 4x - 1$	9	2	-1	-4	-3	-4	-3	2

$g = 1$

$x = -0.8 \rightarrow -0.55$   
 $x = 4.8 \rightarrow 4.85$



Turn over.

Mathvault.io Solutions

15. Find four **different** positive whole numbers so that:

- their mean is 8.
- their range is 8.
- their median is 8.

Write your four numbers in the boxes below. [3]

.....

.....

.....

.....

.....

.....

.....

.....

The four numbers are

4 ~~5~~ ~~6~~ 12



5. Find four **different** positive whole numbers so that:

- their mean is 8,
- their range is 8,
- their median is 8.

Write your four numbers in the boxes below.

Range:  $d - a = 8$  ;

$\frac{b+c}{2} = 8$  ; med

Mean =  $\frac{a+b+c+d}{4} = 8$

$b+c = 8 \times 2 = 16$

$a+16+d = 8 \times 4 = 32$

Rec:  $d - a = 8$

$a+d+16 = 32$

$d - a = 8$

$a+d = 32 - 16 = 16$

$d = 8 + a = 12$  ✓

$a+d = 16$

$a=4, d=12$

$a+8+a = 16$

$2a+8 = 16$

$\frac{2a}{2} = \frac{16-8}{2} \Rightarrow a = 4$

The four numbers are

4 12

Mathvault.io

16. (a) Factorise  $x^2 - 7x + 12$ , and hence solve  $x^2 - 7x + 12 = 0$ . [3]

Examiner only

- (b) Expand and simplify  $(5x - 2)^2$ . [2]

10

6. (a) Factorise  $x^2 - 7x + 12$ , and hence solve  $x^2 - 7x + 12 = 0$ . [3]

$$\begin{array}{l}
 x^2 - 7x + 12 \\
 \underline{x^2 - 4x - 3x + 12} \\
 x(x-4) - 3(x-4) \\
 (x-3)(x-4)
 \end{array}
 \quad
 \begin{array}{l}
 (x-3)(x-4) = 0 \\
 x-3=0 \text{ or } x-4=0 \\
 x=0+3 \text{ or } x=0+4 \\
 x=3 \text{ or } 4
 \end{array}$$

Examiner only



- (b) Expand and simplify  $(5x - 2)^2$ . [2]

$$\begin{aligned}
 (5x-2)^2 &= (5x-2)(5x-2) \\
 &= 5x(5x-2) - 2(5x-2) \\
 &= 25x^2 - 10x - 10x + 4 \\
 &= 25x^2 - 20x + 4
 \end{aligned}$$



Mathsvault.io Solutions

17. Alice works for an engineering company.

A working day is chosen at random.

From keeping a record over the last year, Alice knows that, for this working day,

- the probability that she travels to work by car is 0.7,
- the probability that she arrives at work before 8:00 a.m. is 0.4,
- her time of arrival is independent of how she travels to work.

(a) Using the above information, draw and fully label a complete tree diagram. You must include all probabilities. [4]

(b) What is the probability that, on the randomly-chosen working day, Alice travels to work by car and arrives before 8:00 a.m.? [2]

$$\begin{aligned}
 P(\text{Car and Arrive}) &\Rightarrow P(C) \times P(A) \\
 &\Rightarrow 0.7 \times 0.4 \\
 &= 0.28
 \end{aligned}$$



7. Alice works for an engineering company.

A working day is chosen at random.

From keeping a record over the last year, Alice knows that, for this working day,

- the probability that she travels to work by car is 0.7,
- the probability that she arrives at work before 8:00 a.m. is 0.4,
- her time of arrival is independent of how she travels to work.

(a) Using the above information, draw and fully label a complete tree diagram. You must include all probabilities. [4]

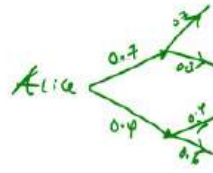

(b) What is the probability that, on the randomly-chosen working day, Alice travels to work by car and arrives before 8:00 a.m.? [2]



22

19. (a) Which one of the following equations represents a straight line that is parallel to the line  $2y = 5x - 4$ ?  
Circle your answer. [1]

$y = 2.5x + 3$     $y = 5x - 2$     $y = 0.4x - 4$     $y = -0.4x - 2$     $2y = -5x + 4$

(b) Which one of the following equations represents a straight line that intersects the line  $y = 7x - 3$  on the y-axis?  
Circle your answer. [1]

$y = 7x - 3$     $y = 3 - 7x$     $y = 3x + 5$     $y = 0$     $y = 3x - 5$

(c) Which one of the five straight lines shown above could represent the equation  $y = -2x + 3$ ?  
Circle your answer. [1]

Line A   Line B   Line C   Line D   Line E

END OF PAPER

$2y = 5x - 4$   
 $\frac{2y}{2} = \frac{5x - 4}{2}$   
 $y = 2.5x - 2$   
 $y = mx + c$



22

© WJEC CBAC Ltd.

(330020-1)

13

9. (a) Which one of the following equations represents a straight line that is parallel to the line  $2y = 5x - 4$ ?  
Circle your answer. [1]

$y = 2.5x + 3$     $y = 5x - 2$     $y = 0.4x - 4$     $y = -0.4x - 2$     $2y = -5x + 4$

$y = mx + c$   
 $\frac{2y}{2} = \frac{5x - 4}{2}$   
 $y = 2.5x - 2$   
 Slope = 2.5

(b) Which one of the following equations represents a straight line that intersects the line  $y = 7x - 3$  on the y-axis?  
Circle your answer. [1]

$y = 7x - 3$     $y = 3 - 7x$     $y = 3x + 5$     $y = 0$     $y = 3x - 5$

$y = mx + c$   
 $y = 7x - 3$   
 Intersect  $\Rightarrow -3$     $y = 3x - 5$

(c) Which one of the five straight lines shown above could represent the equation  $y = -2x + 3$ ?  
Circle your answer. [1]

Line A   Line B   Line C   Line D   Line E

END OF PAPER

Line A & Line D  
 $c = 3$



13

© WJEC CBAC Ltd.

(330020-1)

Turn over.

Mathsvault.io Solutions

Question number	Additional page, if required. Write the question number(s) in the left-hand margin.
	<p>Mathsvault.io Solutions</p>

Examiner only



**BLANK PAGE**

**PLEASE DO NOT WRITE  
ON THIS PAGE**

Mathvaudio Solutions

