

Surname	Centre Number	Candidate Number
First name(s)		0



GCSE

3300U30-1



TUESDAY, 24 MAY 2022 – MORNING

**MATHEMATICS
UNIT 1: NON-CALCULATOR
INTERMEDIATE TIER**

1 hour 35 minutes

ADDITIONAL MATERIALS

The use of a calculator is not permitted in this examination.
A ruler, a protractor and a pair of compasses may be required.

INSTRUCTIONS TO CANDIDATES

Use black ink or black ball-point pen. Do not use gel pen or correction fluid.

You may use a pencil for graphs and diagrams only.

Write your name, centre number and candidate number in the spaces at the top of this page.

Answer **all** the questions in the spaces provided.

If you run out of space, use the additional page at the back of the booklet. Question numbers must be given for all work written on the additional page.

Take π as 3.14.

INFORMATION FOR CANDIDATES

You should give details of your method of solution when appropriate.

Unless stated, diagrams are not drawn to scale.

Scale drawing solutions will not be acceptable where you are asked to calculate.

The number of marks is given in brackets at the end of each question or part-question.

In question **8**, the assessment will take into account the quality of your linguistic and mathematical organisation, communication and accuracy in writing.

For Examiner's use only		
Question	Maximum Mark	Mark Awarded
1.	4	
2.	3	
3.	4	
4.	3	
5.	4	
6.	3	
7.	5	
8.	6	
9.	3	
10.	4	
11.	5	
12.	6	
13.	2	
14.	6	
15.	4	
16.	4	
17.	2	
18.	2	
Total	70	



JUN223300U30101

Formula List – Intermediate Tier

Area of trapezium = $\frac{1}{2}(a + b)h$

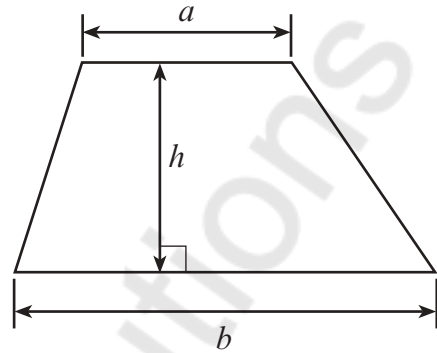

Volume of prism = area of cross-section \times length

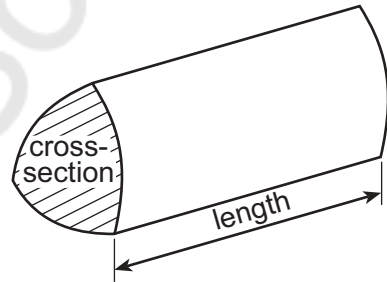

1. Calculate each of the following.

(a) $3^2 \times 2^3$

[2]

$$3 \times 3 \times 2 \times 2 \times 2$$

$$= 9 \times 8 = 72$$

(b) $-124 \div 4$

[1]

$$\begin{array}{r} 31 \\ -124 \\ \hline 4 \\ = -31 \end{array}$$

(c) 15% of 280

[1]

$$\frac{15}{100} \times \frac{280}{1} = 1.5 \times 28$$

$$\Rightarrow 42$$

2. Write 0.3, $\frac{8}{25}$ and 31% in ascending order.

You must show all your working.

$$\frac{8}{25} = 0.32 \quad \& \$ 31\% = 0.31 \quad [3]$$

$$0.3, 0.31, 0.32$$

$$0.3, 31\%, \frac{8}{25}$$

$$0.3$$

Smallest value

$$31\%$$

$$\frac{8}{25}$$

Greatest value

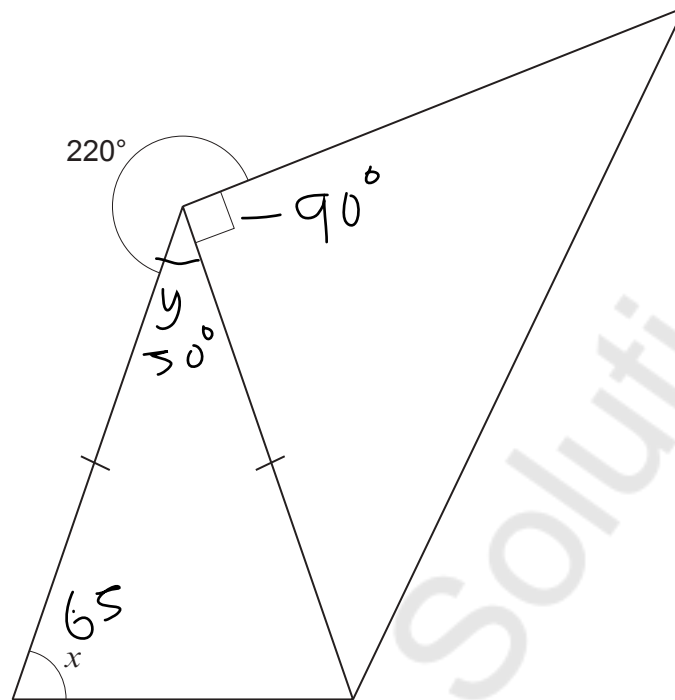

3.

Diagram not
drawn to scale

Calculate the size of angle x .
You must show all your working.

[4]

$$y = 360 - 220 - 90$$

$$= 50^\circ$$

$$x = \frac{180 - 50}{2} = 65^\circ$$

$$x = 65^\circ$$



4. Imran is 9 years older than Glyn.
Glyn is twice as old as Sheila.
The sum of the three ages is 49 years.
How old are Imran, Glyn and Sheila?

[3]

$$\text{Sheila's age} = x : \text{Glyn} = 2x$$

$$\text{Imran} = 2x + 9$$

$$x + 2x + 2x + 9 = 49$$

$$5x + 9 = 49$$

$$5x = 40$$

$$x = 40 \div 5 = 8$$

Imran = 25 years old. Glyn = 16 years old. Sheila = 8 years old.

5. (a) Find a whole number value of n , so that $7n - 9$ is a multiple of 4.
You must show all your working.

[2]

$$n = 3 : 7(3) - 9 \Rightarrow 21 - 9$$

$$= 12 \quad (12 \div 4) = 3$$

When $n = 3$, $7n - 9$ is a multiple of 4.

- (b) Find a whole number value of n , so that $3n - 5$ is a prime number.
You must show all your working.

[2]

$$n = 4 : 3(4) - 5 \Rightarrow 12 - 5$$

$$= 7$$

When $n = 4$, $3n - 5$ is a prime number.



6. (a) A bag contains red balls, green balls and yellow balls.
The number of green balls is equal to the number of yellow balls.

Mali picks one ball from the bag at random.
The probability that she will pick a red ball is 0.3.

Find the probability that Mali will pick a yellow ball.

[2]

$$1 - 0.3 = 0.7$$

$$P(y+g) = 0.7$$

$$P(y) = 0.7 \div 2 = 0.35$$

- (b) A different bag contains 10 balls.
Some of the balls in the bag are blue.
All the other balls are white.
Morgan picks a ball from the bag at random.
He says,

The probability that I will pick a blue ball from
the bag is 0.25.

Explain why Morgan cannot be correct.

[1]

$$\Rightarrow 0.1, 0.2, 0.3, 0.4$$

10 is not divisible by 4



7. Solve each of the following equations.

(a) $4y - 3 = 15$

[2]

$$4y = 15 - 3$$

$$4y = 12$$

$$y = 12 \div 4 = 4.5 //$$

(b) $8x - 38 = 17 - 3x$

[3]

$$8x + 3x = 17 + 38$$

$$11x = 55$$

$$x = \frac{55}{11} = 5 //$$



8. In this question, you will be assessed on the quality of your organisation, communication and accuracy in writing.

A rectangle and a trapezium are shown below.

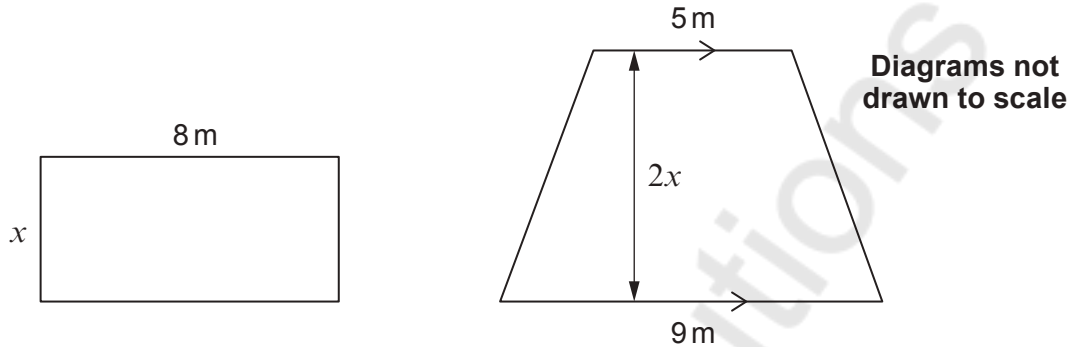

The area of the rectangle = 48 m^2 .

The width of the rectangle is represented by x .

The height of the trapezium is twice the width of the rectangle.

Calculate the area of the trapezium.

You must show all your working.

[4 + 2 OCW]

$$48 = 8x \Rightarrow x = \frac{48}{8} = 6$$

$$h = 6 \times 2 = 12$$

$$\begin{aligned} A &= \frac{1}{2} (a+b) h \\ &= \frac{1}{2} (5+9) 12 \\ &= 84 \text{ m}^2 \end{aligned}$$



9. Write down four whole numbers so that:
- they are all between 1 and 15 inclusive
 - they have a mode of 7
 - they have a median value of 8.5
 - their mean is 9.

Write your numbers in the boxes below.

[3]

Mode = 7

Highest occurring number = 7

7

7

10

12



10.

Diagram not
drawn to scale

ABC is a straight road, where the ratio $AB : BC = 3 : 4$.
 $AC = 56$ km.

Calculate the length of BC .

Give your answer in **miles**.

You must show all your working.

[4]

$$\text{Total} = 4 + 3 = 7$$

$$BC = \frac{4}{7} \times 56 = 32 \text{ km}$$

32 km to miles

$$\Rightarrow 19.88 \text{ miles} \approx 20 \text{ miles}$$

Length of $BC = 20$ miles



BLANK PAGE

**PLEASE DO NOT WRITE
ON THIS PAGE**



11. The table below shows some of the values of $y = x^2 + x - 4$ for values of x from -3 to 3 .

x	-3	-2	-1	0	1	2	3
$y = x^2 + x - 4$	2	-2	-4	-4	-2	2	8

(a) Complete the table by finding the values of y for $x = -1$ and for $x = 1$.

[2]

$$x = -1 : y = (-1)^2 + (-1) - 4 \Rightarrow -4$$

$$x = 1 : y = (1)^2 + 1 - 4 \Rightarrow -2$$

(b) On the graph paper opposite, draw the graph of $y = x^2 + x - 4$ for values of x from -3 to 3 .

[2]

(c) Use your graph to solve the equation $x^2 + x - 4 = 0$.
Give your answers correct to 1 decimal place.

[1]

$$y = mx + c$$

$$x = -2.6 \quad \text{or} \quad x = 1.6$$



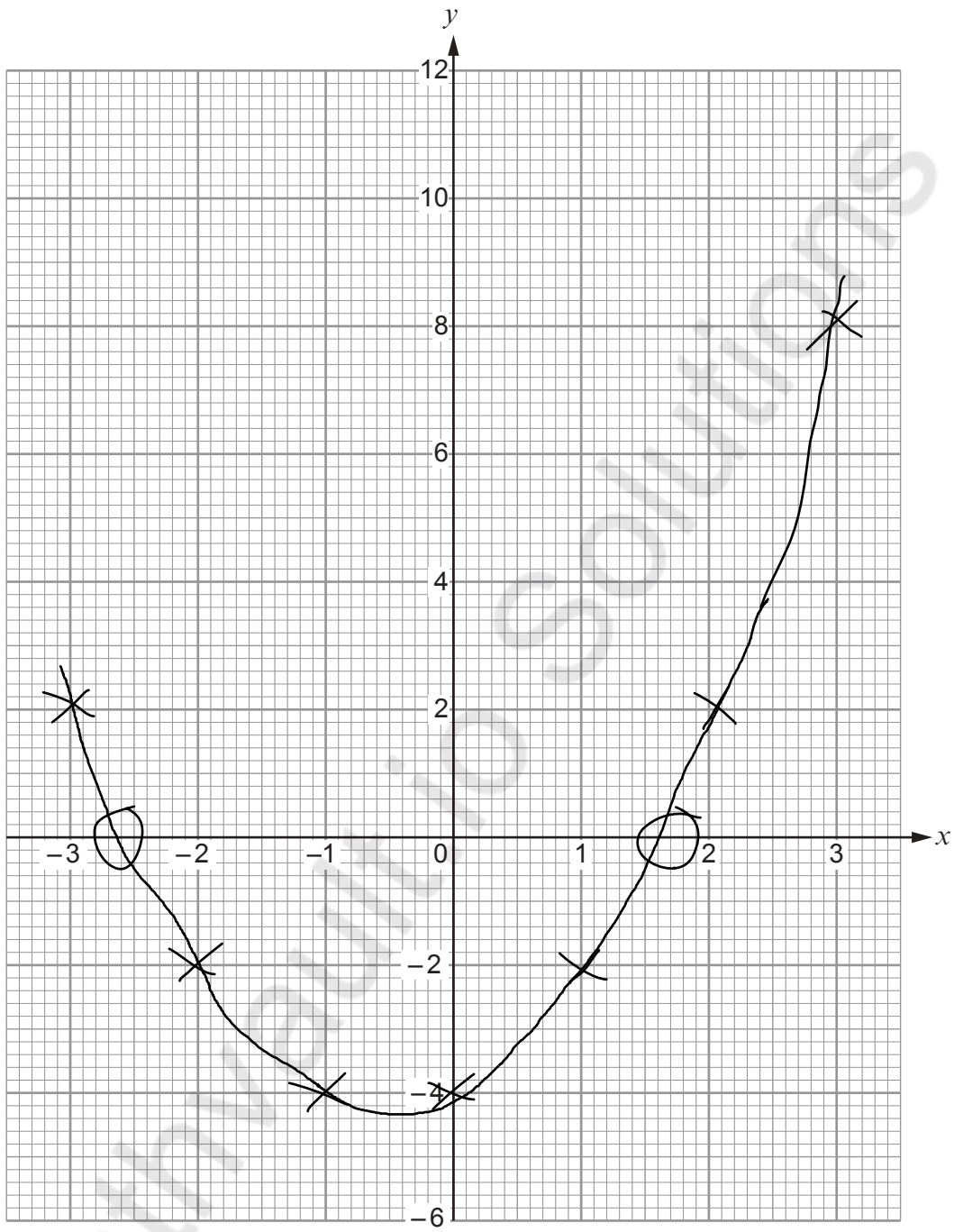

12. The children in year 5 and year 6 in a primary school took part in a survey. The children were asked, "How many pets do you have?" The results are shown in the pie chart and bar chart below. No child in either year had more than 5 pets.

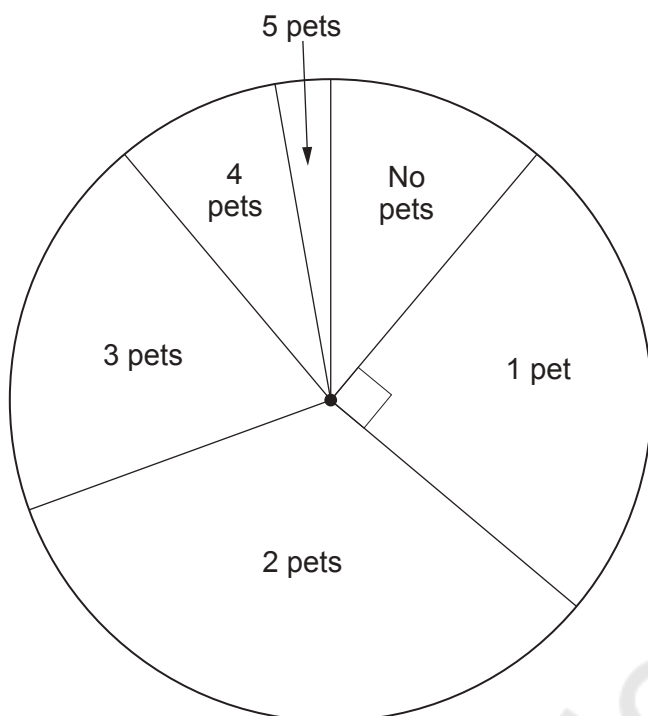

Year 5

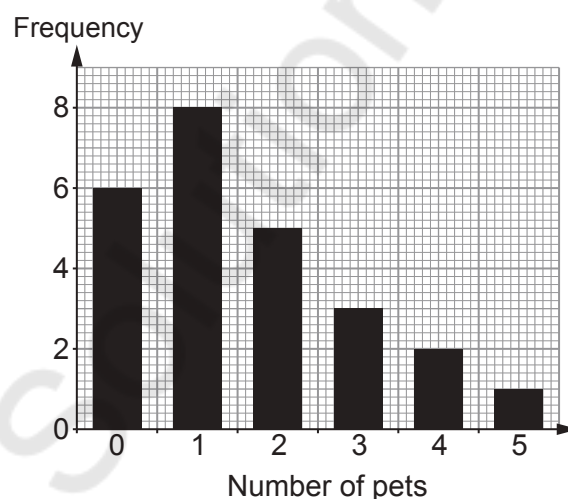

Year 6

There are 36 children in year 5.

One child is chosen at random from all the children in year 5 and year 6.

What is the probability that this child has no more than 1 pet?

[6]

$$\text{No pet} = 40^{\circ} \pm 2^{\circ}$$

$$\begin{aligned} (\text{Yr 5: 0 pet}) &= \frac{40^{\circ} \pm 2^{\circ}}{360} \times 36 \\ &= 4 \end{aligned}$$

$$\text{Yr 5: 1 pet} = 9$$

$$\begin{aligned} \text{Probability of not more than 1 pet} \\ &= 27/61 // \end{aligned}$$



13. Write down an expression for the n th term of the following sequence. [2]

15, 9, 3, -3, ...

$$\text{Difference} = -6$$

$$\begin{aligned} \text{nth term} &= 15 + (n-1)(-6) \\ &= 21 - 6n \end{aligned}$$



14. A and B are independent events.
The probability of event A occurring is 0.6.
The probability of event A **and** event B occurring is 0.48.

(a) Complete the tree diagram.

[4]

$$P(B) = \frac{0.48}{0.6} = 0.8$$

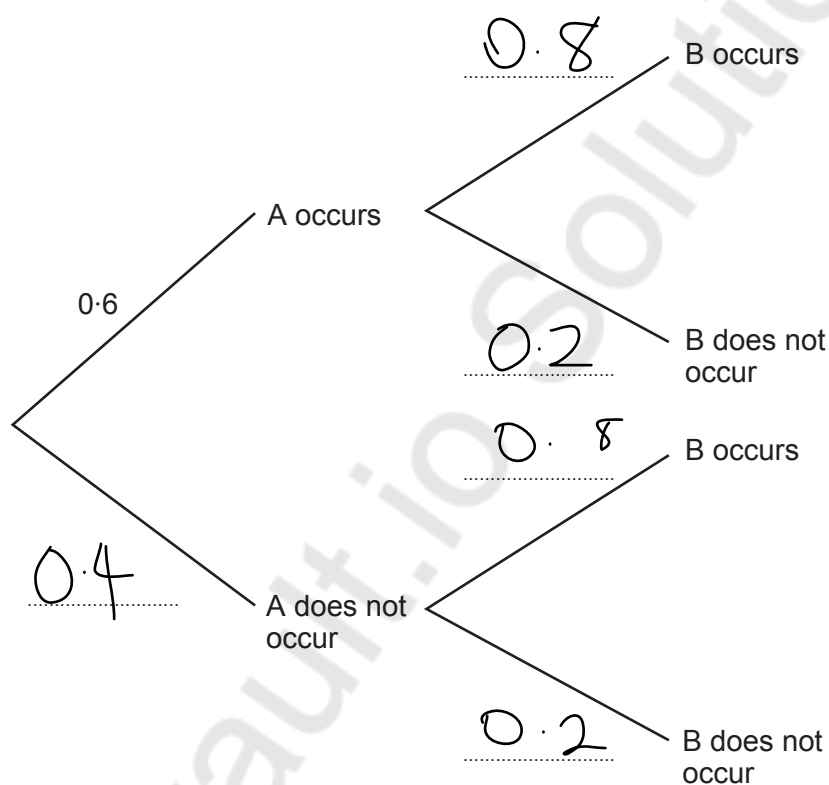

(b) Calculate the probability of neither event A nor event B occurring.

[2]

$$P(\text{not } A) = 0.4$$

$$P(\text{not } B) = 0.2$$

$$P(\text{neither}) = 0.4 \times 0.2 = 0.08 //$$



15. In the diagram:

- AB and ED are parallel
- triangles ABC and DEC are similar.

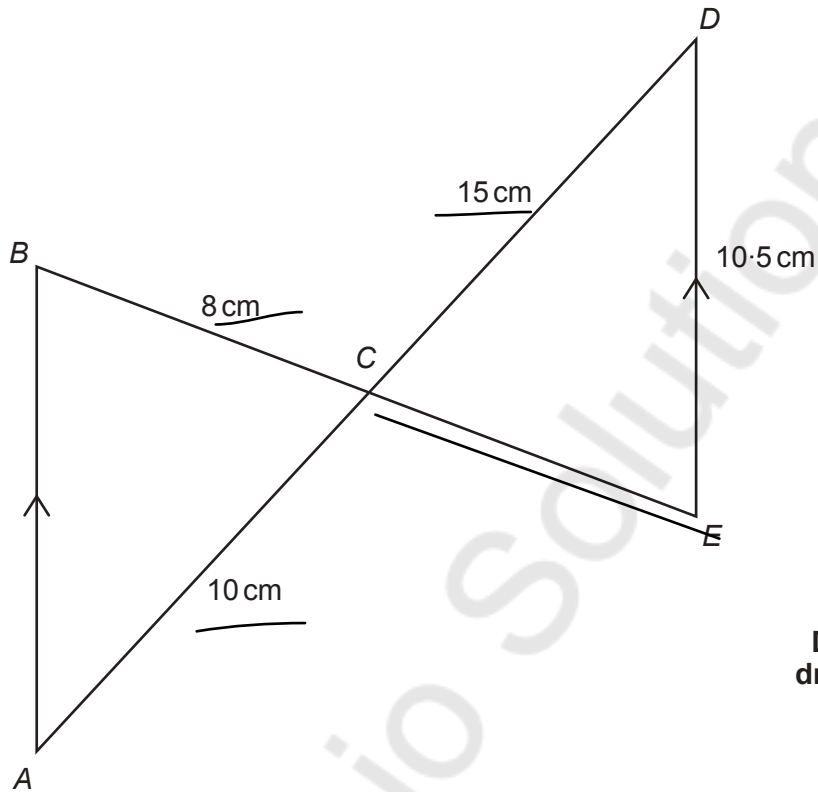

Diagram not
drawn to scale

(a) Calculate the length of CE .

[2]

~~$$CE = 10.5 \times \frac{10}{15} = 7 \text{ cm}$$~~

$$CE = 8 \times \frac{15}{10} = 12 \text{ cm}$$

(b) Calculate the length of AB .

[2]

$$AB = 10.5 \times \frac{10}{15} = 7 \text{ cm} //$$



16. Solve the following simultaneous equations using an algebraic (not graphical) method. You must show all your working. [4]

$$2x + 3y = 29 \quad \text{---} \quad \text{i}$$

$$5x - 4y = -8 \quad \text{---} \quad \text{ii}$$

$$\text{(i)} \times 4 \quad \text{(ii)} \times 3$$

$$\begin{array}{r} 8x + 12y = 116 \\ + \quad 15x - 12y = -24 \\ \hline 23x \qquad \qquad \qquad 92 \end{array}$$

$$x = 92 \div 23 = 4$$

$$y = 7$$



17. Circle the correct answer for each of the following statements.

(a) 7.2m^3 is equal to

[1]

 720cm^3 72000cm^3 $7.2 \times 10^5\text{cm}^3$ $7.2 \times 10^3\text{cm}^3$ $7.2 \times 10^6\text{cm}^3$

(b) $36^{\frac{1}{2}}$ is equal to

[1]

18

6

 $\frac{1}{18}$ $\frac{1}{6}$ $\frac{1}{36}$

18. Find the value of $\frac{30000}{1.5 \times 10^5}$.

Write your answer as a decimal.

[2]

$$\frac{\cancel{30,000}}{\cancel{150,000}} = \frac{3}{15} = 0.2 //$$

END OF PAPER



Question number	Additional page, if required. Write the question number(s) in the left-hand margin.
	<p>Mathsvault.io Solutions</p>

Examiner only

