

Surname	Centre Number	Candidate Number
First name(s)		0



GCSE

3300U10-1



MONDAY, 13 NOVEMBER 2023 – MORNING

**MATHEMATICS
UNIT 1: NON-CALCULATOR
FOUNDATION TIER**

1 hour 30 minutes

ADDITIONAL MATERIALS

The use of a calculator is not permitted in this examination.
A ruler, a protractor and a pair of compasses may be required.

INSTRUCTIONS TO CANDIDATES

Use black ink or black ball-point pen. Do not use gel pen or correction fluid.

You may use a pencil for graphs and diagrams only.

Write your name, centre number and candidate number in the spaces at the top of this page.

Answer **all** questions.

Write your answers in the spaces provided in this booklet. If you run out of space, use the additional page(s) at the back of the booklet, taking care to number the question(s) correctly.

Take π as 3.14.

INFORMATION FOR CANDIDATES

You should give details of your method of solution when appropriate.

Unless stated, diagrams are not drawn to scale.

Scale drawing solutions will not be acceptable where you are asked to calculate.

The number of marks is given in brackets at the end of each question or part-question.

In question **9**, the assessment will take into account the quality of your linguistic and mathematical organisation, communication and accuracy in writing.

For Examiner's use only		
Question	Maximum Mark	Mark Awarded
1.	2	
2.	7	
3.	2	
4.	2	
5.	3	
6.	3	
7.	3	
8.	2	
9.	5	
10.	3	
11.	4	
12.	3	
13.	4	
14.	6	
15.	3	
16.	4	
17.	5	
18.	4	
Total	65	



NOV233300U10101

Formula List – Foundation Tier

Area of trapezium = $\frac{1}{2}(a + b)h$

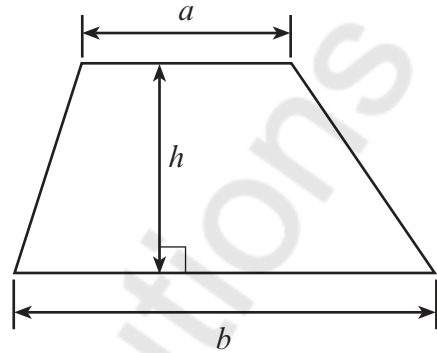

1. (a) Point O is the centre of the circle below.
Measure and write down the length of the diameter of the circle.
Write your answer in centimetres.

[1]

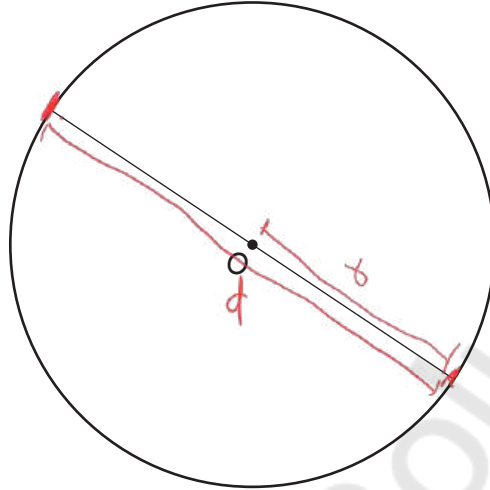

Length of diameter = cm

- (b) Measure and write down the size of angle x .

[1]

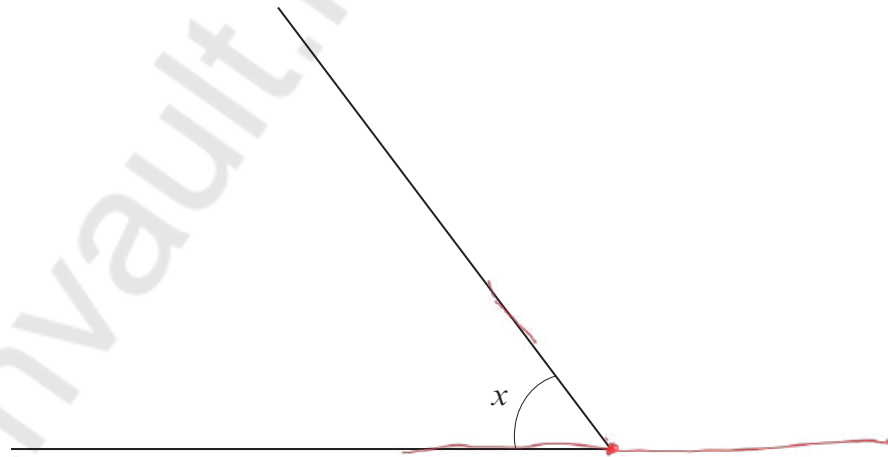

$x = \dots\dots\dots^\circ$

3300U101
03

2. (a) Arwyn doubles the number fifty-three thousand.
Write Arwyn's answer in figures. [2]

$$53,000 + 53,000 = 106,000$$

- (b) Write 3572 correct to the nearest 100. [1]

3600

3 5 7 2
T H T U

- (c) Calculate $6 + 4 \times 9$. [1]

$$6 + 4 \times 9 = 6 + 36$$

$$= 42$$

- (d) Estimate 103×9.8 . [2]

$$\begin{array}{r} 103 \\ \times 9.8 \\ \hline 824 \\ 927 \\ \hline 1009.4 \end{array}$$

- (e) Can 626 be divided exactly by 3?
You must show working to support your answer. [1]

Yes

No

$$6 + 2 + 6 = 14$$

Since 14 cannot be divided by 3 \therefore 626 cannot be divided by 3



3. Anna has 34 animals on her farm.
She has 10 goats, 20 sheep and 4 cows.
Anna chooses one of these 34 animals at random.

- (a) Describe the chance that Anna chooses a goat.
Circle the correct expression.

[1]

impossible **unlikely** **an even chance** **likely** **certain**

- (b) Describe the chance that Anna chooses a horse.
Circle the correct expression.

[1]

impossible **unlikely** **an even chance** **likely** **certain**



5. (a) Draw **all** the lines of symmetry on the shape below.

[2]

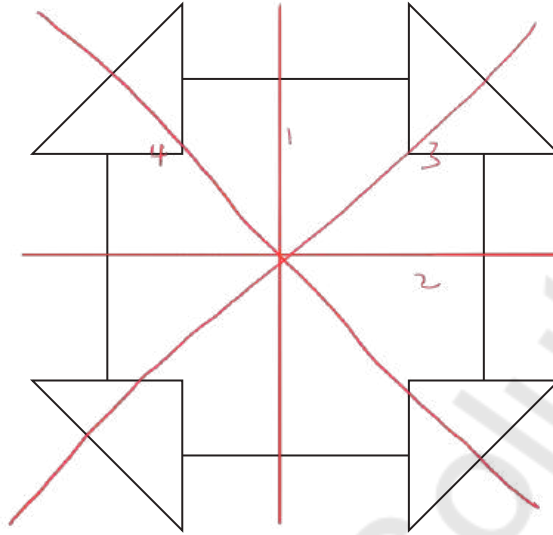

- (b) What is the order of rotational symmetry of the shape below?

[1]

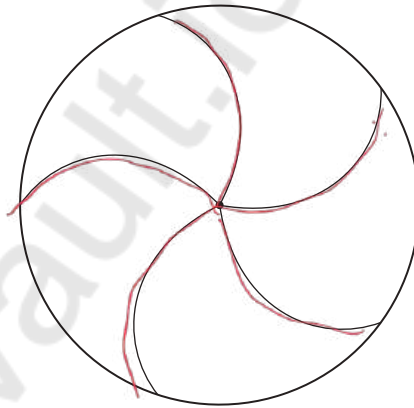

Order of rotational symmetry = 4



6. The points A , B and C are plotted on the grid below.

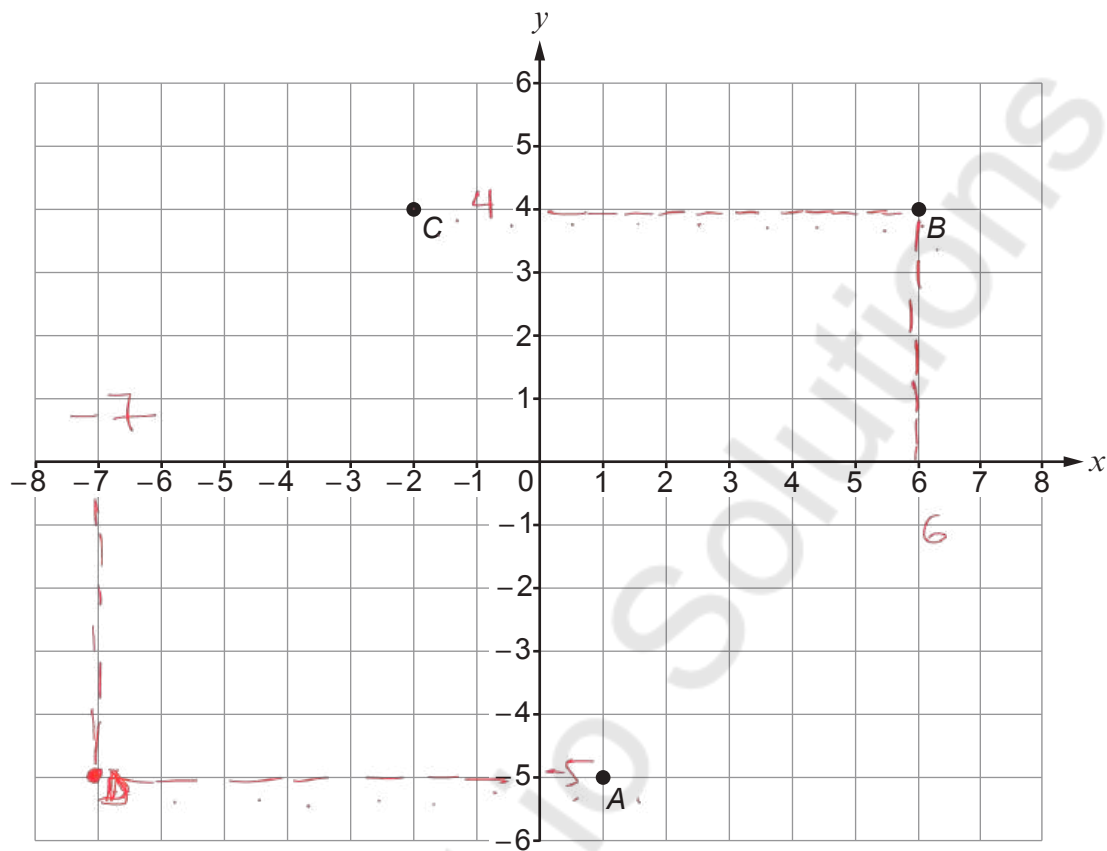

- (a) Write down the coordinates of point B $6, 4$ [1]
- (b) $ABCD$ is a parallelogram.
Both the x -coordinate and the y -coordinate of point D are **negative numbers**.
- (i) Plot the point D on the grid.
Label D clearly. [1]
- (ii) Write down the coordinates of point D $-7, -5$ [1]



7. (a) Solve the following equations.

(i) $p + 17 = 29$

[1]

$$p = 29 - 17$$

$$p = 12$$

(ii) $52 - n = 38$

[1]

$$-n = 38 - 52 = -14$$

$$n = 14$$

$$n = 14$$

(b) How many centimetres are there in 24.8 metres?

[1]

$$\frac{100 \text{ cm}}{x} = \frac{1 \text{ m}}{24.8 \text{ m}}$$

$$x = 100 \times 24.8 = 2480 \text{ cm}$$

8.

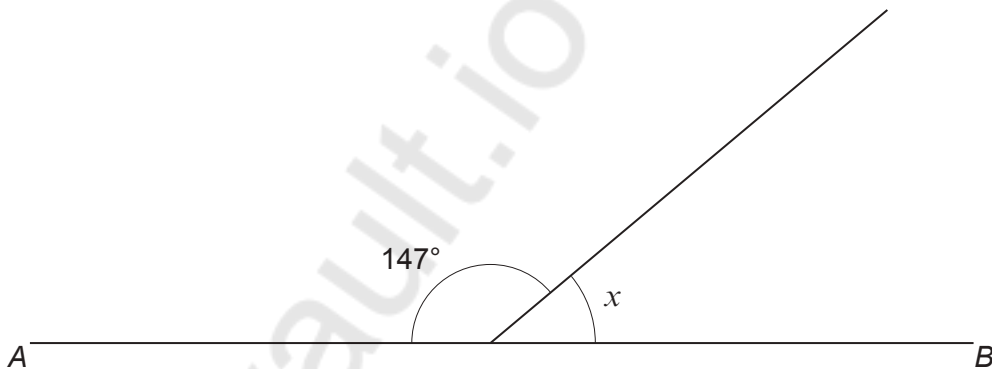

Diagram not drawn to scale

AB is a straight line.

Calculate the size of angle x .

[2]

$$x + 147^\circ = 180^\circ$$

$$x = 180^\circ - 147^\circ$$

$$x = 33^\circ$$

$$x = 33^\circ$$



9. In this question, you will be assessed on the quality of your organisation, communication and accuracy in writing.

The diagram below shows a shape made by joining two identical rectangles together. Each rectangle is 8 cm long and 5 cm wide. The length of AB is 6 cm.

Calculate the perimeter of the shape.
You must show all your working.

[3 + 2 OCW]

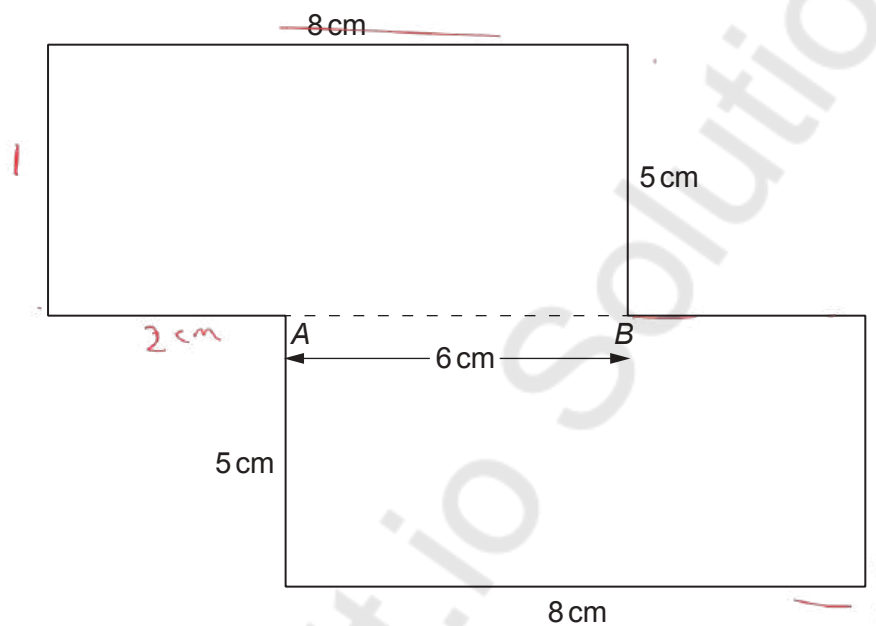

Diagram not drawn to scale

$$8 + 5 + 5 + 2 = 20 \text{ cm}$$

$$\text{For the whole shape} = 2 \times 20$$

$$= \underline{\underline{40 \text{ cm}}}$$



10. 200 pupils at a school were choosing lunch. Each pupil could choose peas, carrots or sweetcorn as their vegetable. Pupils could choose only **one** vegetable. The table below shows the probability that a randomly selected pupil chose peas, carrots or sweetcorn.

Vegetable	Peas	Carrots	Sweetcorn
Probability	0.5	0.2	0.3

On the grid below, draw a bar chart to show the number of pupils who chose each vegetable. [3]

Number of pupils

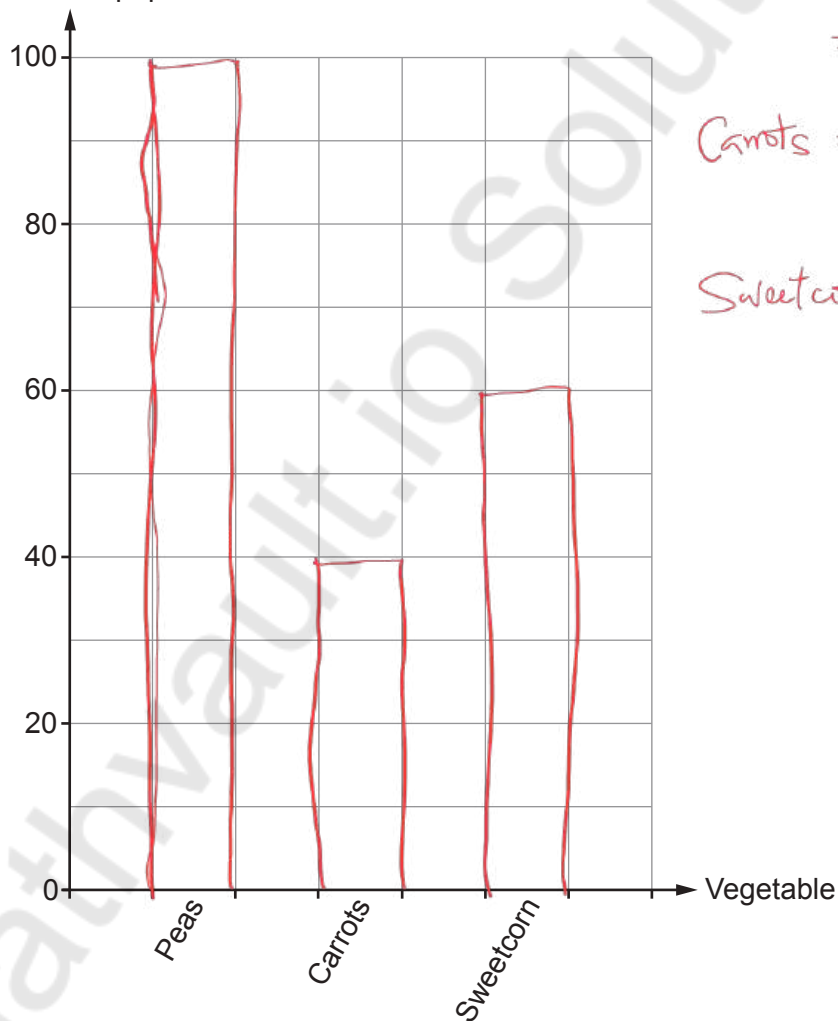

11. (a) Find the value of $5x+2y$ when $x=-4$ and $y=9$. [2]

$$\begin{aligned} 5x+2y &= 5(-4) + 2(9) \\ &= -20 + 18 \\ &= \underline{-2} \end{aligned}$$

- (b) Simplify the expression $5y+7m-3y-10m$. [2]

$$\begin{aligned} 5y+7m-3y-10m \\ 5y-3y-10m+7m \\ 2y-3m \end{aligned}$$

12. Write 0.41, $\frac{7}{20}$ and 45% in descending order. [3]

You must show all your working.

$$\frac{7 \times 5}{20 \times 5} = \frac{35}{100} = 0.35$$

$$45\% = \frac{45}{100} = 0.45$$

Then 0.41

$0.45 (45\%)$ 0.41 $0.35 \left(\frac{7}{20}\right)$
 Greatest value \longrightarrow Smallest value



13. Here is a net of a cuboid.

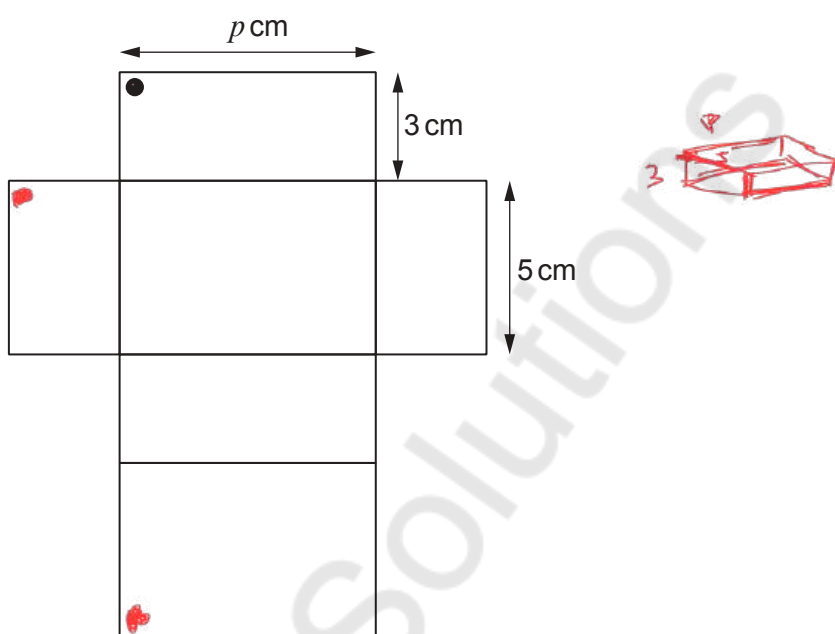

Diagram not drawn to scale

The net is folded to form a cuboid.

- (a) The corner marked with ● meets two other corners on the net.
Mark these two other corners with ●.

[2]

- (b) The volume of the cuboid is 90 cm^3 .
What is the value of p ?

[2]

$$\text{Vol} = L \times W \times h$$

$$90 \text{ cm}^3 = p \times 3 \times 5$$

$$90 = p \times 15 = 15p$$

$$p = \frac{90}{15} = 6 \text{ cm}$$



14. (a) Find $\frac{3}{7}$ of 9.17 km.

Give your answer in metres. [3]

$$9.17 \text{ km} \times 1000 = 9170 \text{ m}$$

$$\frac{3}{7} \times \overset{13}{\cancel{9170}}^{\cancel{10}} = 3 \times 1310$$

$$= 3930 \text{ m}$$

3930 metres

- (b) Express 25 minutes as a percentage of 2 hours 5 minutes. [3]

$$1 \text{ hr} = 60 \text{ mins}$$

$$2 \text{ hr} = 120 \text{ mins} + 5 \text{ mins} = 125 \text{ mins}$$

$$\frac{25 \text{ mins}}{125 \text{ mins}} \times 100 = 20 \text{ mins}$$



15. (a) The mean of four numbers is 9.
What is the total of the four numbers?

[1]

$$\text{Mean} = \frac{x}{4} \quad \text{hence } 9 \neq \frac{x}{4}$$

$$x = 9 \times 4 = \underline{36}$$

- (b) Find a set of four numbers such that:
- their mean is 9.
 - their mode is 11.

Write your four numbers in the boxes below.

[2]

$$a + b + c + d = 36$$

$$11 + 11 + c + d = 36$$

$$22 + c + d = 36$$

$$c + d = 36 - 22 = 14$$

$$\begin{aligned} c &= 6 \\ d &= 8 \end{aligned}$$

6

8

11

11



16. There are many socks in a drawer.
The socks are red, green, blue or pink.

- (a) A sock is chosen at random from the drawer.
Complete the table below.

[2]

Colour	Red	Green	Blue	Pink
Probability	0.3	0.1	0.35	0.25

$$0.3 + 0.1 + x + 0.25 = 1$$

$$0.4 + x + 0.25 = 1$$

$$x = 1 - 0.4 - 0.25$$

$$x = 1 - 0.65 = 0.35$$

- (b) In the drawer, there are 20 pink socks.
How many red socks are there in the drawer?

[2]

$$P_{\text{pink}} = \frac{20}{y} = 0.25$$

$$y = \frac{20}{0.25} = 80 \text{ socks}$$

$$\text{Red} = \frac{z}{80} = 0.3$$

$$z = 80 \times 0.3 = 24$$



17. The diagram below shows two shaded squares inside a larger square.

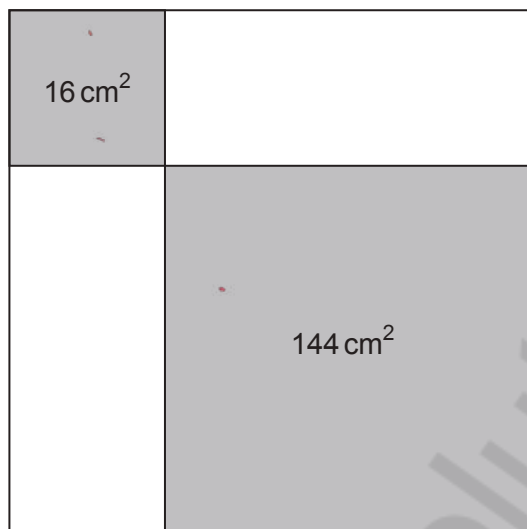

Diagram not drawn to scale

The diagram shows the area of each of the two shaded squares.

Calculate the **total** area of the two regions that have **not** been shaded.
You must show all your working.

[5]

$$\sqrt{\text{Area}} = l$$

$$\text{For the small shaded square} = \sqrt{16 \text{ cm}^2} = 4 \text{ cm}$$

$$\text{For the bigger shaded square} = \sqrt{144 \text{ cm}^2} = 12 \text{ cm}$$

$$\text{For the whole square} = 4 + 12 \text{ cm} = 16 \text{ cm}$$

$$\text{The area} = 16^2 = 256 \text{ cm}^2$$

$$\begin{aligned} & 256 \text{ cm}^2 - 144 \text{ cm}^2 - 16 \text{ cm}^2 \\ & = 256 \text{ cm}^2 - 160 \text{ cm}^2 \\ & = 96 \text{ cm}^2 \\ & \underline{\underline{\quad}} \end{aligned}$$



18. There are $7y - 2$ counters in Bag A.
There are $4y + 1$ counters in Bag B.



9 counters are added to Bag B.
There are now the same number of counters in each bag.

Form an equation in terms of y .
Solve the equation to find the value of y .
You must show all your working.

[4]

$$7y - 2 = 4y + 1 + 9$$

$$7y - 4y = 1 + 9 + 2$$

$$3y = 12$$

$$y = \frac{12}{3}$$

$$y = 4$$

END OF PAPER



BLANK PAGE

**PLEASE DO NOT WRITE
ON THIS PAGE**

Mathvaudio Solutions

