

Surname	Centre Number	Candidate Number
First name(s)		0



**GCSE**

3300U20-1



A23-3300U20-1

**WEDNESDAY, 15 NOVEMBER 2023 – MORNING**

**MATHEMATICS  
UNIT 2: CALCULATOR-ALLOWED  
FOUNDATION TIER**

1 hour 30 minutes

**ADDITIONAL MATERIALS**

A calculator will be required for this examination.  
A ruler, protractor and a pair of compasses may be required.

**INSTRUCTIONS TO CANDIDATES**

Use black ink or black ball-point pen. Do not use gel pen or correction fluid.  
You may use a pencil for graphs and diagrams only.  
Write your name, centre number and candidate number in the spaces at the top of this page.  
Answer **all** questions.  
Write your answers in the spaces provided in this booklet. If you run out of space, use the additional page(s) at the back of the booklet, taking care to number the questions correctly.  
Take  $\pi$  as 3.14 or use the  $\pi$  button on your calculator.

**INFORMATION FOR CANDIDATES**

You should give details of your method of solution when appropriate.  
Unless stated, diagrams are not drawn to scale.  
Scale drawing solutions will not be acceptable where you are asked to calculate.  
The number of marks is given in brackets at the end of each question or part-question.  
In question **6**, the assessment will take into account the quality of your linguistic and mathematical organisation, communication, and accuracy of writing.

For Examiner's use only		
Question	Maximum Mark	Mark Awarded
1.	2	
2.	2	
3.	2	
4.	3	
5.	6	
6.	5	
7.	2	
8.	7	
9.	3	
10.	2	
11.	2	
12.	3	
13.	2	
14.	4	
15.	2	
16.	3	
17.	4	
18.	2	
19.	4	
20.	5	
<b>Total</b>	<b>65</b>	



NOV233300U20101

## Formula List – Foundation Tier

Area of trapezium =  $\frac{1}{2}(a + b)h$

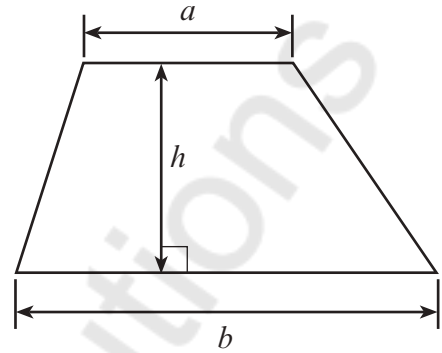

1. Write down the next term in each of the sequences below.

(a)  $53, 80, 107, 134, \dots$  [1]  
 $134 + 27 = 161$

(b)  $24, 72, 216, 648, \dots$  [1]  
 $648 \times 3 = 1944$

2. Write the special name for the line drawn on each of the circles below.

(a)

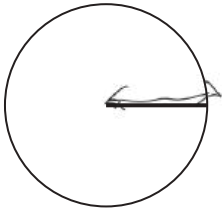

Radius

[1]

(b)

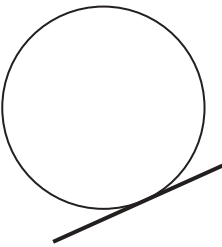

Tangent

[1]

3. (a) A fair coin is thrown once.  
On the probability scale below, mark with an arrow the probability of throwing a head. [1]

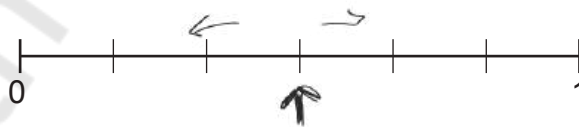

(b) A fair six-sided dice is thrown once.  
On the probability scale below, mark with an arrow the probability of throwing a 5. [1]

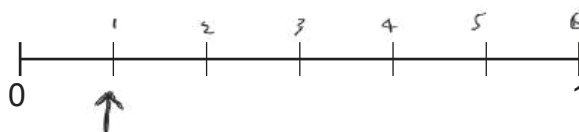

4. (a) (i) Which of these angles is the **largest acute** angle?  
Circle your answer. [1]

 $175^\circ$  $45^\circ$  $355^\circ$  $(85^\circ)$  $95^\circ$ 

- (ii) Which of these angles is the **smallest obtuse** angle?  
Circle your answer. [1]

 $(95^\circ)$  $75^\circ$  $275^\circ$  $105^\circ$  $185^\circ$ 

- (b) The line  $AB$  is shown below.

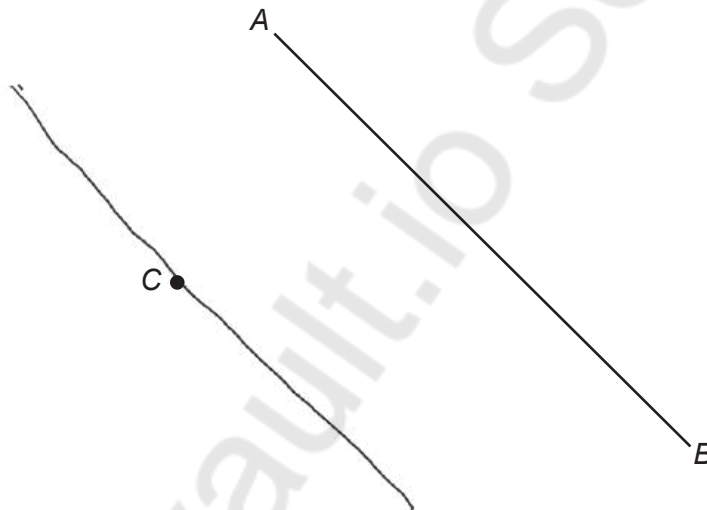

Draw a line, parallel to  $AB$ , through the point  $C$ .

[1]



5. (a) Arwel writes a list of six numbers:

3 3 4 4 5 6 ?

Arwel adds another number to his list.  
The mode of his seven numbers is an **odd** number.  
What number does Arwel add to his list?

[1]

3, 3, (3), 4, 4, 5, 6

Arwel added 3

The number that Arwel adds to his list is 3

- (b) Ffion writes a list of seven numbers:

3 8 4 1 2 8 9

What is the median of Ffion's seven numbers?

[2]

1, 2, 3, (4), 8, 8, 9

The median of Ffion's seven numbers is 4

- (c) Marc writes down two numbers:

2 7 ~~8~~

Marc adds another number to his list.  
The mean of his three numbers is 5.

What number does Marc add to his list?  
You must show all your working.

[3]

Mean =  $\frac{\text{total no of values}}{\text{no of values}}$ 

$$5 = \frac{2+7+x}{3} = \frac{9+x}{3}$$

$$5 \times \frac{9+x}{3}$$

$$x+9 = 5 \times 3 = 15$$

$$x = 15 - 9 = 6$$

The number that Marc adds to his list is 6



6. In this question, you will be assessed on the quality of your organisation, communication and accuracy in writing.

Dylan and Angharad make cuboids and cubes out of centimetre cubes.

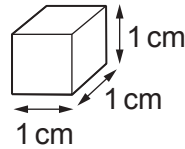

Dylan makes the cuboid below.

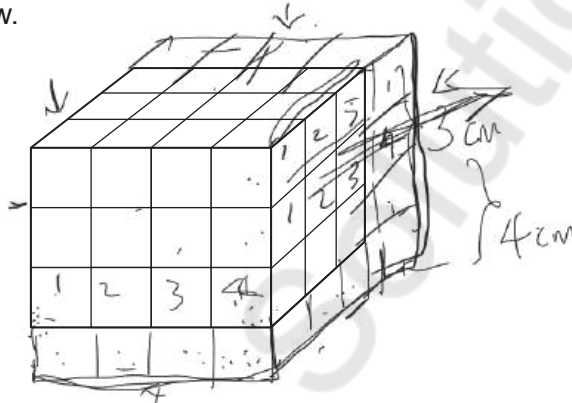

Angharad makes a cube with edges of length 4 cm.

How many **more** centimetre cubes does Angharad use than Dylan?  
You must show all your working.

[3 + 2 OCW]

Angharad must add a corner / layer to make a cube  
with edges of length 4cm

For the length =  $4 \times 4$  cubes = 16 cubes

For the width =  $3 \times 4$  cubes = 12 cubes

In total, he added  $16 + 12$  cubes  
= 28 cubes



7. Write 27 minutes and 11 seconds in **seconds**. [2]

~~60 secs~~ ~~x~~ ~~27 times~~ ~~1 min~~ ;  $x = 27 \times 60 = 1620 \text{ secs}$   
 Add the 11 secs ;  $\therefore 1620 \text{ secs} + 11 \text{ seconds}$   
 $= 1631 \text{ seconds}$   
 27 minutes and 11 seconds = 1631 seconds

8. (a) Find the value of  $\frac{144 \times 30^2}{18}$ . [2]

Write your answer correct to the nearest thousand.

$\frac{144 \times 30^2}{18} = \frac{144 \times 900}{18} = \frac{129,600}{18} = 7200$   
 To the nearest thousand ;  $7200 \approx 7000$

- (b) Calculate 4% of £250. [2]

$250 \times \frac{4}{100} = \frac{100}{10} = \text{£}10$

- (c) Laura thinks of a number. [3]

$\frac{1}{5}$  of her number is 14.

What is 50% of Laura's number?

Let's say Laura's no is  $x$   
 So  $\frac{1}{5} \times x = 14$  ;  $\frac{x}{5} = 14$   
 $x = 14 \times 5 = 70$   
 $50\% \text{ of } x = \frac{50}{100} \times 70$   
 $50\% \text{ of } x = 35$

50% of Laura's number is 35



9. Write an expression, in terms of  $x$ , to represent each of the following.

(a) 5 more than  $x$

[1]

$$x + 5$$

(b)  $x$  less than 3

[1]

$$3 - x$$

(c) half of  $x$

[1]

$$\frac{1}{2}x$$

10. (a) What is 2 litres approximately equal to?  
Circle your answer.

[1]

2 pints

3 pints

3.5 pints

4.4 pints

200 pints

~~$$1 \text{ litre} \leftarrow 1.76 \text{ pints}$$~~

$$2 \times 1.76 = x$$

~~$$2 \text{ litres} \leftarrow x$$~~

$$x = 3.52 \text{ pints}$$

(b) What is 32 km approximately equal to?  
Circle your answer.

[1]

16 miles

20 miles

32 miles

51 miles

64 miles

~~$$1 \text{ mile} \leftarrow 1.6 \text{ km}$$~~

$$1.6x = 32 \text{ km} \quad x = 20 \text{ miles}$$

~~$$x \leftarrow 32 \text{ km}$$~~

$$\frac{1.6x}{1.6} = \frac{32 \text{ km}}{1.6}$$



11. (a) A pencil case contains some pens.  
One pen is chosen at random.  
The probability that the chosen pen is blue is 45%.  
What is the probability that the chosen pen is **not blue**? [1]

The probability should add up to 100

$$100 - 45\% = \underline{55\%}$$

- (b) Dewi throws a fair six-sided dice.  
What is the probability that Dewi throws a prime number?  
Circle your answer. [1]

1 (2) (3) 4 (5) 6

$$\frac{1}{6}$$

$$\frac{1}{2}$$

$$\frac{5}{6}$$

$$\frac{1}{3}$$

$$\frac{2}{3}$$

3 prime no. out of 6  
so  $\frac{3}{6} = \frac{1}{2}$

12. (a) Solve the equation  $8a + 3 \cdot 5 = 27 \cdot 5$ . [2]

$$8a + 3 \cdot 5 = 27 \cdot 5$$

$$8a = 27 \cdot 5 - 3 \cdot 5 = 24$$

$$a = \frac{24}{8} = \underline{3}$$

- (b) A number machine is shown below.

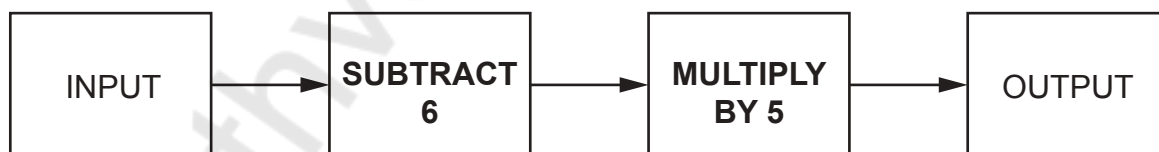

Calculate the OUTPUT when the INPUT is 1.5. [1]

$$(1.5 - 6) \times 5 = x$$

$$-4.5 \times 5$$

$$= \underline{\underline{-22.5}}$$



13. A **decimal** number is written on a card.

You have three clues to help you work out the number on the card.

Clue 1: The number is between 5 and 12 inclusive.

Clue 2: The number is a multiple of 2.3.

Clue 3: The square of the number is greater than 50 but less than 120.

What is the decimal number on the card?

[2]

Clue 1:  $\frac{1}{5}$  5 6 7 8 9 10 11 12

Clue 2:  $2.3 \times 1 = 2.3$   
 $2.3 \times 2 = 4.6$  } too small

$$2.3 \times 3 = 6.9$$

$$2.3 \times 4 = 9.2$$

$$2.3 \times 5 = 11.5$$

$$2.3 \times 6 = 13.8 \text{ — too big}$$

So just 6.9, 9.2 & 11.5

Clue 3:  $6.9^2 = 47.61$  X

$$9.2^2 = 84.64$$
 ✓

$$11.5^2 = 132.25$$
 X

The decimal number on the card = 9.2



14. (a) Evaluate  $\frac{18 \cdot 4^3 + 8 \cdot 7^4}{7 \cdot 3^2}$ .

Give your answer correct to the nearest 10. [2]

$$\frac{18 \cdot 4^3 + 8 \cdot 7^4}{7 \cdot 3^2} = \frac{6229.5 + 879}{53.29}$$

$$= \frac{6238.29}{53.29} = \overset{\downarrow}{117} \approx \underline{120} \text{ (to the nearest tens)}$$

(b) Evaluate  $\sqrt{1456} \times 3.7$ .

Give your answer correct to 1 decimal place. [2]

$$\sqrt{1456} \times 3.7$$

$$= 38.16 \times 3.7$$

$$= 141.192$$

$$\approx 141.2 \text{ (to 1 decimal place)}$$

15. Kamal worked for a total of 36 hours in one week.

On Monday, Tuesday and Wednesday, he worked the same number of hours each day.

On both Thursday and Friday, he worked for half as long as he did on any of the first three days.

He did not work on Saturday or Sunday.

How many hours did Kamal work for on Friday? [2]

$$x + x + x + \frac{1}{2}x + \frac{1}{2}x = 36 \text{ hours}$$

$$3x + 1x = 36 \text{ hrs}$$

$$4x = 36 \text{ hrs}$$

$$x = \frac{36 \text{ hrs}}{4} = 9 \text{ hrs}$$

On Friday, he worked for  $\frac{1}{2}x$ ;  $\frac{1}{2} \times 9$   
 $= 4.5 \text{ hrs}$

Kamal worked for 4.5 hours on Friday



16. (a) Translate the triangle 6 squares to the left and 2 squares down.

[1]

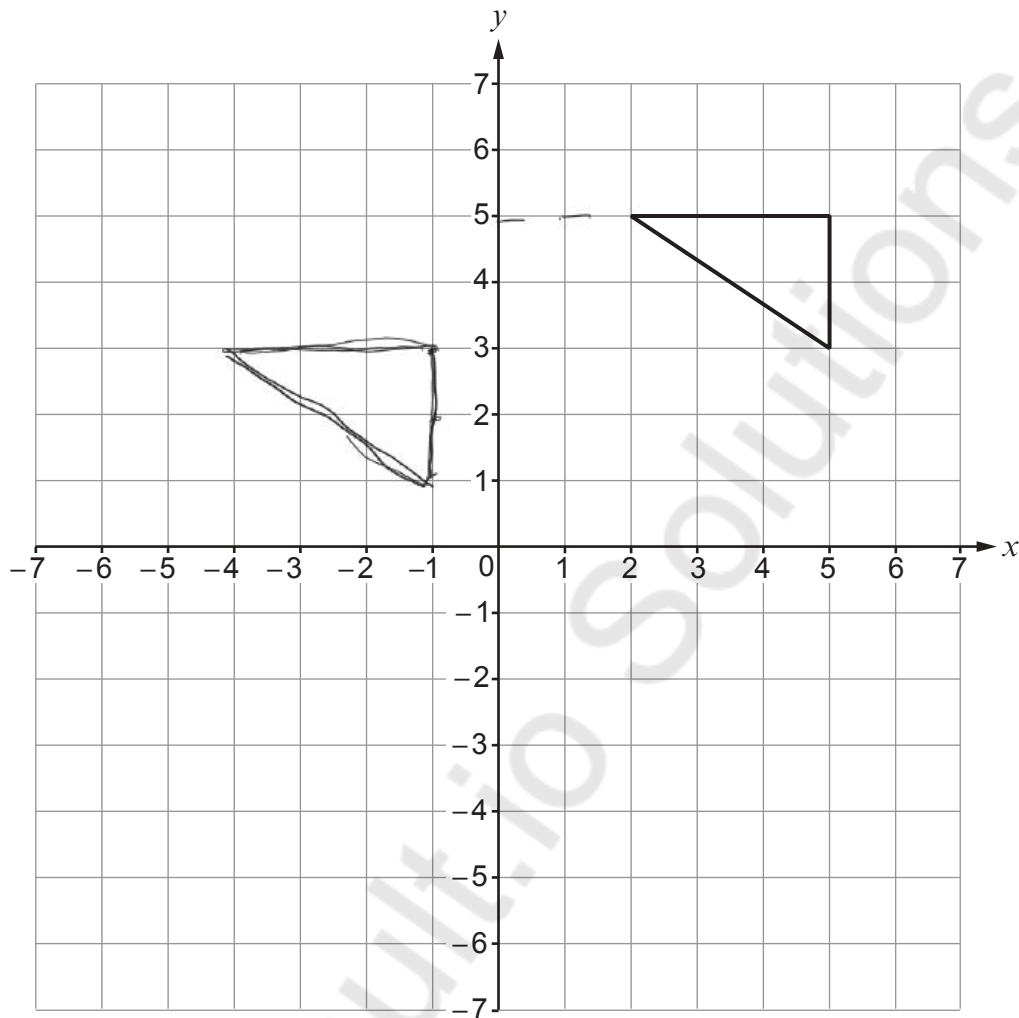

(b) Reflect the triangle in the line  $y = 1$ .

[2]

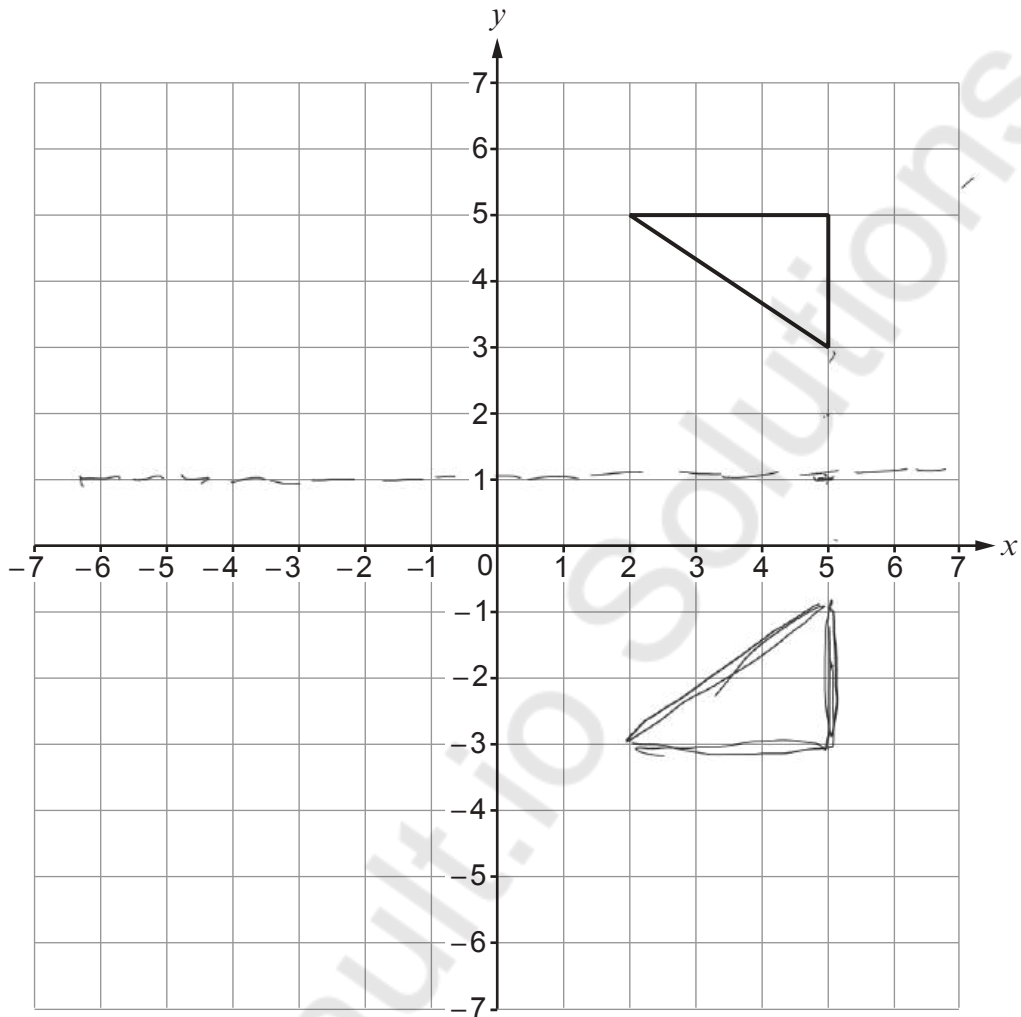

17. The shape below has a total length of 35 cm.  
The shape is cut into three parts, A, B and C.

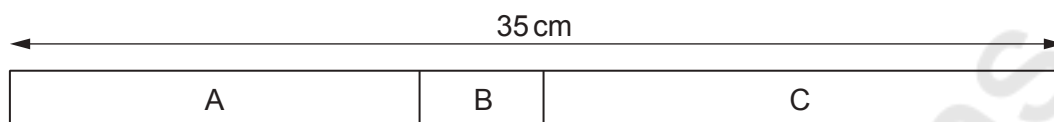

Diagram not drawn to scale

The length of A is  $\frac{2}{5}$  of the total length of the shape.

The lengths of B and C are in the ratio 1 : 6.

Find the length of **each** part of the shape.

You must show all your working.

[4]

$$\text{length of A} = \frac{2}{5} \times 35 = 14 \text{ cm}$$

$$A + B + C = 35 \text{ cm}$$

$$14 + B + C = 35 \text{ cm}$$

$$B + C = 35 - 14 = 21 \text{ cm}$$

$$B : C = 21$$

$$C \text{ — } ?$$

$$1 + 6 = 21$$

$$6 \text{ — } x$$

$$x = \frac{21 \times 6}{1 + 6} = \frac{126}{7} = 18 \text{ cm}$$

So C is 18 cm

$$\text{Since } B + C = 21 \text{ cm}$$

$$B = 21 - 18$$

$$B = 3 \text{ cm}$$

$$A = 14 \text{ cm}, \quad B = 3 \text{ cm}, \quad C = 18 \text{ cm}$$



18. The diagram below shows the graph of the straight line  $y = 2x + 4$  for values of  $x$  from  $-3$  to  $3$ .

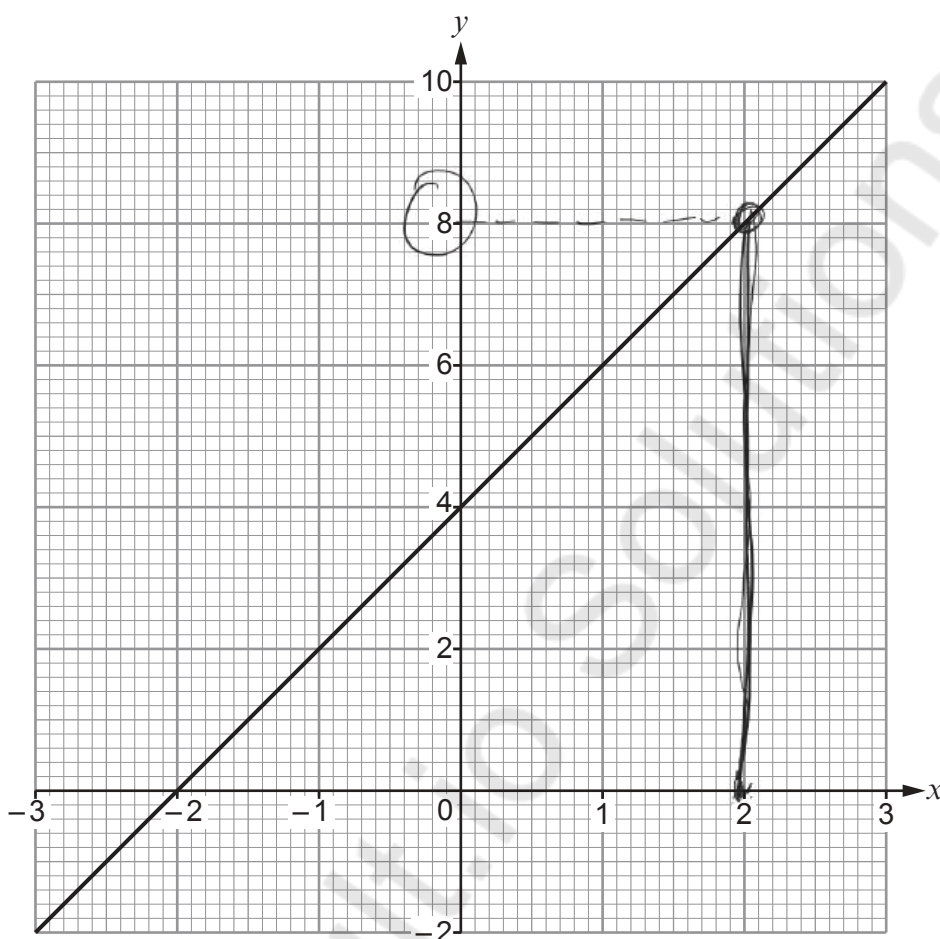

(a) Draw the line  $x = 2$  on the graph paper. [1]

(b) Write down the coordinates of the point where the lines  $y = 2x + 4$  and  $x = 2$  intersect. [1]

$$y = 2(2) + 4 = 4 + 4 = 8$$

The coordinates of the point where  $y = 2x + 4$  and  $x = 2$  intersect = (2, 8)



19. The table below shows the percentages of different amounts.  
Three values have been calculated.

Complete the table.

[4]

		Amount	
		£36	£ 92
Percentage	10 %	£3.60	£9.20
	13.5%	£ 4.86	£12.42

$$\frac{10}{100} \times 36 = 3.6$$

$$\frac{10}{100} \times x = 9.2$$

$$\frac{x}{10} \times 9.2 = 9.2 \quad x = 10 \times 9.2 = 92$$

$$\frac{13.5}{100} \times 36 = 4.86$$



20. The diagram shows two circles that fit in a rectangle.  
 The centre of the small circle is directly below the centre of the large circle.  
 The diameter of the small circle is 8 cm.  
 The **radius** of the large circle is 2 cm greater than the **radius** of the small circle.

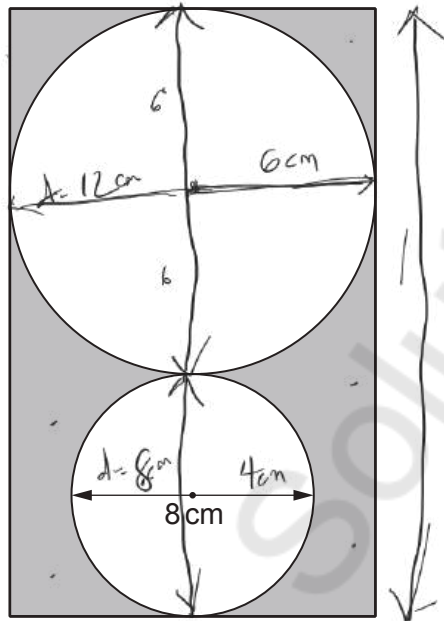

Diagram not drawn to scale

Calculate the total area of the shaded parts of the rectangle.

[5]

$$\text{Area of a circle} = \pi r^2$$

$$\text{For the big circle} = 3.14 \times 6^2 = 113.04$$

$$\text{For the small circle} = 3.14 \times 4^2 = 50.24$$

$$\text{Add the areas of the circle} = 113.04 + 50.24 = 163.28 \text{ cm}^2$$

$$\text{The area of the rectangle} = \text{length} \times \text{width}$$

$$20 \text{ cm} \times 12 \text{ cm}$$

$$= 240 \text{ cm}^2$$

$$\text{The total area of the shaded portion} = 240 \text{ cm}^2 - 163.28 \text{ cm}^2$$

$$= 76.72 \text{ cm}^2$$

END OF PAPER



Question number	Additional page, if required. Write the question number(s) in the left-hand margin.
	<p>Mathsvault.io Solutions</p>

Examiner only



**BLANK PAGE**

**PLEASE DO NOT WRITE  
ON THIS PAGE**

Mathvaudio Solutions



**BLANK PAGE**

**PLEASE DO NOT WRITE  
ON THIS PAGE**

Mathvaudio Solutions

